



Glennair®



Series 79 Micro-Crimp Connectors and Accessories

*The High-Performance Rectangular with
Advanced EMC and Environmental Performance*

United States ■ United Kingdom ■ Germany ■ France ■ Nordic ■ Italy ■ Spain ■ Japan

Second Edition • June 2011

SERIES 79

MICRO-CRIMP

ULTRAMINIATURE • SHIELDED • ENVIRONMENTAL



Meet the newest member of Glenair's rectangular connector family, the Series 79 Micro-Crimp. The ultraminiature Micro-Crimp connector features crimp, rear-release size #23 contacts on .075 inch (1.9 mm) spacing, as well as size #12 and #16 power, coaxial and fiber optic contacts. Available in 31 hybrid insert arrangements, the Micro-Crimp offers broad versatility for data and power transmission. Today's defense/aerospace systems require advanced levels of environmental protection, electromagnetic shielding and size/weight reduction. The Series 79 was developed to meet these needs. Panel mounted connectors feature conductive sealing gaskets. Right angle printed circuit board connectors have an EMI shroud to prevent electromagnetic interference. Wire sealing grommets and interfacial seals protect circuits from moisture and contamination. Series 79 plugs are also available with auxiliary EMI springs for advanced EMC performance.



Series 79 Micro-Crimp Connectors and Accessories Table of Contents



Series 79
Micro-Crimp
Introduction

Introduction to the
Series 79 Micro-Crimp Connector

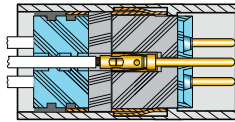

Product Features,
Selection Guide and
Technology Showcase

A

Signal, Power and Coaxial
Contacts and Crimp Tools



Contacts.....B-2 to B-7
Tools.....B-8 to B-11

B

General Information
and Reference

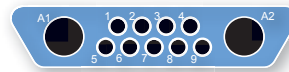

Insert Arrangements.....C-1
Materials and Specs.....C-5
Plating Options.....C-9
Space Grade Versions...C-10
Panel Cutouts.....C-14

C

Crimp Terminated
Cable Connectors



790-024P and 790-025S

D

Crimp Terminated
Panel Mount Connectors



790-026P, 790-027S,
790-050P, 790-049S

E

Straight PCB Panel Mount
and Free-Standing Connectors



790-028P, 790-043P,
790-029S, 790-044S,

F

Right Angle PCB Panel Mount
and Free-Standing Connectors



790-036P, 790-041P,
790-037S, 790-042S

G

Backshells and Accessories,
EMI Adapters and Protective Covers



799-015, 799-016,
799-011, 799-018,
799-019

H

Part Number Index



INDEX

Dimensions in Inches (millimeters) are subject to change without notice.



Introduction to the Series 79 Micro-Crimp Connector

The Micro-D Connector with Crimp Contacts

MICRO-CRIMP™

Meet the newest member of Glenair's Micro-D family, the Series 79 Micro-Crimp. The

Micro-Crimp connector features crimp, rear-release size #23 contacts on .075 inch (1.9 mm) spacing, as well as size #12 and #16 power and coaxial crimp contacts in a range of hybrid layouts. Available in 31 insert arrangements, the Micro-Crimp provides a wide selection of arrangements for data and power transmission.

Today's defense/aerospace systems require advanced levels of environmental protection, electromagnetic shielding and size/weight reduction. The Series 79 was developed to meet these needs. Panel mounted connectors feature conductive sealing gaskets. Right angle printed circuit board connectors have an EMI shroud to prevent electromagnetic interference. Wire sealing grommets and interfacial seals protect circuits from moisture and contamination. Series 79 plugs are available with auxiliary EMI springs for superior EMC performance.



Cable Plug With Socket Contacts and EMI Spring

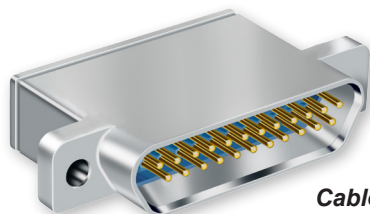

Cable Receptacle With Pin Contacts



Panel Mount Right Angle PCB Plug with EMI Shroud and EMI Spring

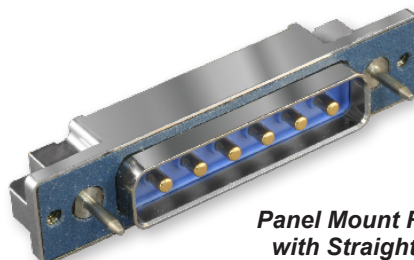

Panel Mount Receptacle with Straight PC Tails

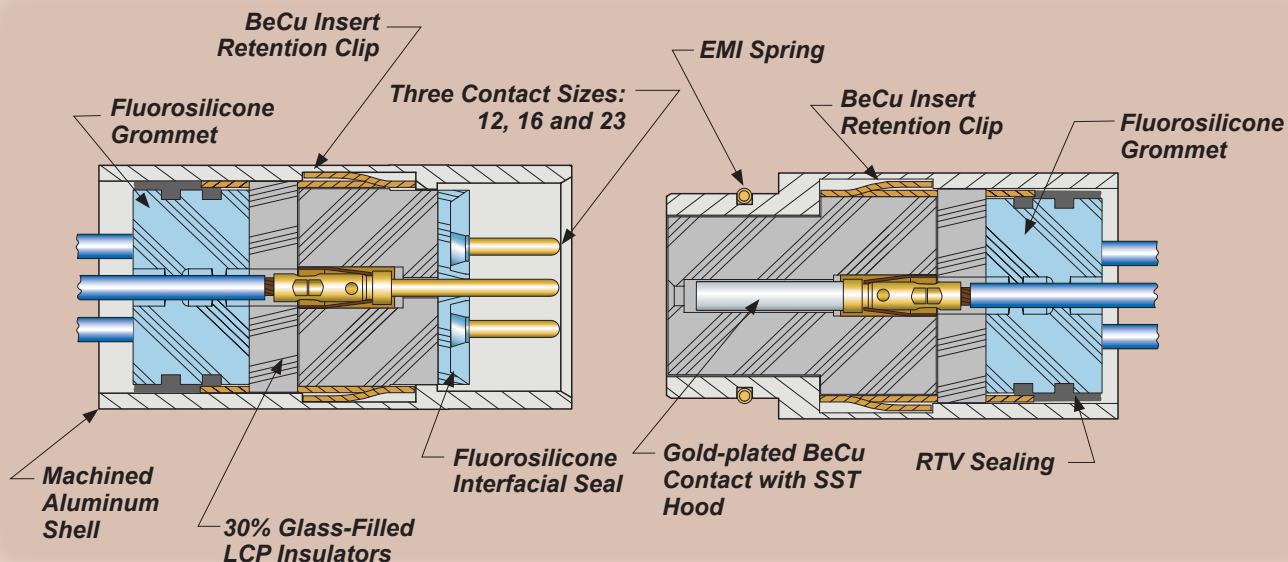

Dimensions in Inches (millimeters) are subject to change without notice.

Series 79 Micro-Crimp Connector Selection Guide

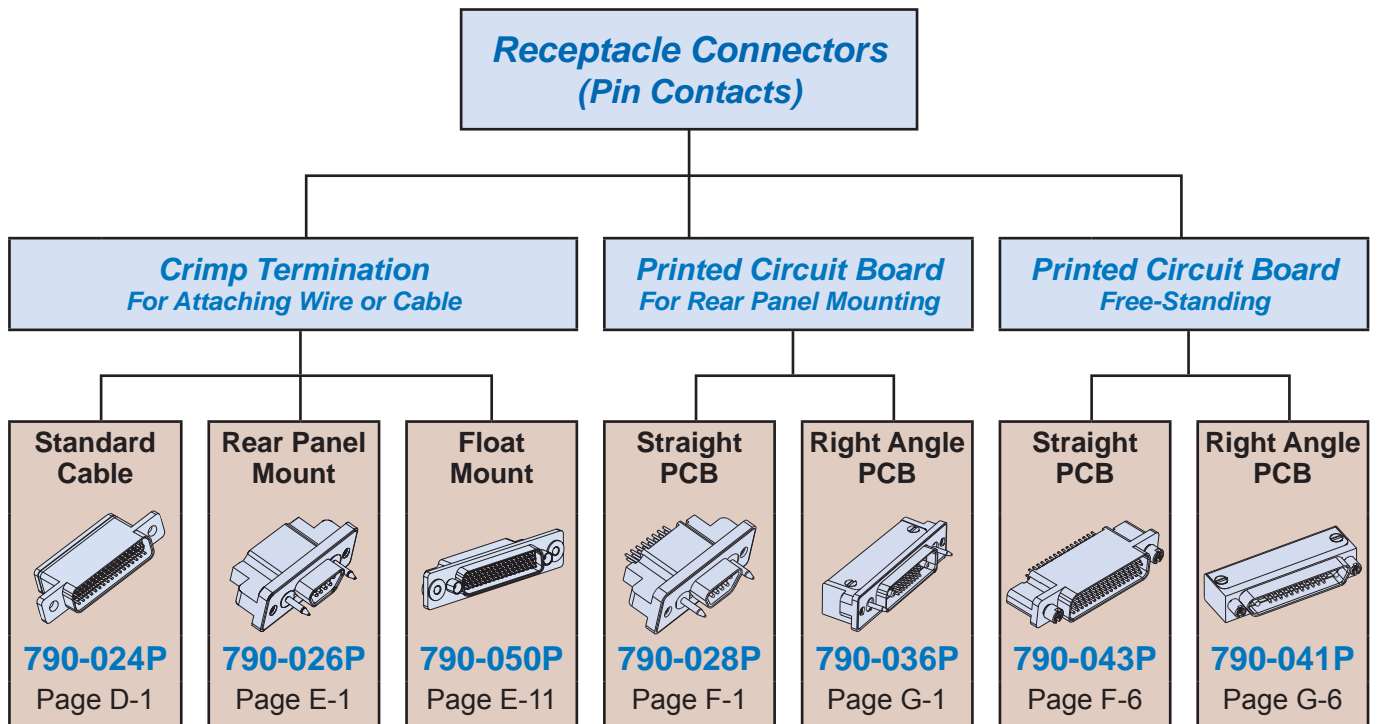
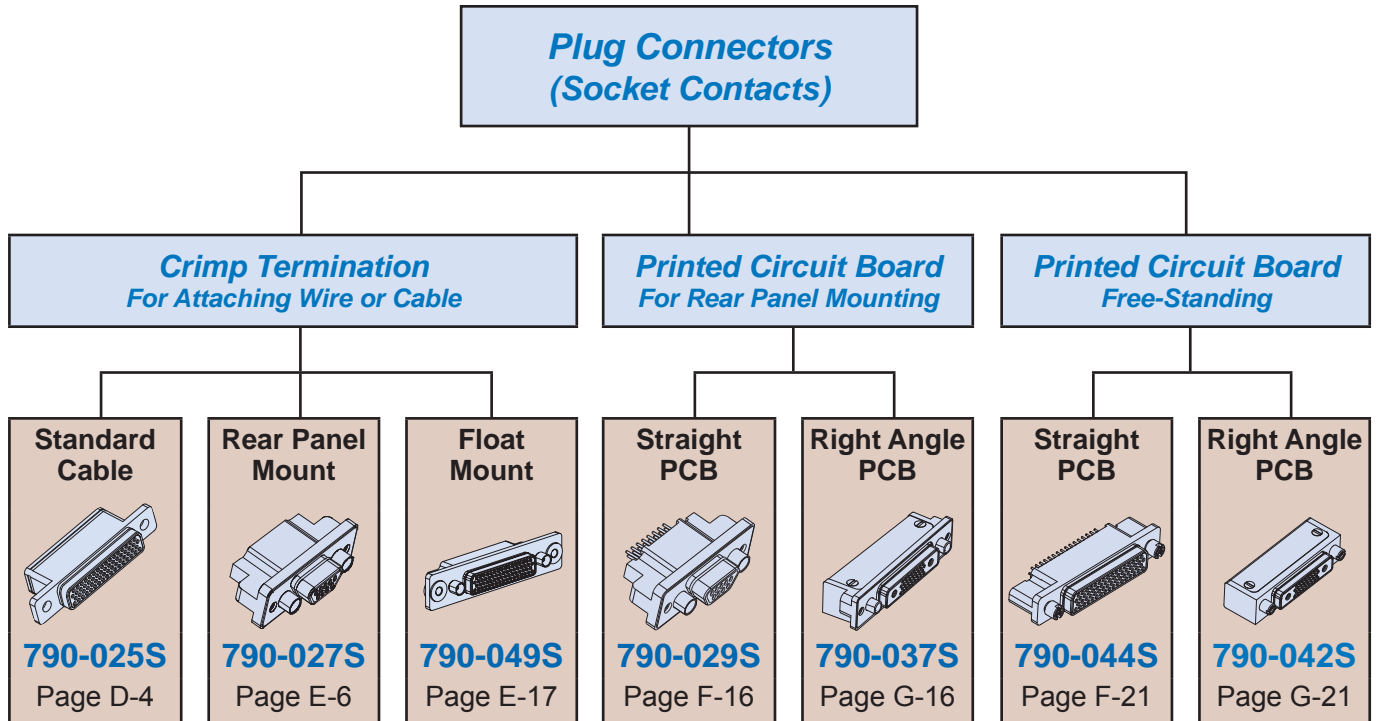

Dimensions in Inches (millimeters) are subject to change without notice.



Series 79 Micro-Crimp Connector Technology Showcase

A

MICRO-CRIMP™

Technology Showcase

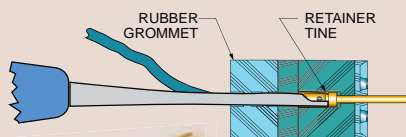

Rear-Release Crimp Contacts

Series 79 Size #23 contacts conform to the AS39029 requirements, but are not covered by a slash sheet. Size #16 and size #12 contacts are standard "QPL" contacts used in MIL-DTL-38999 connectors.



Integrated EMI Shroud

Right angle printed circuit board connectors have an EMI shroud to prevent electromagnetic interference.



Gold-plated M39029 size #12 and #16 contacts for high current capacity.

Snap-In COAX & Power Pins

Size #12 contacts accept #12-14 AWG wire. Size 12 and 16 cavities also accept coaxial contacts purchased separately. These crimp contacts are plated with 50 microinches gold over nickel underplating.

Integrated Ground Spring

Series 79 plugs are available with auxiliary EMI springs for superior EMC performance.



Shielded Panel Mount Connectors

Avoid EMI problems "inside-the-box" with optional EMI adapters. These adapters attach to standard panel mount crimp-type versions.



Panel mount connector with optional EMI adapter.



#16 Fiber Optic Contacts

Size #16 fiber optic termini are compatible with all Series 79 Micro-Crimp connectors with size #16 cavities. These snap-in, rear-release termini feature precision ceramic ferrules and sleeves for accurate fiber alignment. Typical insertion loss 0.5 dB. Fits 50/125 and 62.5/125 multi mode and 9/125 single mode fiber. Stainless steel bodies and springs.



Low profile EMI adapters for cable braid termination with Glenair's BAND-IT® straps.

EMI Backshell Adapters

These two-piece adapters fit into a groove on Micro-Crimp cable connectors. Attach to connector with screws (provided). Elliptical banding platform provides ample room for large wire bundles.



Jackpost Hardware Options

A complete range of jacking hardware is available including captivated, low-profile and extended versions.

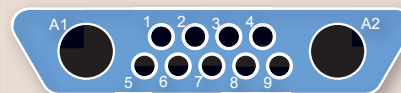

Over Thirty Layouts

Twelve different shell sizes are offered with from 5 to 102 contacts. #23, #16 and #12 AWG cavities accept signal, power, shielded and fiber optic contacts. Hybrid layouts support a wide range of common requirements.

Dimensions in Inches (millimeters) are subject to change without notice.

MICRO-CRIMP™

Technology Showcase



Series 79 with size #12 power pins for up to 23 amp current capacity.

Micro-Crimp Combo Layouts

Thirty-one contact arrangements are available with size #23 contacts for signal and data, size #16 contacts for up to 13 amps power, or size #12 contacts for up to 23 amp capacity. All 31 arrangements are available with crimp pins or with printed circuit tails.

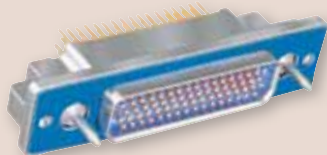

790-028PH-66 with stainless steel guide pins for blind mate applications.

Guide Pins for Blind Mating

Series 79 panel connectors can be configured with guiding hardware for module-to-chassis applications.



Shield Termination System

Glenair Band-Master Advanced Termination System delivers turnkey shield termination tools, bands and calibration services.

Pneumatic Contacts

Snap these “gas” pitot tube contacts snap into any size #12 contact cavity and are designed for air speed sensor applications. Attach standard tubing to the contact. These stainless steel contacts are removable.



Size #12 pneumatic contacts withstand up to 100 PSI air pressure for pitot tube applications.

Float Mount Connectors

790-050P connectors are equipped with rear-panel float mounting assemblies to provide additional mounting lee-way in rack and panel applications.

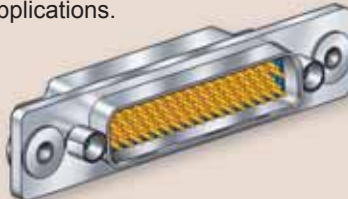

Float Mount connectors feature machined aluminum shells and wire grommets for environmental protection.

Conductive Panel Gaskets

Panel mount connectors are supplied with conductive fluorosilicone gaskets for sealing to bulkheads. These gaskets provide an easy way to assure a watertight installation.

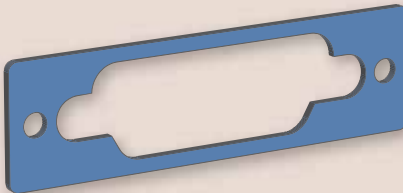

Right angle PCB connectors for thru-hole termination

Right Angle PCB Header

Available in panel mount (shown) or free-standing versions, these connectors feature an EMI shroud and threaded board mounting holes.

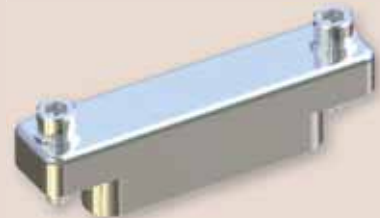

Protective Covers

Machined aluminum covers prevent ingress of water and contamination. Plug covers provide metal-to-metal bottoming for EMI protection. Receptacle covers feature conductive fluorosilicone gaskets. For attachment, Choose small diameter eye fittings for panel attachment. Larger rings fit over cable jackets. Split rings can be installed on fully assembled cables.

Watertight EMI gaskets are supplied with all panel mount Micro-Crimp connectors.

Dimensions in Inches (millimeters) are subject to change without notice.

SERIES 79

MICRO-CRIMP

CONTACTS • ASSEMBLY TOOLS • BAND-MASTER™ ATS

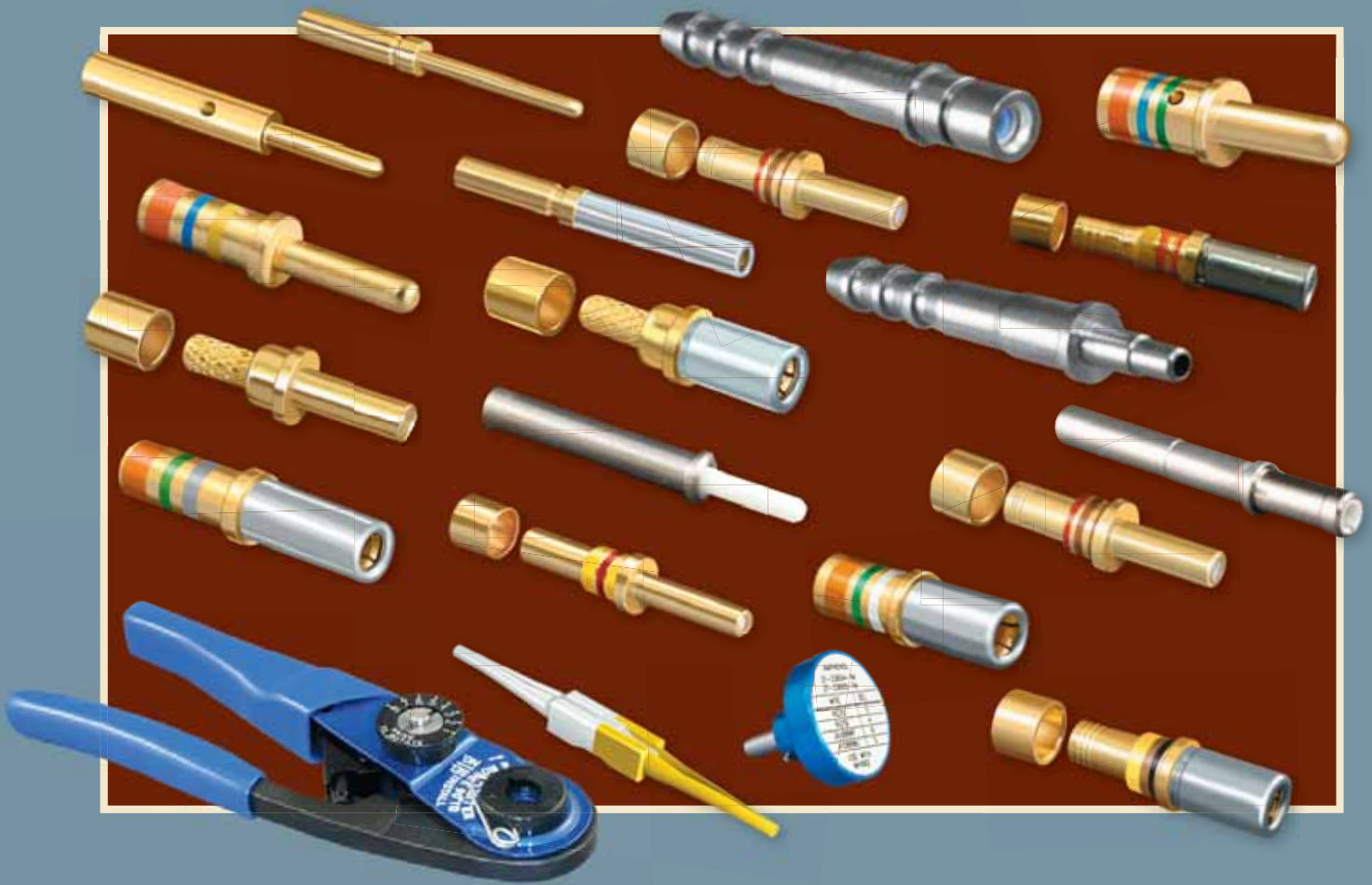

Series 79 Micro-Crimp signal, power and coaxial contacts are crimped to wire using mil spec crimpers. The Micro-Crimp connector features crimp, rear-release size #23 contacts on .075 inch (1.9 mm) spacing, as well as size #12 and #16 power, coaxial, fiber optic contacts in a range of hybrid layouts. Available in 31 insert arrangements, the Micro-Crimp provides a wide selection of arrangements for data and power transmission. Military Specification MIL-DTL-22520 provides the aerospace/defense industry with a common set of rugged, reliable hand crimp tools. This specification controls the voltage drop and tensile strength of crimp terminations. The Series 79 Micro-Crimp family of products is well-supported with a complete range of contacts, tools and assembly instructions for turnkey assembly and use.



Series 79 Micro-Crimp Contacts and Tools



Signal and Power Contacts
B-2



Coaxial Contacts
B-5



Pneumatic Contacts
B-7



Crimp Tools
B-8



Insertion/Extraction Tools
B-10



Band-Master™ Tool and Bands
B-11

About Mil Spec Contacts For Series 79 Micro-Crimp Connectors

Aerospace Standard AS39029 (SAE) defines the design, dimensions and performance of contacts used in aerospace grade electrical connectors. The "general specification" covers a variety of contacts including thermocouple, hermetic, coaxial and triaxial types.

The "slash sheets" contain dimensions and other information for specific types of contacts. For example, pin contacts used in MIL-DTL-38999 connectors are specified

in AS39029/58. Each contact is assigned a Basic Identification Number (BIN), a non-significant three digit code corresponding to the color code on the contacts. A Qualified Products List (QPL) identifies those manufacturers whose products have been verified to meet all requirements. Series 79 Size #23 contacts conform to the AS39029 requirements, but are not covered by a slash sheet. Size #16 and size #12 contacts are standard "QPL" contacts used in MIL-DTL-38999 connectors.

Coaxial contacts are covered by AS39029. These contacts are not recommended for high frequency applications. Note 6.1.2 states "Type D contacts are coaxial contacts... to shield the circuit from unwanted interference (RFI and EMI). These contacts are not impedance (matched) and, therefore, are not recommended for RF use." Matched impedance 50 ohm coaxial contacts are available but are not covered by the AS39029 specification.

About Mil Spec Crimp Tools

Series 79 Micro-Crimp signal, power and coaxial contacts are crimped to wire using mil spec crimpers. Military Specification MIL-DTL-22520 provides the aerospace/defense industry with a common set of rugged, reliable hand crimp tools. This specification controls the voltage drop and tensile strength of crimp terminations.

Before ordering, check to see if you might already have these tools! We have listed the military part number and the Daniels part number. Daniels Manufacturing Corporation is the leading manufacturer of these tools. The size 23 positioner part number 809-005 is not a standard tool. Chances are, you will need this positioner

Calibration: gage pins are available for checking crimp tool calibration. Tools should be checked periodically. If a tool needs calibration, the mil spec requires calibration to be performed by the manufacturer or a certified ANSI-Z540.1 agency. Gauging and calibration information is supplied in the box with the tool.

Dimensions in Inches (millimeters) are subject to change without notice.



Size #23 Copper Alloy Crimp Contacts

Size #23 Copper Alloy Crimp Contacts



#23 Pin Contact



#23 Socket Contact

Contact Type	Wire Size	Material	Part Number	In.	Ø A mm.	Color Band	Tool Code
Pin	#22 - #28	BeCu	809-001	.0335-.0355	0.851-0.902	None	A, C
Pin	#26 - #30	BeCu	809-042	.0229-.0245	0.582-0.622	Blue	A, D
Pin	#22 - #28	Alumel	809-065A	.0335-.0355	0.851-0.902	None	A, C
Pin	#22 - #28	Chromel	809-065C	.0335-.0355	0.851-0.902	None	A, C
Socket	#22 - #28	BeCu	809-002	.0335-.0355	0.851-0.902	None	A, C
Socket	#26 - #30	BeCu	809-043	.0229-.0245	0.582-0.622	Blue	A, D
Socket	#22 - #28	Alumel	809-066A	.0335-.0355	0.851-0.902	None	A, C
Socket	#22 - #28	Chromel	809-066C	.0335-.0355	0.851-0.902	None	A, C

Standard size #23 contacts accept #22 to #28 AWG wire. Choose "small bore" versions for #26 to #30 AWG wire. For thermocouple applications, specify alumel or chromel contacts. Contacts are bulk packaged. Terminate with standard M22520 crimper with special positioner.

CRIMP TENSILE STRENGTH

Values are in pounds and are minimums.

Wire Gage	Silver or Tin Coated Copper Wire	Nickel Coated Copper Wire
#22	12	8
#24	8	6
#26	5	3
#28	3	2
#30	1.5	1.5

#23 Pin Contact

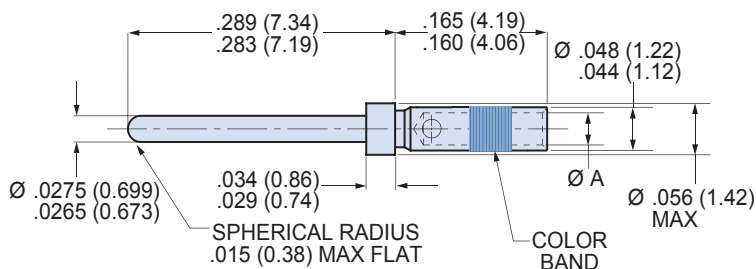

#23 Socket Contact

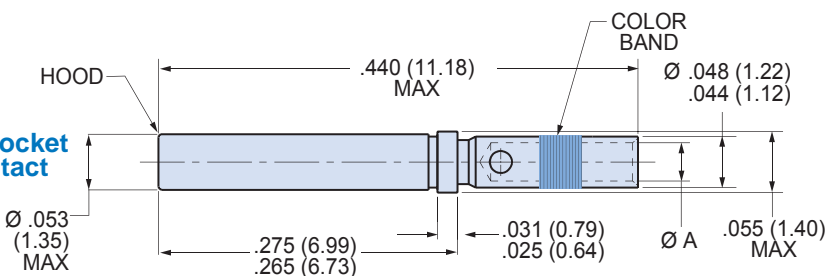

Material and Finish

- Copper alloy per ASTM B196 or B197, 50 microinches gold plated per ASTM B488 Type 3 Code C Class 1,27 over nickel plate per QQ-N-290 Class 2, 50-100 microinches.
- Thermocouple contacts: alumel or chromel alloy, unplated, per ANSI 96.1
- Socket contact hood: stainless steel, passivated per AMS-QQ-P-35.

Specifications

- Current Rating: 5 Amps maximum
- Voltage Drop (at 5 Amps and 25° C): 70 millivolts maximum
- Temperature Range: -65° to + 200° C
- Socket Contact Minimum Separation Force: 0.5 ounces

Crimp Tools and Insertion/Removal Tools

- Crimper: 809-015
- Positioner: 809-005 (standard). Use P/N 809-057 for small bore contacts 809-065 and 809-066
- Standard Insertion/Removal Tool: 809-088

Dimensions in Inches (millimeters) are subject to change without notice.

Size #23 Copper Alloy Crimp Contacts Termination, Installation and Removal



How to Terminate, Install and Remove Size #23 Contacts

- 1** Set Up Crimp Tool. Install proper positioner into crimp tool. The label on the positioner shows the proper tool setting for each wire size. Turn the adjustment wheel to the correct setting.
- 2** Strip Wire. Remove wire insulation, taking care to avoid nicking or cutting wire strands. Strip wire to length shown.
- 3** Insert wire into contact. The wire should be visible in the inspection hole.
- 4** Insert contact into crimp tool as shown. Make sure that the contact is fully inserted into the tool. Squeeze handle completely. The ratchet mechanism will not allow a partial crimp. Release handle and remove contact.
- 5** Inspect crimped contact. Wire should be fully inserted and the crimp should be uniform in appearance.

Insertion/Extraction Tool 809-088

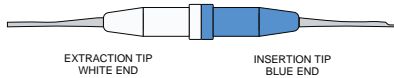

- 6** Install contact into connector. Push the contact through the rear grommet until the contact locks into place. This can usually be done by hand without the need for a tool. If the wire gage is #26 or smaller, a tool is helpful. There are two techniques for installing contacts with a tool. One method is to push the contact in by hand, then use the tool to finish the insertion. The other method is to position the insertion tip against the contact shoulder, then insert the contact. Use insertion/extraction tool 809-088 to install contacts. Slide the wire into the groove on the blue end of the tool. Slide the tool tip up the contact until it touches the contact shoulder. **USE CARE TO AVOID DAMAGING THE CONNECTOR.**

- 7** Contact Extraction. Use tool 809-088. The white end is used for contact extraction. First, push the wire into the groove of the metal tip. Slide the tip of the tool into the connector. Push the tool into the connector cavity until the tip bottoms in the connector. Avoid wiggling or rocking the tip. This may damage the cavity. A straight push is best. Pinch the wire between your finger and the white plastic grip and slide the tool and contact out of the connector. Wire insulation diameter greater than 0.045 inches (1.14mm) is too large to work properly with the extraction tool. connector damage is possible.

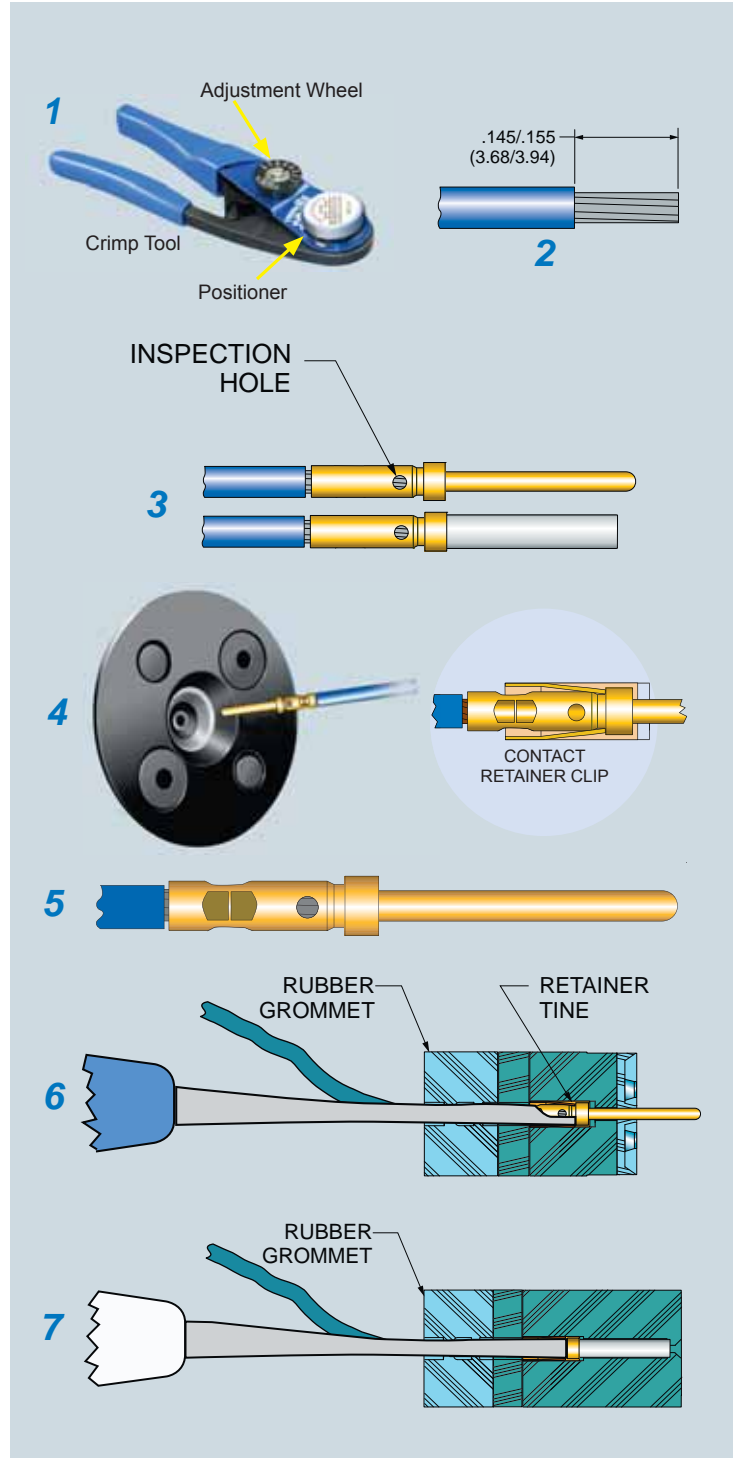

Dimensions in Inches (millimeters) are subject to change without notice.



Adapter for Crimping #20 AWG Wire to Size 23 Contacts; Size 16 Power Contacts; Size 12 Power Contacts

Adapter for Crimping #20 AWG Wire to Size #23 Series 79 Contacts

Size #22 AWG wire is the largest wire size that fits standard size 23 contacts. Use this adapter to attach larger #20 gage wire. First, crimp wire to adapter, then crimp the adapter into the size #23 contact. Adapters are made of tellurium copper alloy #1452, and are gold plated. Crimp with M22520/1-01 tool and 809-138 (Daniels TH653) positioner. These adapters cannot be removed from connectors.



#20 AWG Wire Adapter

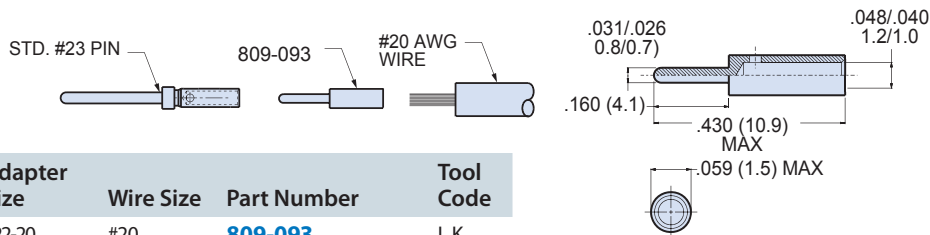

Adapter Size	Wire Size	Part Number	Tool Code
#22-20	#20	809-093	I, K

Size #16 Power Contacts, Crimp Termination

Standard size #16 contacts accept #16 to #20 AWG wire. At rated test current of 13 amps, the maximum voltage drop is 74 millivolts. Contacts are gold-plated copper alloy. Socket contacts feature stainless steel hoods to protect against probe damage. Approved to SAE-AMS-39029. Contacts are bulk packaged. Terminate with M22520/1-01 crimper and M22520/1-04 positioner.



#16 Pin Contact

#16 Socket Contact

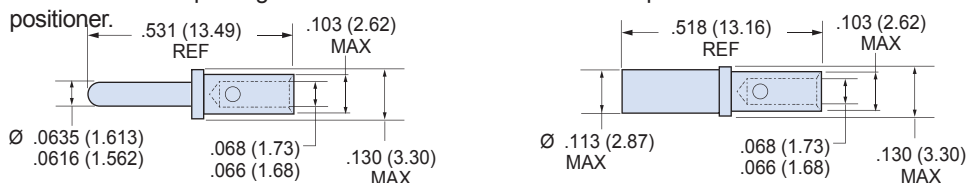

Contact Type	Wire Size	Part Number	Military Part Number	Color Band			Tool Code
				1st	2nd	3rd	
Pin	#16 - #20	809-110	M39029/58-364	Orange	Blue	Yellow	I, J
Socket	#16 - #20	809-111	M39029/57-358	Orange	Green	Gray	I, J

Size #12 Power Contacts, Crimp Termination

Standard size #12 contacts accept #12 to #14 AWG wire. At rated test current of 23 amps, the maximum voltage drop is 63 millivolts. Contacts are gold-plated copper alloy. Socket contacts feature stainless steel hoods to protect against probe damage. Approved to SAE AS39029. Contacts are bulk packaged. Terminate with M22520/1-01 crimper and M22520/1-04 positioner.



#12 Pin Contact

#12 Socket Contact

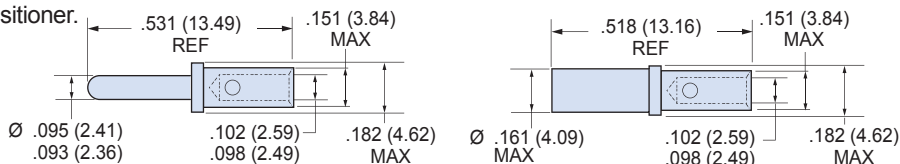

Contact Type	Wire Size	Part Number	Military Part Number	Color Band			Tool Code
				1st	2nd	3rd	
Pin	#12 - #14	809-112	M39029/58-365	Orange	Blue	Green	I, J
Socket	#12 - #14	809-113	M39029/57-359	Orange	Green	White	I, J

Dimensions in Inches (millimeters) are subject to change without notice.

Size #16 Coaxial Contacts, Crimp Termination

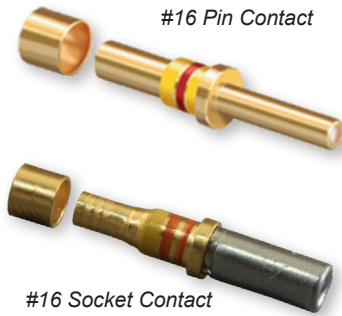

These #16 contacts accept 50 ohm and 75 ohm coaxial cable. Inner contact is rated at 1 amp, the outer contact 12 amps. DWV voltage rating is 800 Vac rms sea level, 250 Vac at 50,000 feet. Contacts are packaged individually and are unassembled with instruction sheet. One contact consists of outer contact, fluorocarbon dielectric, inner contact and shield crimp sleeve. Inner and outer contacts are gold-plated copper alloy. Approved to SAE AS39029. VSWR rating 1.5:1 maximum up to 700 MHz. 5000 megohm insulation resistance.

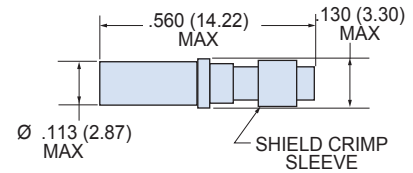
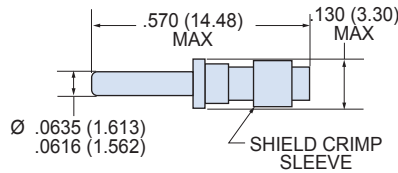

Type	Cable Size	Part Number	Military Part Number	Color Band			Tool Code
				1st	2nd	3rd	
Pin	RG174, RG316, RG179	809-114	M39029/76-424	Yellow	Red	Yellow	A, E, L, M
Pin	RG178	809-115	M39029/76-425	Yellow	Red	Green	A, E, L, M
Socket	RG174, RG316, RG179	809-116	M39029/78-432	Yellow	Orange	Red	A, E, L, M
Socket	RG178	809-117	M39029/78-433	Yellow	Orange	Orange	A, E, L, M

Size #12 Coaxial Contacts, Crimp Termination

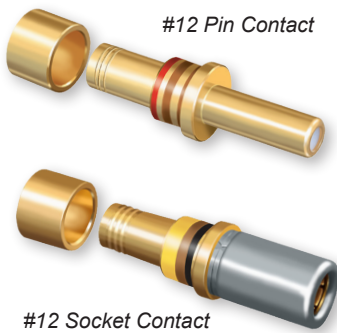

These #12 contacts accept 50 ohm and 75 ohm coaxial cable. Inner contact is rated at 1 amp, the outer contact 12 amps. DWV voltage rating is 1000 Vac rms sea level, 250 Vac at 50,000 feet. Contacts are packaged individually and shipped unassembled with instruction sheet. One contact consists of outer contact, fluorocarbon dielectric, inner contact and shield crimp sleeve. Inner and outer contacts are gold-plated copper alloy. Approved to SAE AS39029. VSWR rating 1.5:1 maximum up to 700 MHz. 5000 megohm insulation resistance.

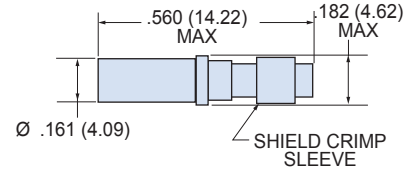
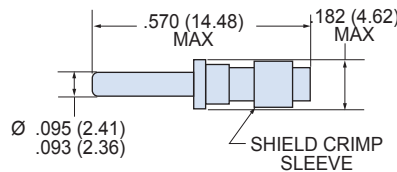

Type	Cable Size	Part Number	Military Part Number	Color Band			Tool Code
				1st	2nd	3rd	
Pin	RG174, RG316, RG179	809-118	M39029/28-211	Red	Brown	Brown	A, G, N, O
Pin	RG180	809-119	M39029/28-409	Yellow	Black	White	A, G, N, O
Socket	RG174, RG316, RG179	809-120	M39029/27-210	Red	Brown	Black	A, G, N, O
Socket	RG180	809-121	M39029/27-402	Yellow	Black	Red	A, G, N, O

Dimensions in Inches (millimeters) are subject to change without notice.

Size #12 50 Ohm Matched Impedance Coaxial Contacts



These contacts offer improved frequency response compared to standard coaxial contacts above. VSWR is 1.32:1 at 3GHz. Nominal impedance is 50 ohms. Insertion loss at 3GHz is 0.20 dB maximum. Inner contact is rated at 1 amp, the outer contact 12 amps. DWV voltage rating is 1000 Vac rms sea level, 250 Vac at 50,000 feet. Contacts are packaged individually and shipped unassembled with instruction sheet. One contact consists of outer contact, fluorocarbon dielectric, inner contact and shield crimp sleeve. Inner and outer contacts are gold-plated copper alloy. 5000 megohm insulation resistance. Terminate crimp type coaxial center contact with hand tool 809-128 (Daniels MH992). Terminate cable braid to contact with 809-129 (Daniels HX4) parallel action crimp tool and 809-120 (Daniels Y196) hex die.

Contact Type	Cable Type	Part Number	Termination	Fig.	Tool Code
Pin	RG178	852-016-03	Crimp	1	B, F, P, Q
Pin	M17/113-RG316	852-016-01	Crimp	1	B, H, P, Q
Pin	M17/152-00001(RG316DS)	852-016-02	Crimp	1	B, H, P, Q
Pin	TFLEX-405	852-018	Solder	2	(No Tool)
Socket	RG178	852-015-03	Crimp	3	B, F, P, Q
Socket	M17/113-RG316	852-015-01	Crimp	3	B, H, P, Q
Socket	M17/152-00001(RG316DS)	852-015-02	Crimp	3	B, H, P, Q
Socket	TFLEX-405	852-017	Solder	4	(No Tool)

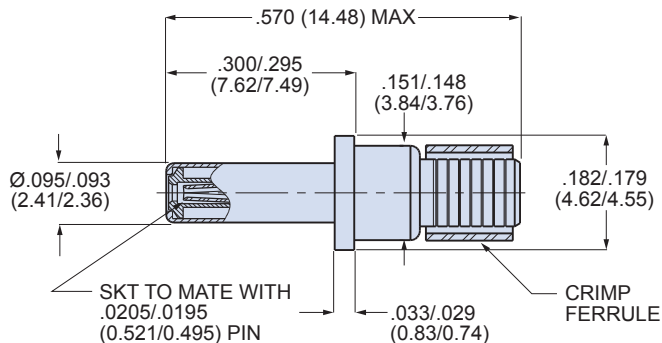

Figure 1

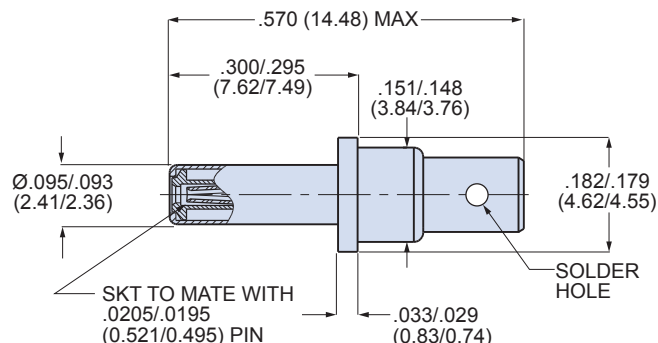

Figure 2

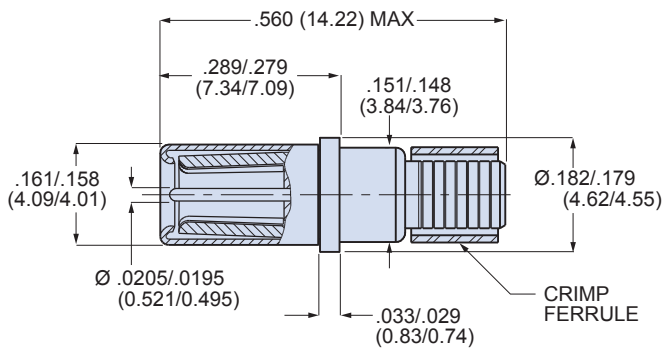

Figure 3

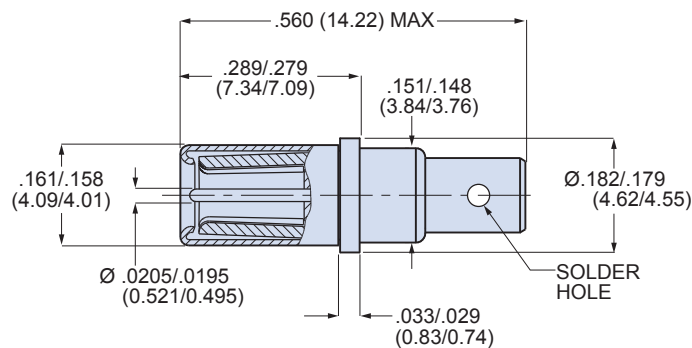

Figure 4

Dimensions in Inches (millimeters) are subject to change without notice.

Size #12 Pneumatic Contacts

Stainless steel pneumatic contacts attach to 3/32 inch (2.38) diameter tubing. Socket contact has o-ring and PTFE backup washers. Contacts snap into size #12 connector cavities. Ideal for pitot tube connections, these pneumatic contacts are rated for 100 PSI maximum air pressure. No installation tool is required. Remove contacts with plastic extraction tool 809-132.



#12 Pin Contact



#12 Socket Contact



Blind mate panel mount connector with pneumatic size #12 contacts

Material and Finish

Body and Cap: stainless steel, passivated
O-ring: fluorosilicone
Washers: PTFE

Contact Type	Tube I.D.	Part Number	
Pin	.094 (2.38)	830-003	830-003 supersedes 857-011
Socket	.094 (2.38)	830-004	830-004 supersedes 857-010

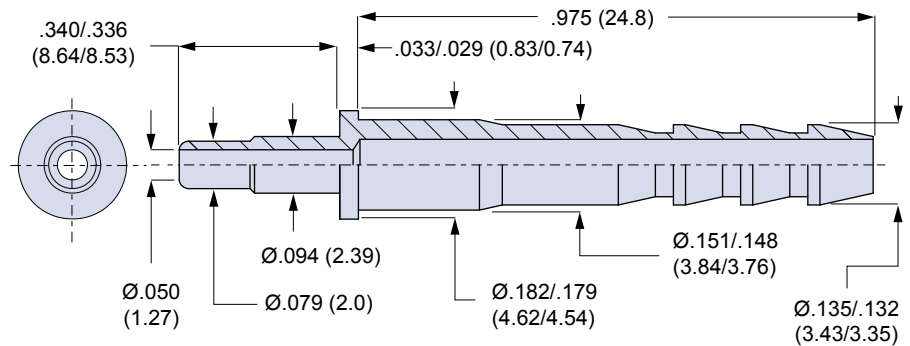

830-003 Pin Contact

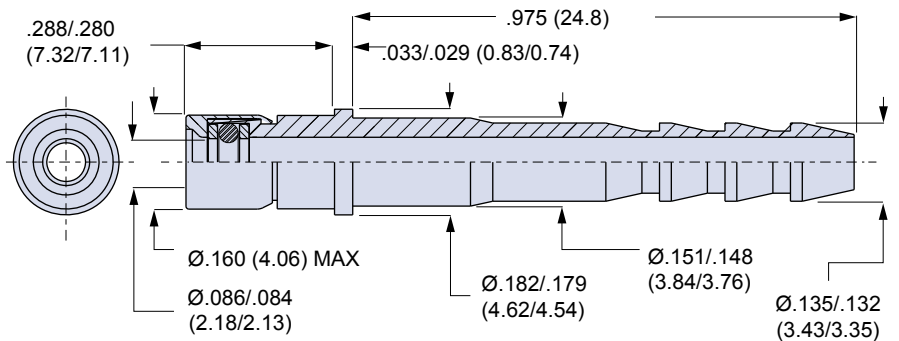

830-004 Socket Contact

Dimensions in Inches (millimeters) are subject to change without notice.

Miniature Adjustable Crimp Tools

These crimp tools perform precision eight indent crimps for gas-tight wire terminations and excellent tensile strength. Adjustment wheel has 8 settings. Ratchet mechanism prevents improper crimps. Use with bayonet-type positioners. Check calibration with M22520/3 gages. Length is 6.75 inches, weight is approx. 10 oz.



A Standard M22520/2-01 crimper. Use with standard size #23 "Mighty Mouse" contacts and with M39029/76 and /78 coaxial center contacts. Requires positioner, ordered separately.

B Special MH992 crimper used with 50 ohm matched impedance coaxial inner contacts. Requires positioner, ordered separately.

Figure	Part Number	Military Part Number	Daniels Part Number	Tool Code
A	809-015	M22520/2-01	AFM8	A
B	809-128	(none)	MH992	B

Positioners for Use with Miniature Adjustable Crimp Tools

These bayonet-type positioners hold contacts at correct height for crimping with M22520/2 type miniature step adjustable tools, above. Face plate shows correct tool settings.



C Positioner for standard size #23 contacts. #22-#28 AWG. Use with 809-015 crimp tool.

F Positioner for matched impedance #12 coaxial inner contact. Use with 809-128 crimp tool.

D Positioner for small bore size #23 contacts. #26-#30 AWG. Use with 809-015 crimp tool.

G Positioner for M39029/27 and 28 #12 coaxial inner contact. Use with 809-015 crimp tool.

E Positioner for M39029/76 and 78 coaxial inner contact. Use with 809-015 crimp tool.

H Positioner for matched impedance #12 coaxial inner contact. Use with 809-128 crimp tool.

Figure	Part Number	Military Part Number	Daniels Part Number	Tool Code
C	809-005	(none)	K1461	C
D	809-057	(none)	(none)	D
E	809-125	M22520/2-35	K532-1	E
F	809-124	(none)	K1360	F
G	809-135	M22520/2-34	K323	G
H	859-006	(none)	K1721	H

Crimp Tool and Positioner for #12 and #16 Power Contacts and 809-093 Adapters



I Crimp tool for use with size #16 and #12 power pins. 9.75 inches OAL, 1.25 pounds. Use with M39029/57 and /58 contacts and 809-093 adapters.

J Positioner for use with size #12 and #16 Power contacts.

K Positioner for use with 809-093 adapters.

Figure	Part Number	Military Part Number	Daniels Part Number	Tool Code
I	809-136	M22520/1-01	AF8	I
J	809-137	M22520/1-04	TH163	J
K	809-138	(none)	TH653	K

Dimensions in Inches (millimeters) are subject to change without notice.

Crimp Tool and Positioner for #16 Coaxial Outer Contact

For crimping size #16 shield sleeves. These mil spec approved tools feature a ratchet mechanism to prevent damage from overcrimping. Check calibration with M22520/3 gage.



L Crimp tool for use with size #16 coaxial contacts. Blue handles. 9.75 inches OAL, 1.25 pounds.

M Positioner for use with size #16 coaxial contacts. Use with 809-127 (M22520/4-01) crimp tool.

Figure	Part Number	Military Part Number	Daniels Part Number	Tool Code
L	809-127	M22520/4-01	GS100-1	L
M	809-126	M22520/4-02	GP295	M

Crimp Tool and Positioner for #12 Coaxial Outer Contact

For crimping size #12 shield sleeves. These mil spec approved tools feature a ratchet mechanism to prevent damage from overcrimping. Check calibration with M22520/3 gage.



N Crimp tool for use with size #12 coaxial contacts. Black handles. 9.75 inches OAL, 1.25 pounds.

O Positioner for use with size #12 coaxial contacts. Use with 809-133 (M22520/31-01) crimp tool.

Figure	Part Number	Military Part Number	Daniels Part Number	Tool Code
N	809-133	M22520/31-01	GS200-1	N
O	809-134	M22520/31-02	G2P330	O

Parallel Action Crimp Tool and Hex Die Set for 50 Ohm Matched Impedance #12 Coax



P Parallel action tool for use with hex crimp dies. 11 inches OAL, 2.0 pounds. Anodized aluminum frame, steel mechanism, plastic handles. Includes tool for die set removal. Accepts all M22520/5 die sets.

Q Die set for terminating coaxial shield to outer contact. Use with size #12 matched impedance M39029/102 and 103 type coaxial contacts. Set consists of upper and lower halves. Made of hardened steel with black oxide finish. Approximately 2 inches in length, assembled. Die set has two closures per illustration.

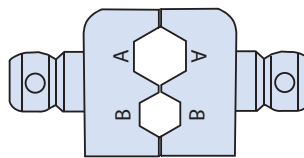

A .128 (3.25) HEX
B .105 (2.67) HEX



Figure	Part Number	Military Part Number	Daniels Part Number	Tool Code
P	809-129	M22520/5-01	HX4	P
Q	809-130	M22520/5-03	Y196	Q

Dimensions in Inches (millimeters) are subject to change without notice.

Contact Insertion and Removal Tools



1 Insertion/Extraction Tool for #23 Contacts. This economical tool features molded plastic grips and sturdy stainless steel tips.



2 Insertion Tool for #23 Contacts. This tool features anodized aluminum handle and stainless steel insertion tip.



3 Insertion/Extraction Tool for #16 Contacts. Use with size #16 coaxial or power contacts. Economical molded plastic. White extraction tip, blue insertion tip.



4 Insertion/Extraction Tool for #12 Contacts. Use with size #12 coaxial or power contacts. Economical molded plastic. White extraction tip, yellow insertion tip.

Figure	Size	Type	Part Number	Military Part Number	Daniels Part Number
1	#23	Insertion/Extraction	809-088	(None)	(None)
2	#23	Insertion Only	809-013	(None)	DAK225-22
3	#16	Insertion/Extraction	809-131	M81969/14-03	(None)
4	#12	Insertion/extraction	809-132	M81969/14-04	(None)

Contact Retention Tester for Size #23 Contacts



Check for properly seated contacts with this spring-loaded tester. Apply the tool tip to the mating end of a contact. Push on the handle until the spring compresses to the recommended force. A visual indicator shows full compression. The contact is properly retained if it is not displaced.

The adjustable handle should be set to 3.2 pounds (14.2 N). The pin tip is used with #23 pin contacts. The socket tip is used with #23 socket contacts.

Order the complete kit, or order the tips and handle separately.

Figure	Description	Part Number	Daniels Part Number
1	Handle	809-107-1	HT250-2
2	Pin Tip	809-107-2	68-023-01
	Socket Tip (not shown)	809-107-3	67-023-01
	Complete Kit	809-107-4	(None)

Dimensions in Inches (millimeters) are subject to change without notice.

Band-Master™ Advanced Termination System

Fast, Cost-Effective Shield Termination

Attach cable braid shields to EMI backshells with **Band-Master™ ATS** stainless steel straps. The **Band-Master™ ATS** system offers fast termination and the flexibility to handle different diameters with the same band.

IMPORTANT NOTE: ALWAYS DOUBLE-WRAP BANDS!

Contact Glenair or visit our website (glenair.com) to view our complete line of **Band-Master™ ATS** products, including pneumatic tools for high production and calibration kits.



Micro Band Tool
Part Number **600-061**
Standard Band Tool
Part Number **600-058**
1.18 lbs.
6.75 Inches (172mm.) Length

B



Step One: Cable Prep

Lay individual shields over the band platform. Pull overall braid shield over the band platform so that all braid strands will be captured by the band.



Step Two: Install Band

Wrap the band through the buckle twice. Insert the free end into the banding tool in the direction shown on the tool. Squeeze the short grey handle to insert the band. Slide the band onto the cable. Close the black handle repeatedly until the handle no longer opens. Close the long grey handle until the tool cuts the band. Remove the excess band from the tool by closing the small grey handle.



Step Three: Trim Braid

It's a snap! Just trim the excess braid and you're done.

HOW TO ORDER BANDS

Band Type	Width		Length		Part Number		Use With Tool	Accommodates Dia.	
	In.	mm.	In.	mm.	Uncoiled	Coiled		In.	mm.
Micro Band, Standard Length	.120	3.05	8.125	206.38	600-057	600-057-1	600-061	.88	22.35
Micro Band, Extended Length	.120	3.05	14.25	361.95	600-083	600-083-1	600-061	1.88	47.75
Standard Band, Standard Length	.240	6.10	14.256	362.10	600-052	600-052-1	600-058	1.80	45.72
Standard Band, Extended Length	.240	6.10	18.00	457.20	600-090	600-090-1	600-058	2.50	63.50

Dimensions in Inches (millimeters) are subject to change without notice.

SERIES 79

MICRO-CRIMP

INSERT ARRANGEMENTS • SPECIFICATIONS • MOD CODES



Micro-D connectors are a popular choice for space flight. Their small size and reduced weight, combined with excellent shock and vibration performance, has led to their widespread use on space vehicles. The Micro-Crimp connector brings the benefits of a crimp, rear-release contact system to the Glenair Micro-D family. Connectors can be terminated onto complicated, multi-branch wiring harnesses without splicing or soldering. Specifying a Series 79 Micro-Crimp connector for space flight may include NASA screening and outgassing processing (managed with simple mod codes) or material and plating selections such as the gold-plated micro-crimp connector shown above. See page C-9 for the complete range of material and plating options.



Micro-Crimp Insert Arrangements

How To Order Connectors for Use with Coaxial or Pneumatic Contacts

Coaxial and pneumatic contacts are ordered separately. Series 79 connectors can be ordered without size #16 or #12 power contacts. Change the "P" in the contact arrangement (11P2, for example) to "W" (11W2). An 11P2 connector is packaged with nine size #23 signal contacts and two size #16 power contacts. An 11W2 is supplied with nine size #23 contacts only.

Contact Arrangement Nomenclature Explained

The first letter represents the shell size. The number following the shell size represents the total number of contacts. If the insert arrangement is a mixed layout with signal contacts and coaxial/power contacts, the letter "W" specifies the connector to be furnished with signal contacts only (coax/power contacts purchased separately), and the letter "P" specifies the connector to be furnished with both signal and power contacts.

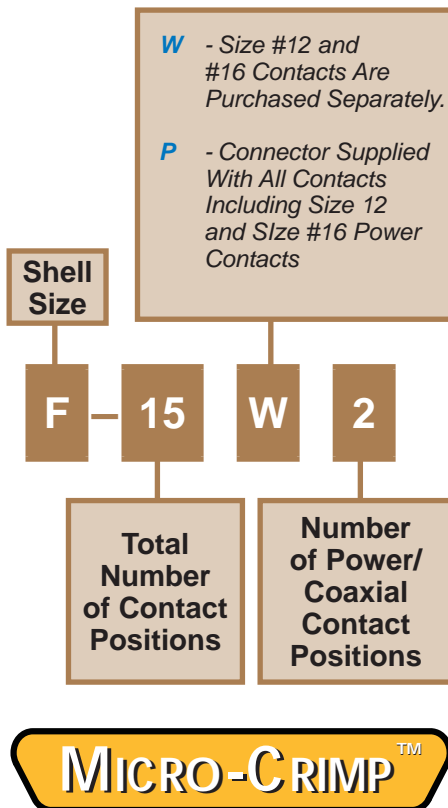

Shell Size	Contact Arrangement	Contact Quantity		
		#23	#16	#12
A	A-5	5	—	—
B	B-2P2	—	2	—
	B-9	9	—	—
C	C-13	13	—	—
D	D-15	15	—	—
	D-3P3	—	3	—
E	D-7P2	5	2	—
	E-11P2	9	2	—
	E-19	19	—	—
F	E-7P3	4	3	—
	F-15P2	13	2	—
	F-23	23	—	—
G	F-5P5	—	5	—
	G-33	33	—	—
H	H-10P4	6	—	4
	H-29P7	22	7	—
	H-36P2	34	—	2
	H-54P2	52	2	—
	H-5P5	—	—	5
J	H-66	66	—	—
	J-17P4	13	4	—
	J-25P2	23	2	—
	J-33	33	—	—
K	J-7P7	—	7	—
	K-27P4	23	4	—
	K-35P2	33	2	—
	K-43	43	—	—
L	K-9P9	—	9	—
	L-6P6	—	—	6
M	L-78	78	—	—
	M-102	102	—	—

Dimensions in Inches (millimeters) are subject to change without notice.



Series 79 Micro-Crimp General Information Insert Arrangements

MICRO-CRIMP INSERT ARRANGEMENTS

Shell Size	Contact Arrangement	No. of Contacts and Contact Size	Mating Face Pin Connector (Socket Numbers are Reversed)
A	A-5	5 #23 CONTACTS	
B	B-2P2 B-2W2	2 #16 CONTACTS	
B	B-9	9 #23 CONTACTS	
C	C-13	13 #23 CONTACTS	
D	D-15	15 #23 CONTACTS	
D	D-3P3 D-3W3	3 #16 CONTACTS	
D	D-7P2 D-7W2	5 #23 CONTACTS 2 #16 CONTACTS	
E	E-11P2 E-11W2	9 #23 CONTACTS 2 #16 CONTACTS	
E	E-19	19 #23 CONTACTS	
E	E-7P3	4 #23 CONTACTS 3 #16 CONTACTS	
F	F-15P2 F-15W2	13 #23 CONTACTS 2 #16 CONTACTS	
F	F-23	23 #23 CONTACTS	
F	F-5P5 F-5W5	5 #16 CONTACTS	
G	G-33	33 #23 CONTACTS	

Dimensions in Inches (millimeters) are subject to change without notice.

Series 79 Micro-Crimp General Information Insert Arrangements



MICRO-CRIMP INSERT ARRANGEMENTS

Shell Size	Contact Arrangement	No. of Contacts and Contact Size	Mating Face Pin Connector (Socket Numbers are Reversed)
H	H-10P4 H-10W4	6 #23 CONTACTS 4 #12 CONTACTS	
H	H-29P7	22 #23 CONTACTS 7 #16 CONTACTS	
H	H-36P2 H-36W2	34 #23 CONTACTS 2 #12 CONTACTS	
H	H-54P2 H-54W2	52 #23 CONTACTS 2 #16 CONTACTS	
H	H-5P5 H-5W5	5 #12 CONTACTS	
H	H-66	66 #23 CONTACTS	
J	J-17P4 J-17W4	13 #23 CONTACTS 4 #16 CONTACTS	

C

Dimensions in Inches (millimeters) are subject to change without notice.



Series 79 Micro-Crimp General Information Insert Arrangements

MICRO-CRIMP INSERT ARRANGEMENTS

Shell Size	Contact Arrangement	No. of Contacts and Contact Size	Mating Face Pin Connector (Socket Numbers are Reversed)
J	J-25P2 J-25W2	23 #23 CONTACTS 2 #16 CONTACTS	
J	J-33	33 #23 CONTACTS	
J	J-7P7 J-7W7	7 #16 CONTACTS	
K	K-27P4 K-27W4	23 #23 CONTACTS 4 #16 CONTACTS	
K	K-35P2 K-35W2	33 #23 CONTACTS 2 #16 CONTACTS	
K	K-43	43 #23 CONTACTS	
K	K-9P9 K-9W9	9 #16 CONTACTS	
L	L-6P6 L-6W6	6 #12 CONTACTS	
L	L-78	78 #23 CONTACTS	
M	M-102	102 #23 CONTACTS	

Dimensions in Inches (millimeters) are subject to change without notice.

Series 79 Micro-Crimp General Information Materials, Finishes, and Specifications



MATERIALS AND FINISHES

Size #23 contacts	Beryllium copper alloy, plated gold over nickel
Size #16 and #12 contacts	Copper alloy
Insulators	Liquid crystal polymer, 30% glass-reinforced
Shell	Aluminum alloy. See ordering info for finish options
Interfacial seal and grommet	Fluorosilicone
Contact and insert retention clips	Beryllium copper, heat-treated, unplated
Jackposts and guide pins	Stainless steel, passivated
EMI Shroud for right angle PCB	Aluminum alloy
Trays for right angle PCB	Thermoplastic
Spring, EMI (plug)	Stainless steel or beryllium copper alloy, gold plated

BASIC SPECIFICATIONS

Current rating	Contact size #23 5 Amps, size #16 13 Amps, size #12 23 Amps maximum
Voltage rating (DWV)	Contact size #23 500 VAC rms. Size #16 and #12 1800 VAC rms. Sea level.
Insulation resistance	5000 megohms minimum
Operating temperature	-65° C. to +150° C.
Contact resistance	5 milliohms maximum
Water ingress protection	IP67
Shielding effectiveness	>75 dB attenuation from 100 MHz to 1000MHz, >60dB 1GHz to 4GHz, >40dB 4GHz to 10GHz.

DETAILED PERFORMANCE SPECIFICATIONS

DESCRIPTION

REQUIREMENT

PROCEDURE

Contact Resistance

SAE AS39029 Table V

EIA-364-06

IEC 60512-2-1

Test current in amperes. Voltage drop in millivolts. Silver-coated copper wire, +25°C.

Max Wire Size	Test Current	Voltage Drop
12	23	42
14	17	40
16	13	49
20	7.5	55
22	5	73
24	3	45
26	2	52
28	1.5	54

Low Level Contact Resistance

Wire Size Max. Milliohms

EIA-364-23

100 milliamperes maximum and 20 millivolts maximum open circuit voltage

16	5
20	9
22	15
24	20
26	31
28	50

Insulation Resistance

5000 megohms minimum

EIA-364-21 / IEC-60512-3-1

500 volts DC ± 50 volts. Test between adjacent contacts and contacts to shell.



Series 79 Micro-Crimp General Information Performance Specifications

DETAILED PERFORMANCE SPECIFICATIONS

DESCRIPTION	REQUIREMENT	PROCEDURE								
Dielectric Withstanding Voltage	No breakdown or flashover	EIA-364-20 IEC-60512-4-1 Sea level AC rms 50 or 60 Hz. One minute dwell. #23 contacts 500 volts #16 contacts 1800 volts #12 contacts 1800 volts								
Current Carrying Capacity	<table border="1"> <thead> <tr> <th>Contact Size</th> <th>Max Current</th> </tr> </thead> <tbody> <tr> <td>12</td> <td>23</td> </tr> <tr> <td>16</td> <td>13</td> </tr> <tr> <td>23</td> <td>5</td> </tr> </tbody> </table>	Contact Size	Max Current	12	23	16	13	23	5	EIA-364-70 Method 1 IEC-60512-5 Test 9b
Contact Size	Max Current									
12	23									
16	13									
23	5									
Shell-to-shell Resistance (connectors with ground springs)	2.5 millivolt drop maximum	EIA-364-83 IEC-60512-2-6 Electroless nickel plated connectors.								
Shielding Effectiveness	>75 dB attenuation from 100 MHz to 1000MHz, >60dB 1GHz to 4GHz, >40dB 4GHz to 10GHz.	EIA-364-66 IEC-60512-23-3								
Water Immersion	No evidence of water penetration into mated connectors. No evidence of water penetration into an unmated panel mounted PCB receptacle. ≥ 100 M Ω insulation resistance.	MIL-STD-810F Method 512.4 1 meter immersion 1 hour								
Ingress Protection	IP67 rating	IEC-60529								
Vibration, Sine	No discontinuity of greater than 1 microseconds, no cracking, breaking or loosening of parts, plug shall not become disengaged from receptacle. Connectors shall meet electrical requirements after vibration test.	EIA-364-28 Test Condition IV IEC-60512-6-4 100 milliamp test current 10- 2,000 Hz 20 g, 196 m/s ²								
Vibration, Random	No discontinuity of greater than 1 microseconds, no cracking, breaking or loosening of parts, plug shall not become disengaged from receptacle. Connectors shall meet electrical requirements after vibration test.	EIA-364-28 Test Condition VI Letter J IEC-60512-6-4 100 milliamp test current 50- 2,000 Hz 43.92 g rms								

Dimensions in Inches (millimeters) are subject to change without notice.

Series 79 Micro-Crimp General Information Performance Specifications



DETAILED PERFORMANCE SPECIFICATIONS

DESCRIPTION	REQUIREMENT	PROCEDURE
Mechanical Shock	No discontinuity of greater than 1 microsecond, no cracking, breaking or loosening of parts, plug shall not become disengaged from receptacle. Connectors shall meet electrical requirements after shock test.	EIA-364-27 Condition D IEC-60512-6-3 3 shocks X 3 axes X 2 directions = 18 shocks 2941 m/s ² (300 g's), 3 ms, half-sine
Thermal Shock	No mechanical damage or loosening of parts. Following thermal shock, connector shall meet contact resistance, DWV, insulation resistance and shell-to-shell resistance requirements.	EIA-364-32 Test Condition IV IEC-60512-11-4 5 cycles consisting of -65° C 30 minutes, +25° C 5 minutes max., +150° C 30 minutes, +25° C 5 minutes max.
Humidity, Cyclic (Damp Heat, Cyclic) (Moisture Resistance)	No deterioration which will adversely affect the connector. 100 megohms minimum insulation resistance during the final cycle. Following the recovery period, connectors shall meet contact resistance, shell-to-shell resistance and DWV requirements.	EIA-364-31 Condition B Method III IEC-60512-11-12 80-98% RH 10 cycles (10 days) +25° C to +65° C Step 7b vibration deleted. 24 hour recovery period.
Mechanical Durability, at Ambient Temperature	No deterioration which will adversely affect the connector after 2000 cycles of mating and unmating. Connectors shall meet contact resistance, insulation resistance, shell-to-shell resistance, DWV, and mating and unmating force.	EIA-364-09 IEC-60512-5 Test 9a
Corrosion (Salt Mist)	Unmated connectors shall show no lifting of plated coating or exposure of basis material under power (3X) magnification which adversely effects DWV and contact resistance performance when evaluated.	EIA-364-26 IEC 60512-11-6 5% salt solution 35° C Unmated connectors Code MT: Ni-PTFE 500 hours Code M: electroless nickel 48 hours Code NF: Cadmium 500 hours Code ZNU: Black zinc nickel 500 hours
Solderability, PC Tail Contacts	95% solder coverage. Smooth, bright and even finish.	EIA-364-52 Category 3 IEC-60512-12-1 IEC-68-2-20 Test Ta, method 1 8 hours steam aging prior to test 245° C 4-5 sec. dwell 10X magnification

Dimensions in Inches (millimeters) are subject to change without notice.



Series 79 Micro-Crimp General Information Performance Specifications

DETAILED PERFORMANCE SPECIFICATIONS

DESCRIPTION	REQUIREMENT	PROCEDURE															
Resistance To Soldering Heat	No damage to connector. Connectors shall meet insulation resistance and waterproof sealing requirements.	EIA-364-56 IEC-60512-12-5 Test 12e 260° C, 10 seconds (PC tail)															
Impact, Cable Connectors	No impairment of function. Connector shall meet contact resistance, insulation resistance and waterproof sealing.	EIA-364-42 IEC-60512-5 test 7b 1 meter 8 drops															
Fluid Immersion	No damage from immersion in various fuels and oils. Connector shall meet mating/unmating force and dielectric withstanding voltage.	EIA-364-10															
Altitude Immersion	No evidence of moisture on connector interface or contacts. Connector shall meet dielectric withstanding voltage.	EIA-364-03 Wired connectors with supplemental potting.															
Contact Retention	<table border="1"> <thead> <tr> <th>Contact Size</th> <th>Min. Pounds</th> <th>Min. Newtons</th> </tr> </thead> <tbody> <tr> <td>23</td> <td>6</td> <td>27</td> </tr> <tr> <td>20</td> <td>15</td> <td>67</td> </tr> <tr> <td>16</td> <td>25</td> <td>111</td> </tr> <tr> <td>12</td> <td>25</td> <td>111</td> </tr> </tbody> </table>	Contact Size	Min. Pounds	Min. Newtons	23	6	27	20	15	67	16	25	111	12	25	111	EIA-364-29
Contact Size	Min. Pounds	Min. Newtons															
23	6	27															
20	15	67															
16	25	111															
12	25	111															
Contact Separation Force	<table border="1"> <thead> <tr> <th>Contact Size</th> <th>Min. Ounces</th> <th>Min. Newtons</th> </tr> </thead> <tbody> <tr> <td>23</td> <td>0.5</td> <td>0.14</td> </tr> <tr> <td>20</td> <td>0.7</td> <td>0.19</td> </tr> <tr> <td>16</td> <td>2.0</td> <td>0.56</td> </tr> <tr> <td>12</td> <td>3.0</td> <td>0.83</td> </tr> </tbody> </table>	Contact Size	Min. Ounces	Min. Newtons	23	0.5	0.14	20	0.7	0.19	16	2.0	0.56	12	3.0	0.83	SAE AS39029
Contact Size	Min. Ounces	Min. Newtons															
23	0.5	0.14															
20	0.7	0.19															
16	2.0	0.56															
12	3.0	0.83															
Mating and Unmating Force	Maximum mating/unmating force: (6 pounds) + (# of size 23 contacts X .40) + (# of size 12 or #16 contacts X 1.8)	EIA-364-13															
Magnetic Permeability	2 μ maximum.	EIA-364-54															

Dimensions in Inches (millimeters) are subject to change without notice.

About Series 79 Micro-Crimp Shell Plating Options



Micro-D connector shells are made of aluminum alloy and are coated to improve corrosion resistance. Electroless nickel plating is used for instrumentation, avionics and space applications where corrosion protection is not critical. Cadmium plating provides superior corrosion protection, but the United States Department of Defense (DOD) has mandated the elimination of cadmium from DOD weapons systems because of toxicity concerns. The European Union has also restricted the use of cadmium on electronics equipment (RoHS).

Glenair's 1000 Hour Grey™ nickel-PTFE plating meets the need for a high-performance cadmium replacement with excellent corrosion resistance, durability and excellent conductivity. In this catalog you will find three standard shell coatings: electroless nickel, Nickel-PTFE and black zinc-nickel. The table below shows additional plating options that are also available on any Series 79 Micro-Crimp connector.

C

MICRO-CRIMP SHELL PLATING CODES

Shell Plating	Plating Code	Salt Fog* (Hours)	Cadmium Free	Hexavalent Chromium Free	Conductivity	Compatible with EMI Spring	Typical Applications
Electroless Nickel	M	48	Yes	Yes	Excellent	Yes	Space vehicles, missiles, avionics, unmanned vehicles, instrumentation
Nickel-PTFE	MT	500	Yes	Yes	Excellent	Yes	Harsh environment, soldier systems, communications equipment
Zinc-Nickel with Black Chromate	ZNU	500	Yes	No	Good	No	Harsh environment, soldier systems, unmanned and manned vehicles
Cadmium with Olive-Drab Chromate	N	500	No	No	Excellent	No	Harsh environment, military equipment
Cadmium with Yellow Chromate	J	500	No	No	Excellent	No	General purpose military equipment
Black Anodize	C	336	Yes	Yes	Non-Conductive	N/A	Applications where EMI shielding is not required
Gold	Z2	48	Yes	Yes	Excellent	Yes	Space
Chem Film	E	48	Yes	No	Excellent	Yes	Avionics

* Salt spray test in accordance with ASTM B117

Dimensions in Inches (millimeters) are subject to change without notice.



Series 79 Micro-Crimp General Information Micro-Crimp Connectors for Space Flight

Series 79 Micro-Crimp Connectors for Space Flight



Micro-D connectors are a popular choice for space flight. Their small size and reduced weight, combined with excellent shock and vibration performance, has led to their widespread use on space vehicles. The Micro-Crimp connector brings the benefits of a crimp, rear-release contact system to the Glenair Micro-D family. Connectors can be terminated onto complicated, multi-branch wiring harnesses without splicing or soldering.

C

Five things you should know about Series 79 connectors for space flight

1 Material Selection: What materials are approved for space-grade connectors? What materials are prohibited? Does the Series 79 connector contain space-approved materials?

2 Outgassing: What is outgassing, why is it important, and how does it affect connector selection? Is special processing required to meet outgassing requirements?

3 Screening: What is NASA screening and what level of screening is required?

4 Magnetic permeability: Are nonmagnetic connectors required?

5 Cryogenic exposure: Are these connectors suitable for -200° C. exposure?



HOW TO ORDER SPACE GRADE SERIES 79 CONNECTORS

Step 1: Find a Standard Part Number

Electroless nickel plated shells are preferred for space flight. Cadmium plating is prohibited.

Step 2: Select a NASA Screening Level

The term "Screening Level" refers to the final inspection procedure.
Level 1 for mission-critical highest reliability
Level 2 for high reliability
Level 3 for standard reliability

Step 3: Choose Outgassing Processing

A detailed explanation of outgassing is on the following pages. The fluorosilicone rubber seals commonly used on aerospace-grade connectors such as MIL-DTL-38999 and Series 79 connectors, along with certain bonding agents and inks, do not meet NASA outgassing requirements unless the connector is specially processed. Glenair outgassing tests have shown oven baking or thermal vacuum outgassing processing are sufficient to reduce outgassing levels to NASA standards. Oven baking is more economical than thermal vacuum outgassing.

Step 4: Select the Mod 429 Code that Matches the Desired Level of Screening and Outgassing

Use the following table to choose the right modification code. Add the mod code to the connector part number. Example: 790-024PC-13ML-**429C**

NASA SCREENING LEVELS AND MODIFICATION CODES

NASA Screening Level	Special Screening Only		Special Screening Plus Outgassing Processing	
	Interfacial Seal is Installed	Interfacial Seal is Deleted	48 Hour Oven Bake 175° C.	Thermal Vacuum Outgassing 24 hrs. 125° C.
Level 1 Highest Reliability	Mod 429B	Mod 429F	Mod 429J	Mod 429C
Level 2 High Reliability	Mod 429	Mod 429D	Mod 429K	Mod 429A
Level 3 Standard Reliability	(Use standard part no.)	Mod 432	Mod 186	Mod 186M

Dimensions in Inches (millimeters) are subject to change without notice.



Specifying Micro-Crimp Connectors for Space Flight

1 Material Selection: What materials are approved for space flight? What materials are restricted? How to choose the right materials for Series 79 Micro-Crimp connectors.

What materials are approved for space flight?

Section C2 “Connectors and Contacts” of NASA EEE-INST-002 provides guidelines for materials used in connectors for space flight applications. Aluminum is a preferred material for connector components, and electroless nickel is the preferred finish. Beryllium copper is a preferred material for contacts. 50 microinch minimum gold plating is the preferred contact finish. LCP is a preferred material for dielectric insulating materials.

What materials are prohibited?

100% tin plating shall not be used. Pure tin can grow “whiskers” which can lead to catastrophic electrical short circuits. Silver plating is prohibited because of corrosion concerns. Cadmium is prohibited because it is unstable in vacuum environments.

Specifying Series 79 connectors for space flight

Standard Series 79 connectors meet NASA guidelines for material selection. Specify “M” for aluminum shells with electroless nickel finish. The table below lists Series 79 materials.

C

SERIES 79 CONNECTOR MATERIALS APPROVED FOR SPACE FLIGHT

Component	Material	Notes
Shells	Aluminum alloy 6061 per ASTM B211, electroless nickel plated	Approved for Space Flight
Rigid Insulators	Glass-filled liquid crystal polymer (LCP) in accordance with MIL-M-24519, Type GLP-30F	Approved for Space Flight
Retention Clips	Beryllium copper, heat-treated, unplated	Approved for Space Flight
Grommet, Interfacial Seal	Blended fluorosilicone/silicone elastomer, 30% silicone per ZZ-R-765, 70% fluorosilicone per MIL-R-25988	Requires outgassing processing
Pin Contact	Beryllium copper alloy per ASTM B197, 50 microinches gold plated per ASTM B488 Type 3 Code C Class 1,27 over nickel plate per QQ-N-290 Class 2, 50-100 microinches	Approved for Space Flight
Socket Contact	Beryllium copper alloy per ASTM B197, 50 microinches gold plated per ASTM B488 Type 3 Code C Class 1,27 over nickel plate per QQ-N-290 Class 2, 50-100 microinches.	Approved for Space Flight
Socket Contact Hood	Stainless steel, passivated per AMS-QQ-P-35	Approved for Space Flight
Adhesives	RTV and epoxies (see following table for outgassing info)	Requires outgassing processing
Potting Compound, PCB and Solder Cup Versions	Environmental and Hermetic Connectors: Stycast 2651/Catalyst 9 epoxy encapsulant. Filter Connectors: Stycast 2850FT/Catalyst 11 thermally conductive epoxy encapsulant.	Approved for Space Flight

Dimensions in Inches (millimeters) are subject to change without notice.



Specifying Micro-Crimp Connectors for Space Flight

2 Outgassing: What is outgassing and how does it affect connector selection? Is special processing required to meet outgassing requirements?

What is outgassing?

Plastic and rubber materials give off gaseous molecules. For example, the smell inside a new car is caused by polymer outgassing. Heat and vacuum increase the rate of diffusion. In a spacecraft the gases coming off polymers can contaminate optical surfaces and instruments. The result is degraded performance.

How is outgassing measured?

The space industry has adopted a standardized test procedure, **ASTM E 595**, to evaluate out-gassing properties of polymers. Small samples of material are heated to 125° C. at a vacuum of 5×10^{-5} torr for 24 hours. Then the sample is weighed to calculate the **Total Mass Loss** (TML).

The TML cannot exceed 1.00% of the total initial mass. During the test, outgassed matter condenses on a cooled collector plate. The quantity of outgassed matter is calculated to determine the **Collected Volatile Condensable Material** (CVCM). The CVCM cannot exceed 0.10% of the original specimen mass.

Is special outgassing processing necessary on Series 79 connectors?

NASA states "A bakeout for outgassing control is driven by the application and may be required where tight contamination control must be maintained." NASA generally recommends that connectors undergo outgassing processing. This processing can be performed by Glenair; however, some customers prefer to fabricate higher level subassemblies before outgassing processing is performed.

Outgassing At-a-Glance

- Fluorosilicone rubber components used in Micro-Crimp connectors, such as o-rings, grommets and seals already exceed NASA outgassing limits.
- NASA nevertheless recommends additional processing to reduce outgassing of all materials to minimal levels.
- An inexpensive oven bakeout delivers excellent results compared to thermal vacuum outgassing. The high temperature of the oven bakeout effectively removes volatile materials.
- Glenair 429 mod codes provide easy ordering, whichever outgassing option is required.

OUTGASSING PROPERTIES OF MATERIALS USED IN SERIES 79 CONNECTORS

Component	Material	TML %	TCVML %	Test Reference
Front and Rear Insulator, right angle PCB Trays	Liquid Crystal Polymer Vectra C130	0.03	0.0	NASA Test # GSC17478
Rear Grommet Interfacial Seal	Blended fluorosilicone/silicone elastomer, 30% silicone per ZZ-R-765, 70% fluorosilicone per MIL-R-25988	0.48	0.14	Glenair testing conducted at NuSil Technology 02/27/2001
Front-To-Rear Insulator Bonding Material	Eccobond 104 A/B	0.52	0.08	Emerson & Cuming Data Sheet
Insulator-to-Rubber Bonding Material	DC3145 RTV, per MIL-A-46146	1.74	0.90	NASA Test GSFC0191
PCB Trays (Machined Ultem)	Polyetherimide, Ultem 2300	0.43	0.01	NASA Test GSC19820
White Epoxy Ink for Silkscreening	Markem 7224 White	0.49	0.03	NASA Test #GSC19899
Potting Compound, PC Tail Connectors	Hysol C9-4215	0.48	0.01	Glenair Test
Panel Gasket	Silver-filled Fluorosilicone, Cho-Seal 1287	0.63	0.03	NASA test GSC15165

Dimensions in Inches (millimeters) are subject to change without notice.



Series 79 Micro-Crimp Connectors for Space Flight

3 Screening: What is NASA screening and what level of screening is required?

What is NASA screening?

NASA specification EEE-INST-002 provides instructions on selecting, screening and qualifying parts for use on NASA GSFC space flight projects. Table 2C in the NASA specification contains inspection instructions for MIL-DTL-83513 Micro-D connectors. Series 79 connectors are similar to M83513 connectors, so Table 2C applies by similarity to Series 79 connectors.

What screening level is required?

NASA defines three levels of screening: level 1 for highest reliability, level 2 for high reliability, and level 3 for standard reliability. Level 3 equates to standard lot acceptance inspection. Levels 1 and 2 call for additional testing.

What about qualification requirements?

Projects using connectors covered by military specifications are typically able to waive qualification testing. The Series 79 connector is not covered by a military specification. Projects considering using the Series 79 for space flight should obtain guidance from the overseeing space agency regarding the suitability of this connector and any testing that might be recommended.

NASA EEE-INST-002 SCREENING REQUIREMENTS		
Inspection/ Test	NASA Level 1	NASA Level 2
Visual Inspection	100%	100%
Mechanical	2 pcs.	2 pcs.
Voltage (DWV)	2 pcs.	2 pcs.
Insulation Resistance	2 pcs.	2 pcs.
Mating and Unmating Force	2 pcs.	N/A
Contact Engagement and Separation Force	2 pcs.	N/A
Air leakage (Hermetic connectors only)	100%	100%
Solderability/Resistance to Soldering Heat	2 pcs.	N/A

1. NASA screening requirements from Table 2 of EEE-INST-002 Screening Requirements.

4 Magnetic Permeability: Are nonmagnetic connectors required?

What about ferromagnetic materials?

Spacecraft designers generally avoid the use of ferromagnetic materials, which can become magnetized and can interfere with sensitive instruments. Series 79 environmental connectors have a maximum permeability of 2 mu.

5 Cryogenic exposure: Space programs sometimes need cryogenic connectors capable of withstanding temperatures as low as -270° C. Can Series 79 connectors operate satisfactorily at this temperature?

What about low temperature ranges?

Series 79 connectors are rated to -65° C. Glenair does not have data to validate these connectors for cryogenic applications. EEE-INST-002 states "...experience has proven it is possible for (non-certified) connector types to be used successfully at cryogenic temperatures. It is recommended that connector samples should be subjected to five cycles of cryogenic temperature...(followed by examination for cracks and DWV)".

Dimensions in Inches (millimeters) are subject to change without notice.

Series 79 Micro-Crimp Recommended Panel Cut-Outs

ALL CUTOUTS FOR .063" (.070 MAX) THICK PANEL MOUNTING

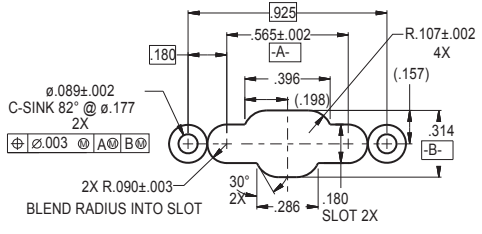

Shell Size A

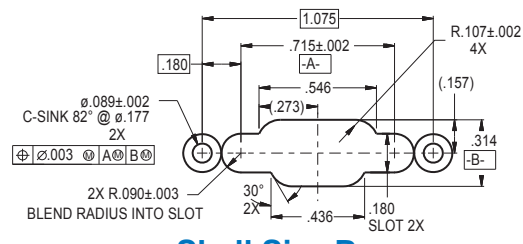

Shell Size B

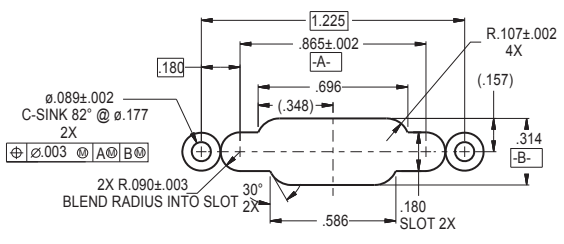

Shell Size C

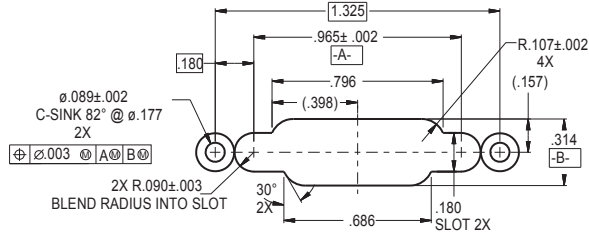

Shell Size D

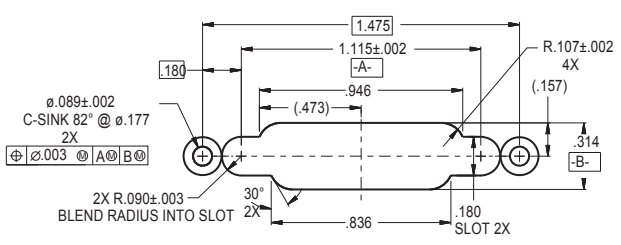

Shell Size E

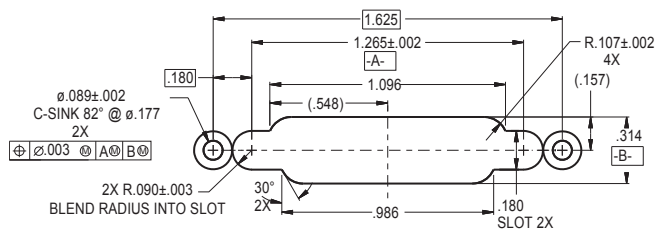

Shell Size F

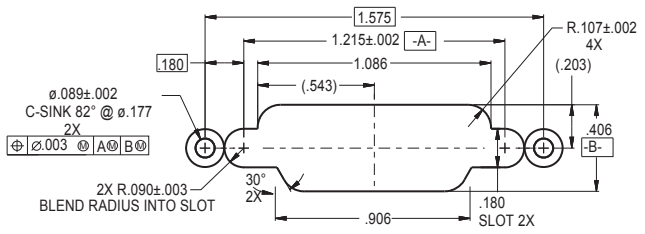

Shell Size G

Dimensions in Inches (millimeters) are subject to change without notice.

Series 79 Micro-Crimp Recommended Panel Cut-Outs

ALL CUTOUTS FOR .063" (.070 MAX) THICK PANEL MOUNTING

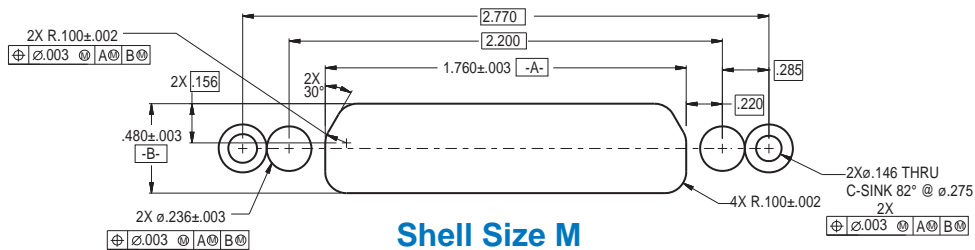
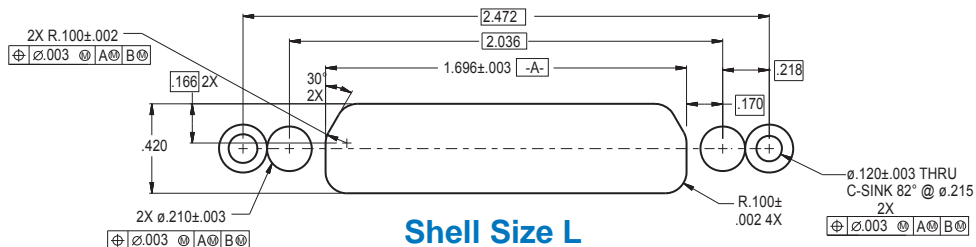
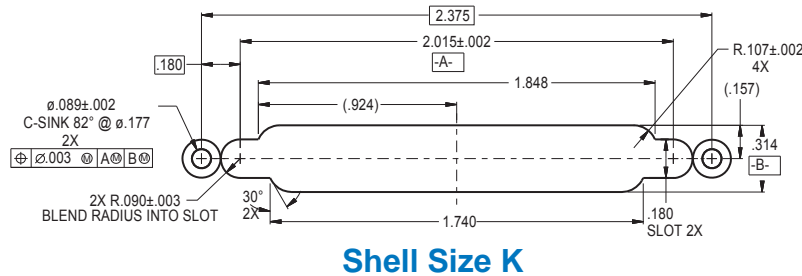
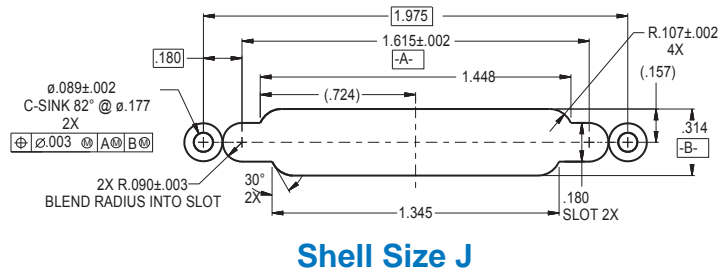
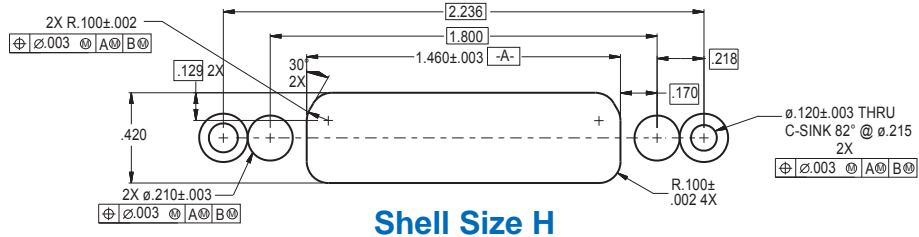

Dimensions in Inches (millimeters) are subject to change without notice.



SERIES 79

MICRO-CRIMP

CRIMP TERMINATED CABLE CONNECTORS



Today's aerospace and defense systems require advanced levels of environmental protection, electromagnetic shielding and size/weight reduction. The Series 79 Micro-Crimp features a precision D-shaped shell, ideal for high-density applications such as modular avionic boxes or low-profile tactical computers where traditional circular connectors cannot be used. Crimp terminated cable connectors are designed for I/O and wire-to-wire interconnections and feature machined aluminum shells, fluorosilicone face seals and wire grommets for environmental protection. Contacts are rear-release snap-in crimp type. Connectors are supplied with crimp contacts packaged separately. Size #23 signal pins accept up to #22 AWG wire. Size #16 contacts accept #16-18 AWG wire. Size #12 contacts accept #12-14 AWG wire. Size 12 and 16 cavities also accept coaxial contacts purchased separately. Connector shell features a groove for attachment of a low-profile EMI backshell adapter.



790-024P
Crimp Terminated Cable Receptacle Connector,
Pin Contacts
How To Order



790-024P Cable Receptacles
PIN CONTACTS WITH CRIMP TERMINATION

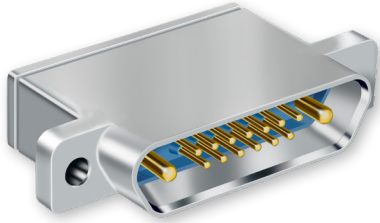

Rugged, lightweight 790-024P connectors feature machined aluminum shells, fluorosilicone face seals and wire grommets for environmental protection. Contacts are rear-release snap-in crimp type. Connectors are supplied with crimp contacts packaged separately. Size #23 signal pins accept up to #22 AWG wire. Size #16 contacts accept #16-18 AWG wire. Size #12 contacts accept #12-14 AWG wire. Size 12 and 16 cavities also accept coaxial contacts purchased separately. Connector shell features a groove for attachment of a low-profile EMI backshell adapter 799-015, ordered separately.

HOW TO ORDER

Sample Part Number			
790-024P	C-13	M	P
Base Part Number	Shell Size - Insert Arrangements	Shell Finish	Hardware Option
<p>790-024P Cable Receptacle with Pin Contacts</p>	<p>See Table 1 for Available Insert Arrangements.</p> <p>To order a connector without size #16 or #12 power pins, substitute "W" instead of "P" in the insert arrangement.</p> <p>Example:</p> <p>36P2 is supplied with 2 power pins.</p> <p>36W2 is supplied less the power pins.</p> <p>See Section B for coaxial contacts purchased separately.</p>	<p>M Electroless Nickel <i>general purpose applications</i></p> <p>MT Nickel-PTFE 1000 Hour Grey™ <i>maximum corrosion protection and durability (non-reflective grey)</i></p> <p>ZNU Zinc-Nickel with Black Chromate <i>tactical applications (non-reflective black)</i></p> <p>Additional shell finishes are listed on page C-9.</p>	<p>N Thru-Hole No Hardware</p> <p>L Low-Profile Captivated Jackscrew, Hex Head</p> <p>S Low-Profile Captivated Screwlock, Hex Head</p> <p>P Female Jackpost</p> <p>K Slot-Head Extended Jackscrew</p> <p>T Slot-Head Extended Captivated Screwlock</p>



SPECIFICATIONS

Current Rating	#23 5 AMPS, #16 13 A., #12 23 A.
Dielectric Withstanding Voltage	#23 500 VAC RMS, #12 and #16 1800 VAC RMS
Insulation Resistance	5000 megohms minimum
Operating Temperature	-65° C. to +150° C.
Shock	300 g.
Vibration	37 g.

MATERIALS AND FINISHES

Shell	Aluminum alloy
Contacts	Copper alloy, 50 microinches gold plated
Insulators	Liquid crystal polymer (LCP)
Retention Clips	Beryllium copper alloy
Interfacial Seal, Grommet	Fluorosilicone rubber
Hardware	300 series stainless steel

Dimensions in Inches (millimeters) are subject to change without notice.

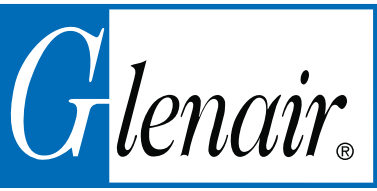

790-024P Crimp Terminated Cable Receptacle Connector, Pin Contacts How To Order

Table Contact Arrangements

Layout	Contact Quantity			Face View
	#23	#16	#12	
A-5	5			
B-2P2		2		
B-9	9			
C-13	13			
D-15	15			
D-3P3		3		
D-7P2	5	2		
E-11P2	9	2		
E-19	19			
E-7P3	4	3		
F-15P2	13	2		
F-23	23			
F-5P5		5		
G-33	33			
H-10P4	6	4		
H-29P7	22	7		
H-36P2	34	2		
H-54P2	52	2		
H-5P5		5		
H-66	66			
J-17P4	13	4		
J-25P2	23	2		
J-33	33			
J-7P7		7		
K-27P4	23	4		
K-35P2	33	2		
K-43	43			
K-9P9		9		
L-6P6		6		
L-78	78			
M-102	102			

CROSS-SECTIONAL VIEW OF 790-024P

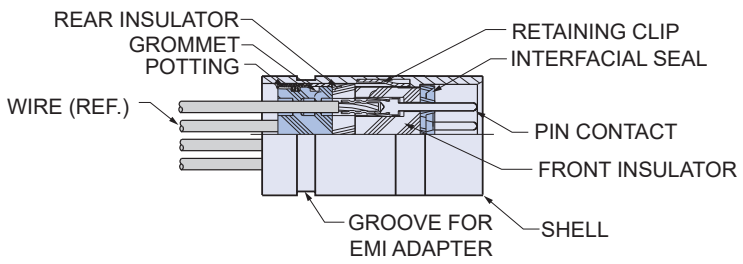

TABLE 2: HARDWARE OPTION

 N No Mating Hardware Connector is supplied with thru-holes. Shell size M have .171" (4.34) diameter, shell sizes H and L are .148" (3.76) diameter, other shell sizes are .092" (2.34) diameter. For loose hardware kits please consult the factory.	 P Jackposts Connector is supplied with removable jackposts. Shell size M have 6-32 UNC-2B thread, shell sizes H and L have #4-40 UNC thread, other sizes have #2-56 thread. Stainless steel.
 L Hex Head Jackscrews Connector is supplied with stainless steel non-removable low profile jackscrews. Shell size M have 6-32 UNC-2B thread, shell sizes H and L have #4-40 UNC thread, other sizes have #2-56 thread.	 K Extended Jackscrews Connector is supplied with stainless steel slot head non-removable jackscrews. Shell size M have 6-32 UNC-2B thread, shell sizes H and L have #4-40 UNC thread, other sizes have #2-56 thread.
 S Hex Head Screwlocks Connector is supplied with stainless steel non-removable low profile screwlocks. Shell size M have 6-32 UNC-2B thread, shell sizes H and L have #4-40 UNC thread, other sizes have #2-56 thread. Screwlocks allow the connector to be mated before the screws are fastened.	 T Extended Screwlocks Connector is supplied with stainless steel non-removable slot head screwlocks. Shell size M have 6-32 UNC-2B thread, shell sizes H and L have #4-40 UNC thread, other sizes have #2-56 thread. Screwlocks allow the connector to be mated before the screws are fastened.

Dimensions in Inches (millimeters) are subject to change without notice.

790-024P
Crimp Terminated Cable Receptacle Connector,
Pin Contacts
Dimensions



Series 79
 Cable
 Connectors

790-024P Cable Receptacle Dimensions

CRIMP TERMINATION

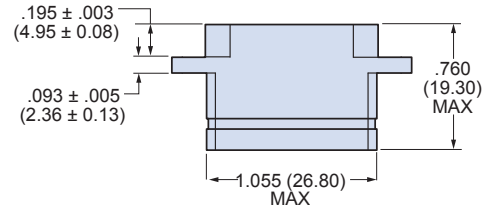
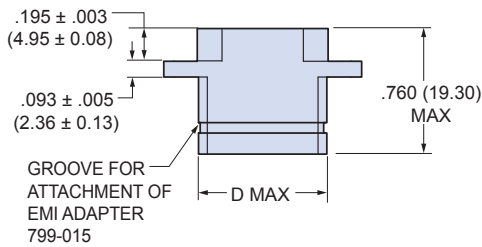
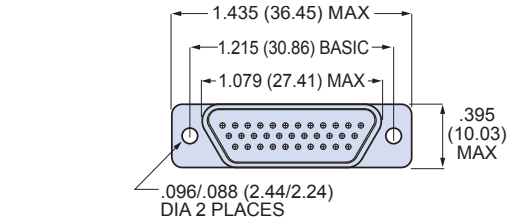
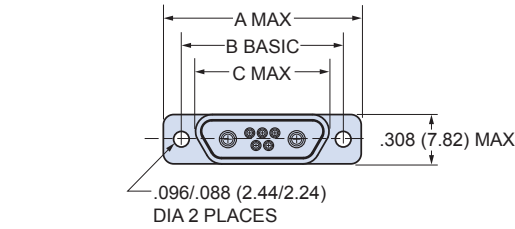

SHELL SIZE G

SHELL SIZES A, B, C, D, E, F, J, K

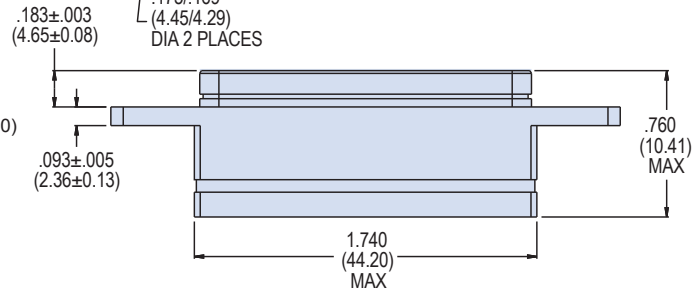
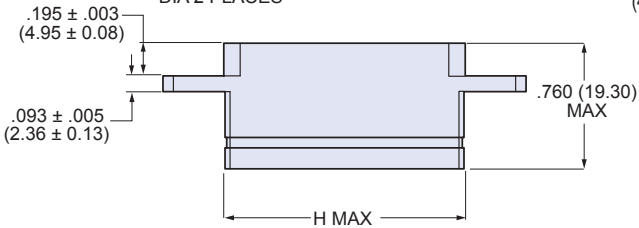
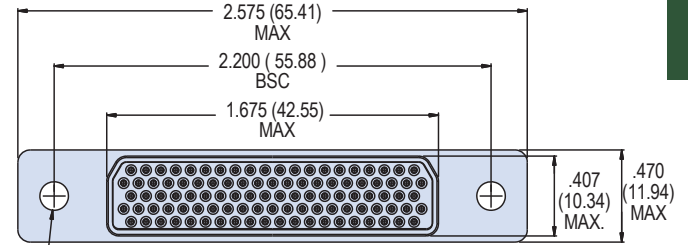
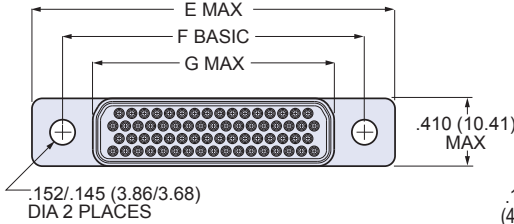

SHELL SIZE H AND L

SHELL SIZE M

790-024P DIMENSIONS																
Shell Size	A Max.		B Basic		C Max.		D Max.		E Max.		F Basic		G Max.		H Max.	
	In.	mm.	In.	mm.	In.	mm.	In.	mm.	In.	mm.	In.	mm.	In.	mm.	In.	mm.
A	.785	19.94	.565	14.35	.400	10.16	.390	9.91	—	—	—	—	—	—	—	—
B	.935	23.75	.715	18.16	.551	14.00	.540	13.72	—	—	—	—	—	—	—	—
C	1.085	27.65	.865	21.97	.701	17.81	.690	17.53	—	—	—	—	—	—	—	—
D	1.185	30.10	.965	24.51	.801	20.35	.790	20.07	—	—	—	—	—	—	—	—
E	1.335	33.91	1.115	28.32	.951	24.16	.940	23.88	—	—	—	—	—	—	—	—
F	1.485	37.72	1.265	32.13	1.101	27.96	1.090	27.69	—	—	—	—	—	—	—	—
H	—	—	—	—	—	—	—	—	2.175	55.25	1.800	45.72	1.450	36.83	1.440	36.58
J	1.845	46.86	1.615	41.02	1.460	37.08	1.450	36.83	—	—	—	—	—	—	—	—
K	2.240	56.90	2.015	51.18	1.860	47.24	1.840	46.74	—	—	—	—	—	—	—	—
L	—	—	—	—	—	—	—	—	2.420	61.47	2.036	51.71	1.686	42.82	1.675	42.55

Dimensions in Inches (millimeters) are subject to change without notice.



790-025S
Crimp Terminated Cable Plug Connector,
Socket Contacts
How To Order

790-025S Cable Plugs

SOCKET CONTACTS WITH CRIMP TERMINATION

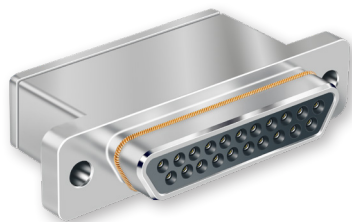

790-025S connectors feature machined aluminum shells and wire grommets for environmental protection. Contacts are rear-release snap-in crimp type. Connectors are supplied with crimp contacts packaged separately. Size #23 signal pins accept up to #22 AWG wire. Size #16 contacts accept #16-18 AWG wire. Size #12 contacts accept #12-14 AWG wire. Size 12 and 16 cavities also accept coaxial contacts purchased separately. Connector shell features a groove for attachment of a low-profile EMI adapter 799-015, ordered separately.

HOW TO ORDER

Sample Part Number

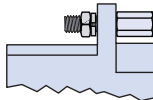
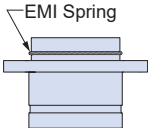
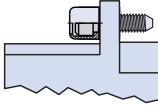
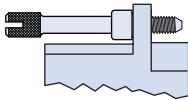
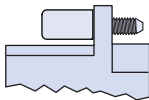
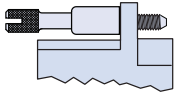
790-025S	H-5P5	E	M	S	
Part Number	Shell Size - Insert Arrangement	EMI Spring	Shell Finish	Hardware Option	
790-025S Cable Plug With Socket Contacts	See Table 1 for Available Insert Arrangements To order a connector without size #16 or #12 power pins, substitute "W" instead of "P" in the insert arrangement. Example: 36P2 is supplied with 2 power pins. 36W2 is supplied less the power pins. See Section B for coaxial contacts purchased separately.	E EMI Spring	M Electroless Nickel <i>general purpose applications</i>		
		N No Spring		N Thru-Hole No Hardware	P Female Jackpost
		 Note: EMI Spring is not compatible with chromate finishes including cadmium and zinc-nickel	MT Nickel-PTFE 1000 Hour Grey™ <i>maximum corrosion protection and durability (non-reflective grey)</i>		
		ZNU Zinc-Nickel with Black Chromate <i>tactical applications (non-reflective black)</i>	L Low-Profile Captivated Jackscrew, Hex Head		
			Additional shell finishes are listed on page C-9.	S Low-Profile Captivated Screwlock, Hex Head	T Slot-Head Extended Captivated Screwlock

SPECIFICATIONS

Current Rating	#23 5 AMPS, #16 13 A., #12 23 A.
Dielectric Withstanding Voltage	#23 500 VAC RMS, #12 and #16 1800 VAC RMS
Insulation Resistance	5000 megohms minimum
Operating Temperature	-65° C. to +150° C.
Shock	300 g.
Vibration	37 g.

MATERIALS AND FINISHES

Shell	Aluminum alloy
Contacts	Copper alloy, 50 microinches gold plated, stainless steel hood
Insulators	Liquid crystal polymer (LCP)
Retention Clips	Beryllium copper alloy
Grommet	Flourosilicone rubber
Hardware	300 series stainless steel

Dimensions in Inches (millimeters) are subject to change without notice.

790-025S Crimp Terminated Cable Plug Connector, Socket Contacts How To Order



Series 79
Cable
Connectors

Table Contact Arrangements

Layout	Contact Quantity			Face View
	#23	#16	#12	
A-5	5			
B-2P2	2	2		
B-9	9			
C-13	13			
D-15	15			
D-3P3	3	3		
D-7P2	5	2		
E-11P2	9	2		
E-19	19			
E-7P3	4	3		
F-15P2	13	2		
F-23	23			
F-5P5	5			
G-33	33			
H-10P4	6	4		
H-29P7	22	7		
H-36P2	34	2		
H-54P2	52	2		
H-5P5		5		
H-66	66			
J-17P4	13	4		
J-25P2	23	2		
J-33	33			
J-7P7		7		
K-27P4	23	4		
K-35P2	33	2		
K-43	43			
K-9P9		9		
L-6P6		6		
L-78	78			
M-102	102			

CROSS-SECTIONAL VIEW OF 790-025S

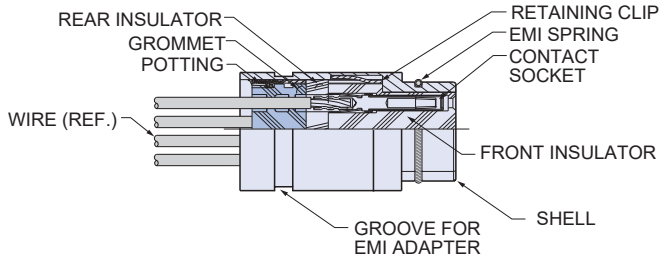
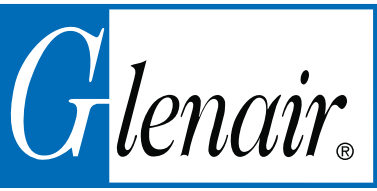

TABLE 2: HARDWARE OPTION

 N No Mating Hardware Connector is supplied with thru-holes. Shell size M have .171" (4.34) diameter, shell sizes H and L are .148" (3.76) diameter, other shell sizes are .092" (2.34) diameter. For loose hardware kits please consult the factory.	 P Jackposts Connector is supplied with removable jackposts. Shell size M have 6-32 UNC-2B thread, shell sizes H and L have #4-40 UNC thread, other sizes have #2-56 thread. Stainless steel.
 L Hex Head Jackscrews Connector is supplied with stainless steel non-removable low profile jackscrews. Shell size M have 6-32 UNC-2B thread, shell sizes H and L have #4-40 UNC thread, other sizes have #2-56 thread.	 K Extended Jackscrews Connector is supplied with stainless steel slot head non-removable jackscrews. Shell size M have 6-32 UNC-2B thread, shell sizes H and L have #4-40 UNC thread, other sizes have #2-56 thread.
 S Hex Head Screwlocks Connector is supplied with stainless steel non-removable low profile screwlocks. Shell size M have 6-32 UNC-2B thread, shell sizes H and L have #4-40 UNC thread, other sizes have #2-56 thread. Screwlocks allow the connector to be mated before the screws are fastened.	 T Extended Screwlocks Connector is supplied with stainless steel non-removable slot head screwlocks. Shell size M have 6-32 UNC-2B thread, shell sizes H and L have #4-40 UNC thread, other sizes have #2-56 thread. Screwlocks allow the connector to be mated before the screws are fastened.

Dimensions in Inches (millimeters) are subject to change without notice.

© 2014 Glenair, Inc. Series 79 Micro-Crimp U.S. CAGE Code 06324 Printed in U.S.A.



790-025S Crimp Terminated Cable Plug Connector, Socket Contacts Dimensions

790-025S Dimensions

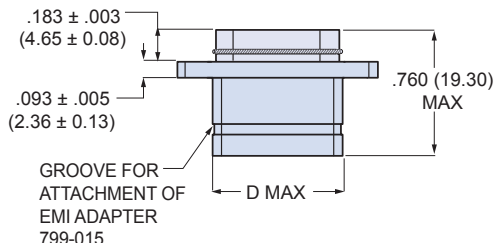
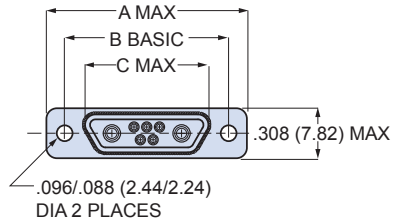

SHELL SIZES A, B, C, D, E, F, J, K

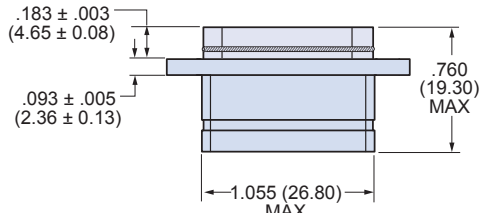
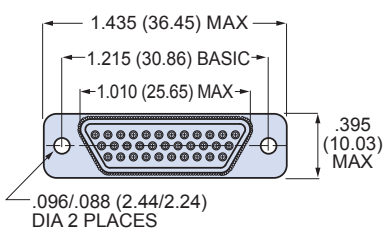

SHELL SIZE G

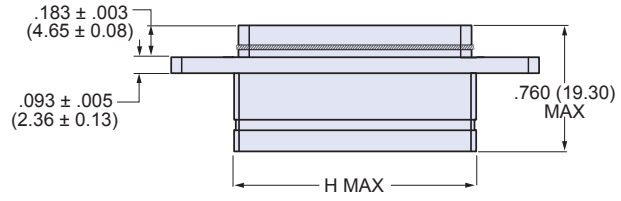
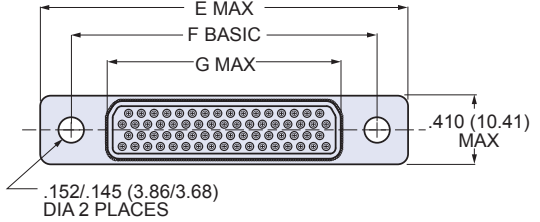

SHELL SIZE H AND L

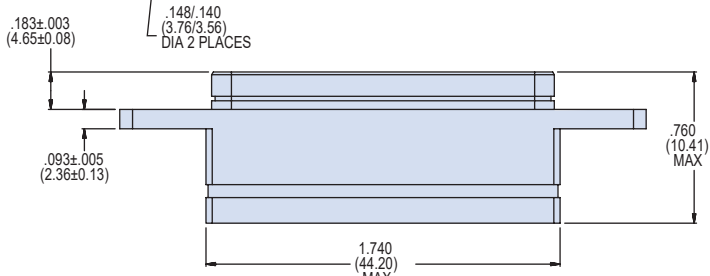
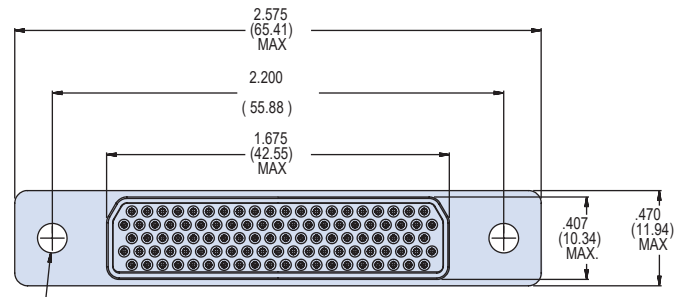

SHELL SIZE M

790-025S DIMENSIONS																
Shell Size	A Max.		B Basic		C Max.		D Max.		E Max.		F Basic		G Max.		H Max.	
	In.	mm.	In.	mm.	In.	mm.	In.	mm.	In.	mm.	In.	mm.	In.	mm.	In.	mm.
A	.785	19.94	.565	14.35	.335	8.51	.390	9.91	—	—	—	—	—	—	—	—
B	.935	23.75	.715	18.16	.485	12.32	.540	13.72	—	—	—	—	—	—	—	—
C	1.085	27.56	.865	21.97	.635	16.13	.690	17.53	—	—	—	—	—	—	—	—
D	1.185	30.10	.965	24.51	.735	18.67	.790	20.07	—	—	—	—	—	—	—	—
E	1.335	33.91	1.115	28.32	.885	22.48	.940	23.88	—	—	—	—	—	—	—	—
F	1.485	37.72	1.265	32.13	1.035	26.29	1.090	27.69	—	—	—	—	—	—	—	—
H	—	—	—	—	—	—	—	—	2.175	55.25	1.800	45.72	1.385	35.18	1.440	36.58
J	1.845	46.86	1.615	41.02	1.390	35.61	1.450	36.83	—	—	—	—	—	—	—	—
K	2.240	56.90	2.015	51.18	1.795	45.59	1.840	46.74	—	—	—	—	—	—	—	—
L	—	—	—	—	—	—	—	—	2.420	61.47	2.036	51.71	1.623	41.22	1.675	42.55

Dimensions in Inches (millimeters) are subject to change without notice.

790-069P
Solder Cup Cable Receptacle Connector,
Pin Contacts
How To Order



790-069P Cable Receptacles
SOLDER CUP PIN CONTACTS

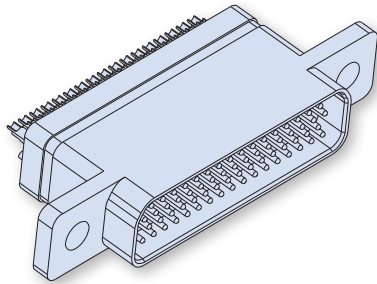

Rugged, lightweight 790-069P connectors feature machined aluminum shells, fluorosilicone face seals and wire grommets for environmental protection. Contacts are rear-release snap-in solder cup type. Connectors are supplied with solder cup contacts packaged separately. Size #23 signal pins accept up to #22 AWG wire. Size #16 contacts accept #16-18 AWG wire. Size #12 contacts accept #12-14 AWG wire. Size 12 and 16 cavities also accept coaxial contacts purchased separately. Connector shell features a groove for attachment of a low-profile EMI backshell adapter 799-015, ordered separately.

HOW TO ORDER

Sample Part Number			
790-069P	H-66	M	N
Base Part Number	Shell Size - Insert Arrangements	Shell Finish	Hardware Option
<p>790-069P Cable Receptacle with Solder Cup Pin Contacts</p>	<p>See Table 1 for Available Insert Arrangements.</p> <p>To order a connector without size #16 or #12 power pins, substitute "W" instead of "P" in the insert arrangement.</p> <p>Example:</p> <p>36P2 is supplied with 2 power pins.</p> <p>36W2 is supplied less the power pins.</p> <p>See Section B for coaxial contacts purchased separately.</p>	<p>M Electroless Nickel <i>general purpose applications</i></p> <p>MT Nickel-PTFE 1000 Hour Grey™ <i>maximum corrosion protection and durability (non-reflective grey)</i></p> <p>ZNU Zinc-Nickel with Black Chromate <i>tactical applications (non-reflective black)</i></p> <p>Additional shell finishes are listed on page C-9.</p>	<p>N Thru-Hole No Hardware</p> <p>L Low-Profile Captivated Jackscrew, Hex Head</p> <p>S Low-Profile Captivated Screwlock, Hex Head</p> <p>P Female Jackpost</p> <p>K Slot-Head Extended Jackscrew</p> <p>T Slot-Head Extended Captivated Screwlock</p>



SPECIFICATIONS

Current Rating	#23 5 AMPS, #16 13 A., #12 23 A.
Dielectric Withstanding Voltage	#23 500 VAC RMS, #12 and #16 1800 VAC RMS
Insulation Resistance	5000 megohms minimum
Operating Temperature	-65° C. to +150° C.
Shock	300 g.
Vibration	37 g.

MATERIALS AND FINISHES

Shell	Aluminum alloy
Contacts	Copper alloy, 50 microinches gold plated
Insulators	Liquid crystal polymer (LCP)
Retention Clips	Beryllium copper alloy
Interfacial Seal, Grommet	Fluorosilicone rubber
Hardware	300 series stainless steel

Dimensions in Inches (millimeters) are subject to change without notice.



790-069P Solder Cup Cable Receptacle Connector, Pin Contacts How To Order

Table Contact Arrangements

Layout	Contact Quantity	#23	#16	#12	Face View
A-5	5				
B-2P2	2				
B-9	9				
C-13	13				
D-15	15				
D-3P3	3				
D-7P2	5	2			
E-11P2	9	2			
E-19	19				
E-7P3	4	3			
F-15P2	13	2			
F-23	23				
F-5P5	5				
G-33	33				
H-10P4	6	4			
H-29P7	22	7			
H-36P2	34	2			
H-54P2	52	2			
H-5P5		5			
H-66	66				
J-17P4	13	4			
J-25P2	23	2			
J-33	33				
J-7P7	7				
K-27P4	23	4			
K-35P2	33	2			
K-43	43				
K-9P9	9				
L-6P6		6			
L-78	78				
M-102	102				

CROSS-SECTIONAL VIEW OF 790-069P

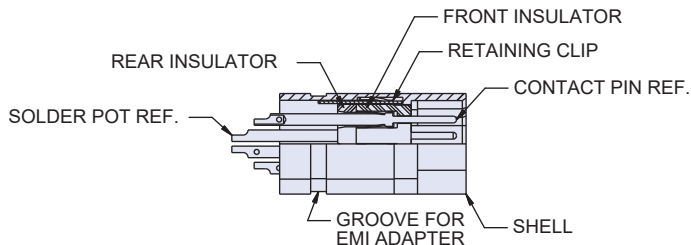

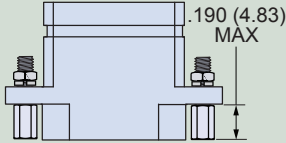
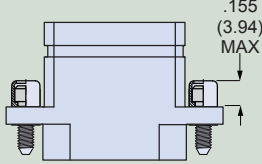
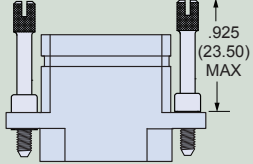
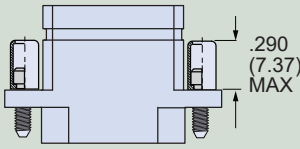
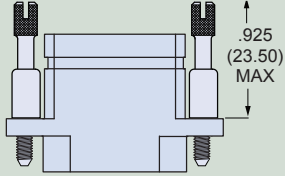

TABLE 2: HARDWARE OPTION

 <p>N</p> <p>No Mating Hardware</p> <p>Connector is supplied with thru-holes. Shell size M have .171" (4.34) diameter, shell sizes H and L are .148" (3.76) diameter, other shell sizes are .092" (2.34) diameter. For loose hardware kits please consult the factory.</p>	 <p>P</p> <p>Jackposts</p> <p>Connector is supplied with removable jackposts. Shell size M have 6-32 UNC-2B thread, shell sizes H and L have #4-40 UNC thread, other sizes have #2-56 thread. Stainless steel.</p>
 <p>L</p> <p>Hex Head Jackscrews</p> <p>Connector is supplied with stainless steel non-removable low profile jackscrews. Shell size M have 6-32 UNC-2B thread, shell sizes H and L have #4-40 UNC thread, other sizes have #2-56 thread.</p>	 <p>K</p> <p>Extended Jackscrews</p> <p>Connector is supplied with stainless steel slot head non-removable jackscrews. Shell size M have 6-32 UNC-2B thread, shell sizes H and L have #4-40 UNC thread, other sizes have #2-56 thread.</p>
 <p>S</p> <p>Hex Head Screwlocks</p> <p>Connector is supplied with stainless steel non-removable low profile screwlocks. Shell size M have 6-32 UNC-2B thread, shell sizes H and L have #4-40 UNC thread, other sizes have #2-56 thread. Screwlocks allow the connector to be mated before the screws are fastened.</p>	 <p>T</p> <p>Extended Screwlocks</p> <p>Connector is supplied with stainless steel non-removable slot head screwlocks. Shell size M have 6-32 UNC-2B thread, shell sizes H and L have #4-40 UNC thread, other sizes have #2-56 thread. Screwlocks allow the connector to be mated before the screws are fastened.</p>

Dimensions in Inches (millimeters) are subject to change without notice.

790-069P
Solder Cup Cable Receptacle Connector,
Pin Contacts
Dimensions



Series 79
 Cable
 Connectors

790-069P Cable Receptacle Dimensions

CRIMP TERMINATION

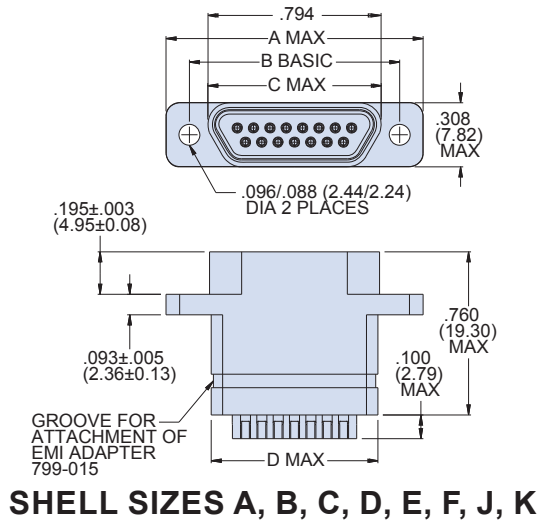

SHELL SIZES A, B, C, D, E, F, J, K

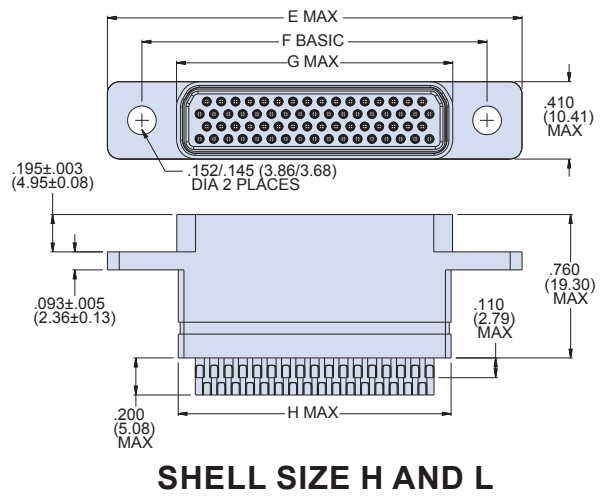

SHELL SIZE H AND L

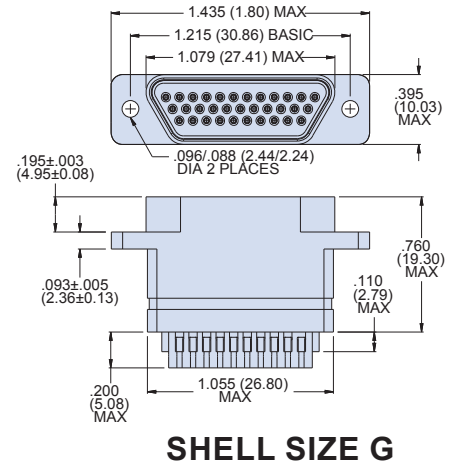

SHELL SIZE G

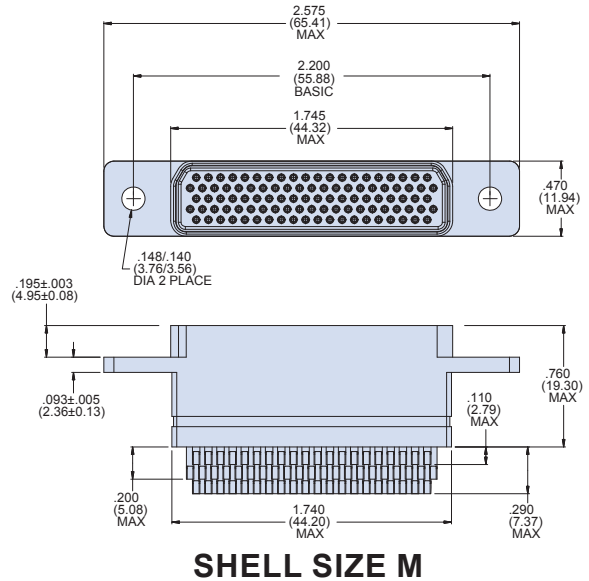

SHELL SIZE M

790-069P DIMENSIONS																
Shell Size	A Max.		B Basic		C Max.		D Max.		E Max.		F Basic		G Max.		H Max.	
	In.	mm.	In.	mm.	In.	mm.	In.	mm.	In.	mm.	In.	mm.	In.	mm.	In.	mm.
A	.785	19.94	.565	14.35	.400	10.16	.390	9.91	—	—	—	—	—	—	—	—
B	.935	23.75	.715	18.16	.551	14.00	.540	13.72	—	—	—	—	—	—	—	—
C	1.085	27.65	.865	21.97	.701	17.81	.690	17.53	—	—	—	—	—	—	—	—
D	1.185	30.10	.965	24.51	.801	20.35	.790	20.07	—	—	—	—	—	—	—	—
E	1.335	33.91	1.115	28.32	.951	24.16	.940	23.88	—	—	—	—	—	—	—	—
F	1.485	37.72	1.265	32.13	1.101	27.96	1.090	27.69	—	—	—	—	—	—	—	—
H	—	—	—	—	—	—	—	—	2.175	55.25	1.800	45.72	1.450	36.83	1.440	36.58
J	1.845	46.86	1.615	41.02	1.460	37.08	1.450	36.83	—	—	—	—	—	—	—	—
K	2.240	56.90	2.015	51.18	1.860	47.24	1.840	46.74	—	—	—	—	—	—	—	—
L	—	—	—	—	—	—	—	—	2.420	61.47	2.036	51.71	1.686	42.82	1.675	42.55

Dimensions in Inches (millimeters) are subject to change without notice.



790-070S
Solder Cup Cable Plug Connector,
Socket Contacts
How To Order

790-070S Cable Plugs
SOLDER CUP SOCKET CONTACTS

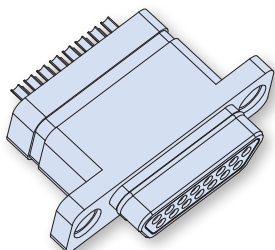

790-070S connectors feature machined aluminum shells and wire grommets for environmental protection. Contacts are rear-release snap-in solder cup type. Connectors are supplied with solder cup contacts packaged separately. Size #23 signal pins accept up to #22 AWG wire. Size #16 contacts accept #16-18 AWG wire. Size #12 contacts accept #12-14 AWG wire. Size 12 and 16 cavities also accept coaxial contacts purchased separately. Connector shell features a groove for attachment of a low-profile EMI adapter 799-015, ordered separately.

D

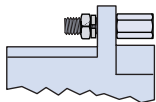
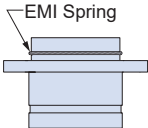
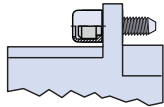
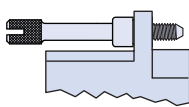
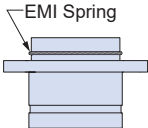
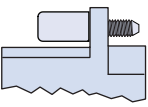
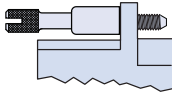
HOW TO ORDER					
Sample Part Number					
790-070S	H-66	E	M	N	
Part Number	Shell Size - Insert Arrangement	EMI Spring	Shell Finish	Hardware Option	
790-070S Cable Plug With Solder Cup Socket Contacts	See Table 1 for Available Insert Arrangements To order a connector without size #16 or #12 power pins, substitute "W" instead of "P" in the insert arrangement. Example: 36P2 is supplied with 2 power pins. 36W2 is supplied less the power pins. See Section B for coaxial contacts purchased separately.	E EMI Spring	M Electroless Nickel <i>general purpose applications</i>	 N Thru-Hole No Hardware	 P Female Jackpost
		N No Spring 	MT Nickel-PTFE <i>1000 Hour Grey™ maximum corrosion protection and durability (non-reflective grey)</i>	 L Low-Profile Captivated Jackscrew, Hex Head	 K Slot-Head Extended Jackscrew
		 Note: EMI Spring is not compatible with chromate finishes including cadmium and zinc-nickel	ZNU Zinc-Nickel with Black Chromate <i>tactical applications (non-reflective black)</i>	 S Low-Profile Captivated Screwlock, Hex Head	 T Slot-Head Extended Captivated Screwlock
Additional shell finishes are listed on page C-9.					

SPECIFICATIONS	
Current Rating	#23 5 AMPS, #16 13 A., #12 23 A.
Dielectric Withstanding Voltage	#23 500 VAC RMS, #12 and #16 1800 VAC RMS
Insulation Resistance	5000 megohms minimum
Operating Temperature	-65° C. to +150° C.
Shock	300 g.
Vibration	37 g.

MATERIALS AND FINISHES	
Shell	Aluminum alloy
Contacts	Copper alloy, 50 microinches gold plated, stainless steel hood
Insulators	Liquid crystal polymer (LCP)
Retention Clips	Beryllium copper alloy
Grommet	Flourosilicone rubber
Hardware	300 series stainless steel

Dimensions in Inches (millimeters) are subject to change without notice.

790-070S

Solder Cup Cable Plug Connector, Socket Contacts

How To Order



Table Contact Arrangements

Layout	Contact Quantity		Face View
	#23	#16#12	
A-5	5		
B-2P2	2		
B-9	9		
C-13	13		
D-15	15		
D-3P3	3		
D-7P2	5	2	
E-11P2	9	2	
E-19	19		
E-7P3	4	3	
F-15P2	13	2	
F-23	23		
F-5P5	5		
G-33	33		
H-10P4	6	4	
H-29P7	22	7	
H-36P2	34	2	
H-54P2	52	2	
H-5P5		5	
H-66	66		
J-17P4	13	4	
J-25P2	23	2	
J-33	33		
J-7P7	7		
K-27P4	23	4	
K-35P2	33	2	
K-43	43		
K-9P9	9		
L-6P6		6	
L-78	78		
M-102	102		

CROSS-SECTIONAL VIEW OF 790-070S

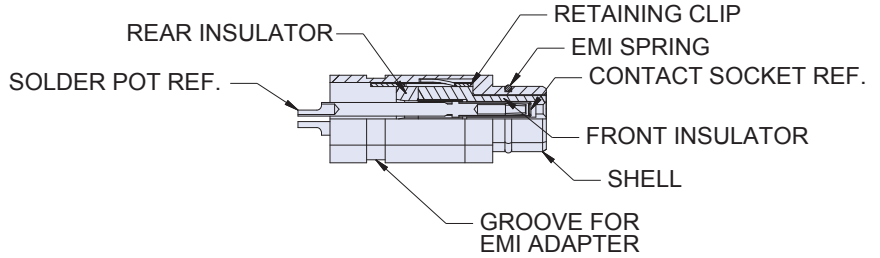
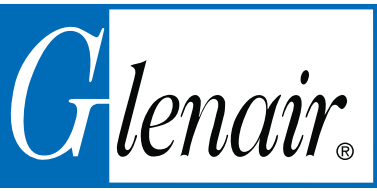

TABLE 2: HARDWARE OPTION

N No Mating Hardware	P Jackposts
 <p>Connector is supplied with thru-holes. Shell size M have .171" (4.34) diameter, shell sizes H and L are .148" (3.76) diameter, other shell sizes are .092" (2.34) diameter. For loose hardware kits please consult the factory.</p>	 <p>Connector is supplied with removable jackposts. Shell size M have 6-32 UNC-2B thread, shell sizes H and L have #4-40 UNC thread, other sizes have #2-56 thread. Stainless steel.</p>
 <p>Connector is supplied with stainless steel non-removable low profile jackscrews. Shell size M have 6-32 UNC-2B thread, shell sizes H and L have #4-40 UNC thread, other sizes have #2-56 thread.</p>	 <p>Connector is supplied with stainless steel slot head non-removable jackscrews. Shell size M have 6-32 UNC-2B thread, shell sizes H and L have #4-40 UNC thread, other sizes have #2-56 thread.</p>
 <p>Connector is supplied with stainless steel non-removable low profile screwlocks. Shell size M have 6-32 UNC-2B thread, shell sizes H and L have #4-40 UNC thread, other sizes have #2-56 thread. Screwlocks allow the connector to be mated before the screws are fastened.</p>	 <p>Connector is supplied with stainless steel non-removable slot head screwlocks. Shell size M have 6-32 UNC-2B thread, shell sizes H and L have #4-40 UNC thread, other sizes have #2-56 thread. Screwlocks allow the connector to be mated before the screws are fastened.</p>

Dimensions in Inches (millimeters) are subject to change without notice.



790-070S Solder Cup Cable Plug Connector, Socket Contacts Dimensions

790-070S Dimensions

D

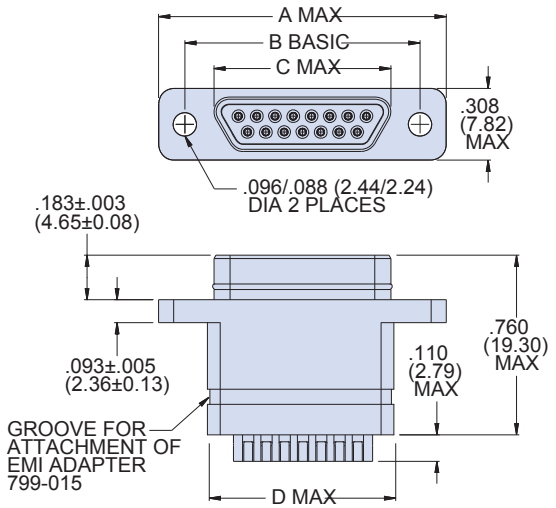

SHELL SIZES A, B, C, D, E, F, J, K

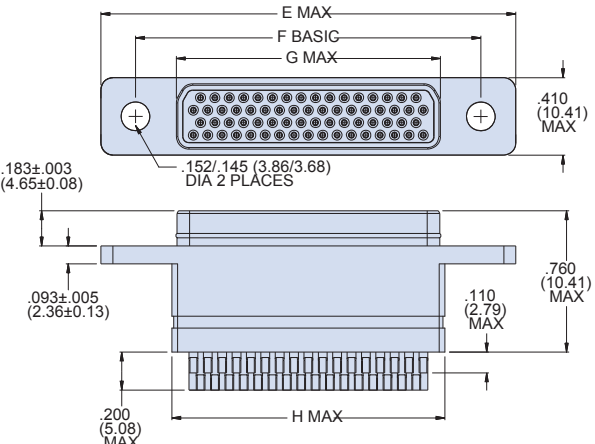

SHELL SIZE H AND L

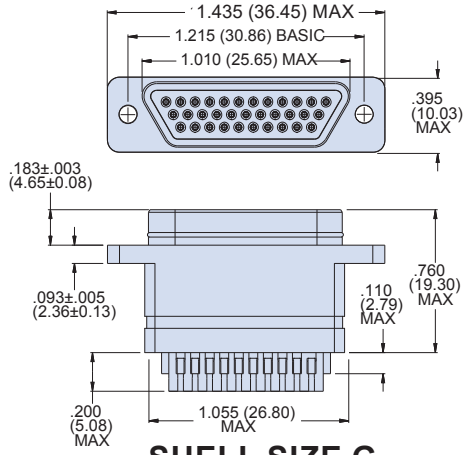

SHELL SIZE G

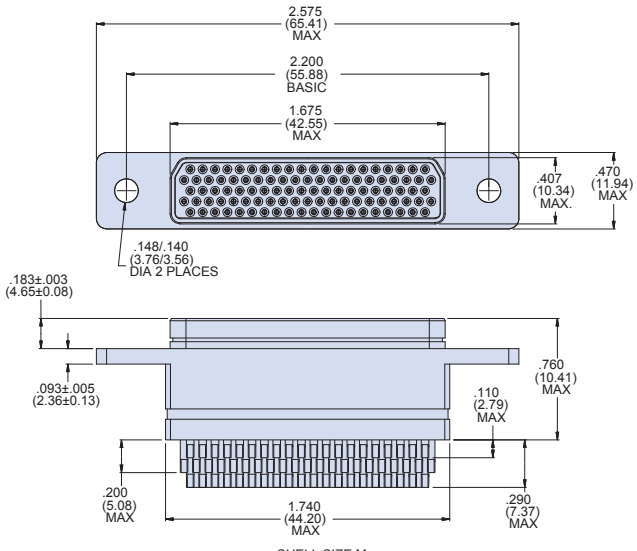

SHELL SIZE M

790-070S DIMENSIONS

Shell Size	A Max.		B Basic		C Max.		D Max.		E Max.		F Basic		G Max.		H Max.	
	In.	mm.	In.	mm.	In.	mm.	In.	mm.	In.	mm.	In.	mm.	In.	mm.	In.	mm.
A	.785	19.94	.565	14.35	.335	8.51	.390	9.91	—	—	—	—	—	—	—	—
B	.935	23.75	.715	18.16	.485	12.32	.540	13.72	—	—	—	—	—	—	—	—
C	1.085	27.56	.865	21.97	.635	16.13	.690	17.53	—	—	—	—	—	—	—	—
D	1.185	30.10	.965	24.51	.735	18.67	.790	20.07	—	—	—	—	—	—	—	—
E	1.335	33.91	1.115	28.32	.885	22.48	.940	23.88	—	—	—	—	—	—	—	—
F	1.485	37.72	1.265	32.13	1.035	26.29	1.090	27.69	—	—	—	—	—	—	—	—
H	—	—	—	—	—	—	—	—	2.175	55.25	1.800	45.72	1.385	35.18	1.440	36.58
J	1.845	46.86	1.615	41.02	1.390	35.61	1.450	36.83	—	—	—	—	—	—	—	—
K	2.240	56.90	2.015	51.18	1.795	45.59	1.840	46.74	—	—	—	—	—	—	—	—
L	—	—	—	—	—	—	—	—	2.420	61.47	2.036	51.71	1.623	41.22	1.675	42.55

Dimensions in Inches (millimeters) are subject to change without notice.

790-045P
Crimp Terminated Cable Receptacle Connector with
Integrated Banding Porch, Pin Contacts
How To Order



790-045P Cable Receptacles

CRIMP PIN CONTACTS, INTEGRATED BANDING PORCH

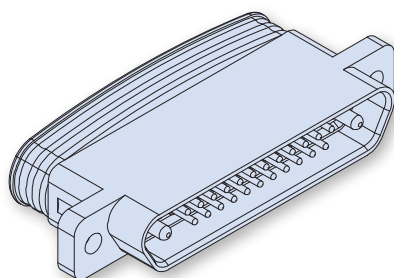

Rugged, lightweight 790-045P connectors feature machined aluminum shells, fluorosilicone face seals and wire grommets for environmental protection. Contacts are rear-release snap-in crimp. Connectors are supplied with crimp contacts packaged separately. Size #23 signal pins accept up to #22 AWG wire. Size #16 contacts accept #16-18 AWG wire. Size #12 contacts accept #12-14 AWG wire. Size 12 and 16 cavities also accept coaxial contacts purchased separately. Connector shell features an integrated banding porch for attachment of EMI shielding.

HOW TO ORDER			
Sample Part Number			
790-045P	H-10P4	M	B
Base Part Number	Shell Size - Insert Arrangements	Shell Finish	Mounting Hardware
790-045P Cable Receptacle with Crimp Pin Contacts and Integrated Banding Porch	See Table 1 for Available Insert Arrangements. To order a connector without size #16 or #12 power pins, substitute "W" instead of "P" in the insert arrangement. Example: 36P2 is supplied with 2 power pins. 36W2 is supplied less the power pins. See Section B for coaxial contacts purchased separately.	M Electroless Nickel <i>general purpose applications</i> MT Nickel-PTFE 1000 Hour Grey™ <i>maximum corrosion protection and durability (non-reflective grey)</i> ZNU Zinc-Nickel with Black Chromate <i>tactical applications (non-reflective black)</i> Additional shell finishes are listed on page C-9.	B Thru-Hole, No Hardware P Female Jackpost M Hex Socket Head, Jacking MF Hex Socket Head, Floating S Slotted Head, Jacking SF Slotted Head, Floating

SPECIFICATIONS	
Current Rating	#23 5 AMPS, #16 13 A., #12 23 A.
Dielectric Withstanding Voltage	#23 500 VAC RMS, #12 and #16 1800 VAC RMS
Insulation Resistance	5000 megohms minimum
Operating Temperature	-65° C. to +150° C.
Shock	300 g.
Vibration	37 g.

MATERIALS AND FINISHES	
Shell	Aluminum alloy
Contacts	Copper alloy, 50 microinches gold plated
Insulators	Liquid crystal polymer (LCP)
Retention Clips	Beryllium copper alloy
Interfacial Seal, Grommet	Flourosilicone rubber
Hardware	300 series stainless steel

Dimensions in Inches (millimeters) are subject to change without notice.



790-045P Crimp Terminated Cable Receptacle Connector with Integrated Banding Porch, Pin Contacts Dimensions

Table I Contact Arrangements

Layout	Contact Quantity	#23#16#12	Face View
A-5	5		
B-2P2	2		
B-9	9		
C-13	13		
D-15	15		
D-3P3	3		
D-7P2	5	2	
E-11P2	9	2	
E-19	19		
E-7P3	4	3	
F-15P2	13	2	
F-23	23		
F-5P5	5		
G-33	33		
H-10P4	6	4	
H-29P7	22	7	
H-36P2	34	2	
H-54P2	52	2	
H-5P5		5	
H-66	66		
J-17P4	13	4	
J-25P2	23	2	
J-33	33		
J-7P7	7		
K-27P4	23	4	
K-35P2	33	2	
K-43	43		
K-9P9	9		
L-6P6		6	
L-78	78		
M-102	102		

CROSS-SECTIONAL VIEW OF 790-045P

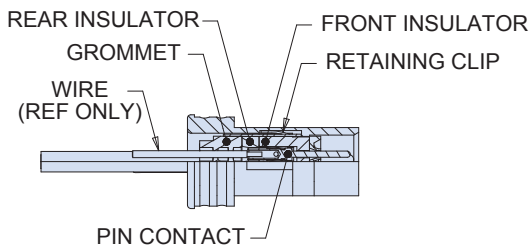

790-045P Dimensions

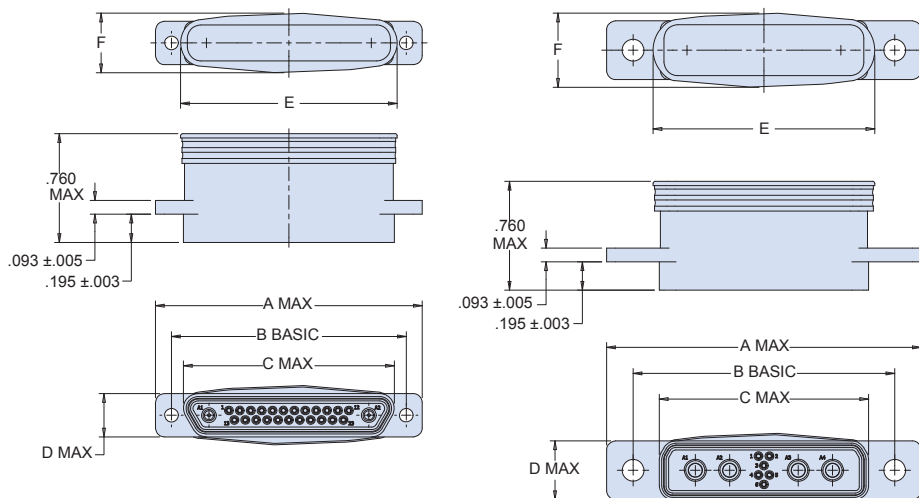

**SHELL SIZES A, B, C, D,
E, F, G, J, K**

SHELL SIZES H, L

790-045P DIMENSIONS

Shell Size	A Max.		B Basic		C Max.		D Max.		E Max.		F Max.	
	In.	mm.	In.	mm.	In.	mm.	In.	mm.	In.	mm.	In.	mm.
A	.785	19.94	.565	14.35	.400	10.16	.308	7.82	.440	11.18	.360	9.14
B	.935	23.75	.715	18.16	.551	14.00	.308	7.82	.590	14.99	.370	9.40
C	1.085	27.56	.865	21.97	.701	17.81	.308	7.82	.740	18.80	.390	9.91
D	1.185	30.10	.965	24.51	.801	20.35	.308	7.82	.840	21.34	.400	10.16
E	1.335	33.91	1.115	28.32	.951	24.16	.308	7.82	.990	25.15	.400	10.16
F	1.485	37.72	1.265	32.13	1.101	27.97	.308	7.82	1.140	28.96	.410	10.41
G	1.435	36.45	1.215	30.86	1.079	27.41	.395	10.03	1.130	28.70	.490	12.45
H	2.175	55.25	1.800	45.72	1.450	36.83	.410	10.41	1.525	38.74	.510	12.95
J	1.845	46.86	1.615	41.02	1.460	37.08	.308	7.82	1.490	37.85	.410	10.41
K	2.240	56.90	2.015	51.18	1.860	47.24	.308	7.82	1.890	48.01	.430	10.92
L	2.420	61.47	2.036	51.71	1.686	42.82	.410	10.41	1.760	44.70	.520	13.21
M	2.575	65.41	1.675	42.55	1.675	42.55	.470	11.94	1.850	46.99	.615	15.62

Dimensions in Inches (millimeters) are subject to change without notice.

790-046S
Crimp Terminated Cable Plug Connector with
Integrated Banding Porch, Socket Contacts
How To Order



790-046S Cable Receptacles

CRIMP SOCKET CONTACTS, INTEGRATED BANDING PORCH

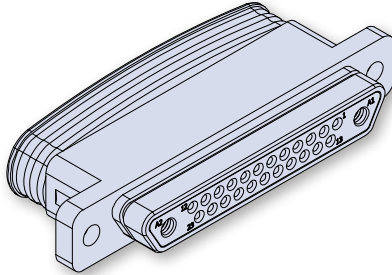

Rugged, lightweight 790-046S connectors feature machined aluminum shells, fluorosilicone face seals and wire grommets for environmental protection. Contacts are rear-release snap-in crimp. Connectors are supplied with crimp contacts packaged separately. Size #23 signal pins accept up to #22 AWG wire. Size #16 contacts accept #16-18 AWG wire. Size #12 contacts accept #12-14 AWG wire. Size 12 and 16 cavities also accept coaxial contacts purchased separately. Connector shell features an integrated banding porch for attachment of EMI shielding.

HOW TO ORDER

Sample Part Number

790-046S	H-10P4	E	M	B
Base Part Number	Shell Size - Insert Arrangements	Ground Spring Option	Shell Finish	Mounting Hardware
790-046S Cable Receptacle with Crimp Socket Contacts and Integrated Banding Porch	See Table 1 for Available Insert Arrangements. To order a connector without size #16 or #12 power pins, substitute "W" instead of "P" in the insert arrangement. Example: 36P2 is supplied with 2 power pins. 36W2 is supplied less the power pins. See Section B for coaxial contacts purchased separately.	E EMI Ground Spring Supplied N Not Supplied	M Electroless Nickel <i>general purpose applications</i> MT Nickel-PTFE 1000 Hour Grey™ <i>maximum corrosion protection and durability (non-reflective grey)</i> ZNU Zinc-Nickel with Black Chromate <i>tactical applications (non-reflective black)</i> Additional shell finishes are listed on page C-9.	B Thru-Hole, No Hardware P Female Jackpost M Hex Socket Head, Jacking MF Hex Socket Head, Floating S Slotted Head, Jacking SF Slotted Head, Floating



SPECIFICATIONS

Current Rating	#23 5 AMPS, #16 13 A., #12 23 A.
Dielectric Withstanding Voltage	#23 500 VAC RMS, #12 and #16 1800 VAC RMS
Insulation Resistance	5000 megohms minimum
Operating Temperature	-65° C. to +150° C.
Shock	300 g.
Vibration	37 g.

MATERIALS AND FINISHES

Shell	Aluminum alloy
Contacts	Copper alloy, 50 microinches gold plated
Insulators	Liquid crystal polymer (LCP)
Retention Clips	Beryllium copper alloy
Interfacial Seal, Grommet	Fluorosilicone rubber
Hardware	300 series stainless steel

Dimensions in Inches (millimeters) are subject to change without notice.

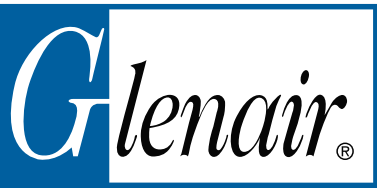

790-046S Crimp Terminated Cable Plug Connector with Integrated Banding Porch, Socket Contacts Dimensions

Table Contact Arrangements

Layout	Contact Quantity			Face View
	#23	#16	#12	
A-5	5			
B-2P2		2		
B-9	9			
C-13	13			
D-15	15			
D-3P3		3		
D-7P2	5	2		
E-11P2	9	2		
E-19	19			
E-7P3	4	3		
F-15P2	13	2		
F-23	23			
F-5P5		5		
G-33	33			
H-10P4	6		4	
H-29P7	22		7	
H-36P2	34		2	
H-54P2	52		2	
H-5P5			5	
H-66	66			
J-17P4	13		4	
J-25P2	23		2	
J-33	33			
J-7P7			7	
K-27P4	23		4	
K-35P2	33		2	
K-43	43			
K-9P9			9	
L-6P6			6	
L-78	78			
M-102	102			

CROSS-SECTIONAL VIEW OF 790-046S

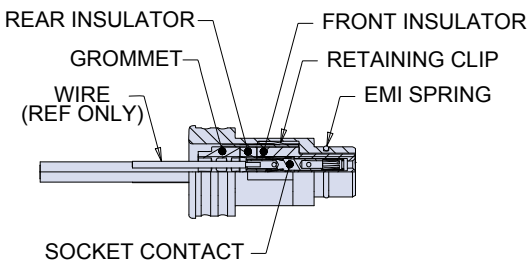

790-046S Dimensions

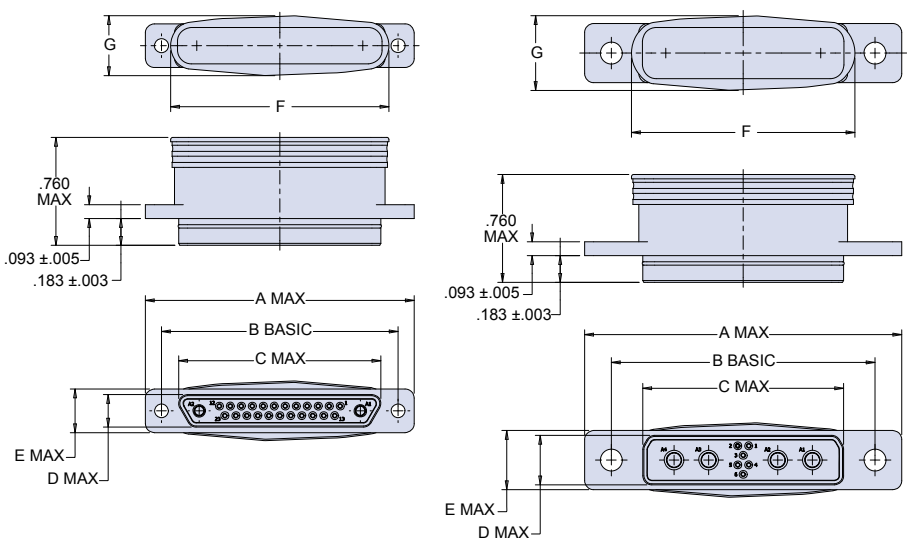

SHELL SIZES A, B, C, D, E, F, G, J, K

SHELL SIZES H, L

790-046S DIMENSIONS

Shell Size	A Max.		B Basic		C Max.		D Max.		E Max.		F Max.		G Max.	
	In.	mm.	In.	mm.	In.	mm.	In.	mm.	In.	mm.	In.	mm.	In.	mm.
A	.785	19.94	.565	14.35	.335	8.51	.233	5.92	.308	7.82	.440	11.18	.360	9.14
B	.935	23.75	.715	18.16	.485	12.32	.233	5.92	.308	7.82	.590	14.99	.370	9.40
C	1.085	27.56	.865	21.97	.635	16.13	.233	5.92	.308	7.82	.740	18.80	.390	9.91
D	1.185	30.10	.965	24.51	.735	18.67	.233	5.92	.308	7.82	.840	21.34	.400	10.16
E	1.335	33.91	1.115	28.32	.885	22.48	.233	5.92	.308	7.82	.990	25.15	.400	10.16
F	1.485	37.72	1.265	32.13	1.035	26.29	.233	5.92	.308	7.82	1.140	28.96	.410	10.41
G	1.435	36.45	1.215	30.86	1.010	25.65	.320	8.13	.395	10.03	1.130	28.70	.490	12.45
H	2.175	55.25	1.800	45.72	1.385	35.18	.349	8.86	.410	10.41	1.525	38.74	.510	12.95
J	1.845	46.86	1.615	41.02	1.390	35.31	.233	5.92	.308	7.82	1.490	37.85	.410	10.41
K	2.240	56.90	2.015	51.18	1.795	45.59	.233	5.92	.308	7.82	1.890	48.01	.430	10.92
L	2.420	61.47	2.036	51.71	1.623	41.22	.349	8.86	.410	10.41	1.760	44.70	.520	13.21
M	2.575	65.41	2.200	55.88	1.745	44.32	.407	10.34	.470	11.94	1.850	46.99	.615	15.62

Dimensions in Inches (millimeters) are subject to change without notice.

790-026P
Crimp Terminated Panel Mount Receptacles,
Pin Contacts
How To Order



790-026P Panel Mount Receptacles
PIN CONTACTS WITH CRIMP TERMINATION

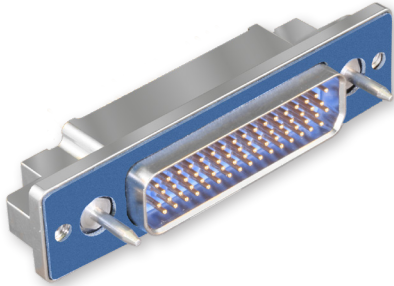

790-026P connectors are designed for rear-panel mounting and are supplied with conductive panel gaskets. These connectors feature machined aluminum shells, fluorosilicone face seals and wire grommets for environmental protection. Contacts are rear-release snap-in crimp type. Connectors are supplied with crimp contacts packaged separately. Size #23 signal pins accept up to #22 AWG wire. Size #16 contacts accept #16-18 AWG wire. Size #12 contacts accept #12-14 AWG wire. Size 12 and 16 cavities also accept coaxial contacts purchased separately. Attach optional shielding adapters (799-016) for EMI protection.

HOW TO ORDER

Sample Part Number

790-026P

L-6P6

MT

G

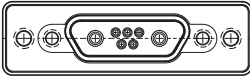
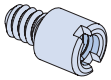
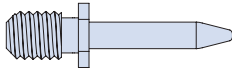
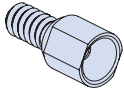
Part Number	Shell Size - Insert Arrangement	Shell Finish	Hardware Option	
790-026P Rear Panel Mounted Receptacle with Pin Contacts	See Table 1 for Available Insert Arrangements To order a connector without size #16 or #12 power pins, substitute "W" instead of "P" in the insert arrangement. Example: 36P2 is supplied with 2 power pins. 36W2 is supplied less the power pins. See Section B for coaxial contacts purchased separately.	M Electroless Nickel <i>general purpose applications</i> MT Nickel-PTFE <i>1000 Hour Grey™</i> <i>maximum corrosion protection and durability</i> <i>(non-reflective grey)</i> ZNU Zinc-Nickel with Black Chromate <i>tactical applications</i> <i>(non-reflective black)</i> Additional shell finishes are listed on page C-9.	 N No Hardware	 P Female Jackpost
			 G Guide Pin	 S Female Guide Socket

SPECIFICATIONS

Current Rating	#23 5 AMPS, #16 13 A., #12 23 A.
Dielectric Withstanding Voltage	#23 500 VAC RMS, #12 and #16 1800 VAC RMS
Insulation Resistance	5000 megohms minimum
Operating Temperature	-65° C. to +150° C.
Shock	300 g.
Vibration	37 g.

MATERIALS AND FINISHES

Shell	Aluminum alloy
Contacts	Copper alloy, 50 microinches gold plated
Insulators	Liquid crystal polymer (LCP)
Retention Clips	Beryllium copper alloy
Interfacial Seal, Grommet	Flourosilicone rubber
Hardware	300 series stainless steel
Panel Gasket	Fluorosilicone, conductive

Dimensions in Inches (millimeters) are subject to change without notice.



790-026P Crimp Terminated Panel Mount Receptacles, Pin Contacts How To Order

Table 1 Contact Arrangements

Layout	Contact Quantity		Face View
	#23	#16#12	
A-5	5		
B-2P2	2		
B-9	9		
C-13	13		
D-15	15		
D-3P3	3		
D-7P2	5	2	
E-11P2	9	2	
E-19	19		
E-7P3	4	3	
F-15P2	13	2	
F-23	23		
F-5P5	5		
G-33	33		
H-10P4	6	4	
H-29P7	22	7	
H-36P2	34	2	
H-54P2	52	2	
H-5P5		5	
H-66	66		
J-17P4	13	4	
J-25P2	23	2	
J-33	33		
J-7P7	7		
K-27P4	23	4	
K-35P2	33	2	
K-43	43		
K-9P9	9		
L-6P6		6	
L-78	78		
M-102	102		

CROSS-SECTIONAL VIEW OF 790-026P

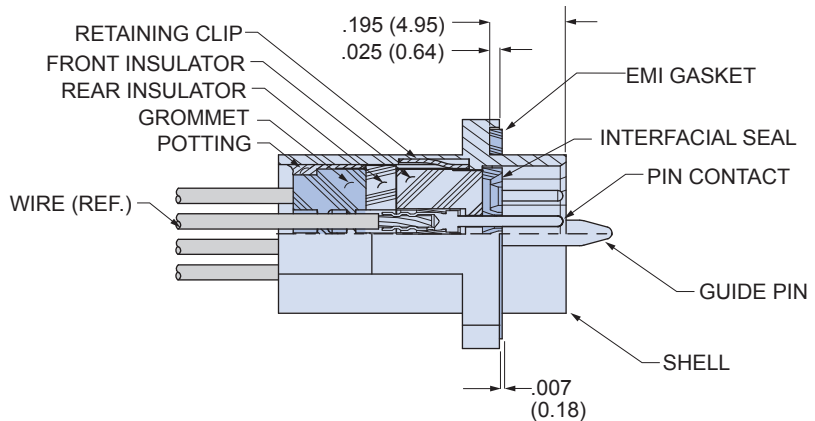
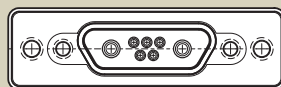

TABLE 2 HARDWARE OPTION



N

No Mating Hardware

Connector is supplied with threaded holes. Shell size M has #8-32 threads, shell sizes H and L have #6-32 threads, other sizes have #4-40 threads. Thread depth is .150" (3.8).

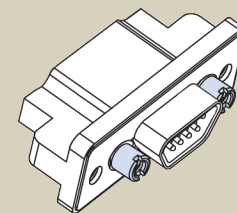

P

Jackposts

Connector is supplied with non-removable stainless steel jackposts. Shell size M has #6-32 threads, shell sizes H and L have #4-40 UNC thread, other sizes have #2-56 thread. Stainless steel.

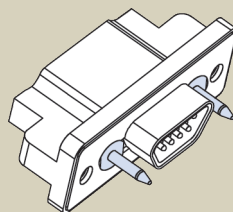

G

Guide Pins

Connector is supplied with stainless steel non-removable guide pins. Mates with type "S" guide sockets on corresponding plug connector.

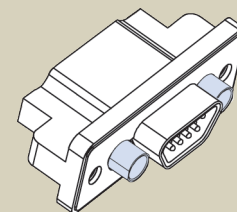

S

Guide Sockets

Connector is supplied with stainless steel non-removable bushings. Mates with type "G" guide pins on corresponding plug connector.

Dimensions in Inches (millimeters) are subject to change without notice.

790-026P
Crimp Terminated Panel Mount Receptacles,
Pin Contacts
Dimensions



790-026P Shell Size A, B, C, D, E, F, J, K Dimensions

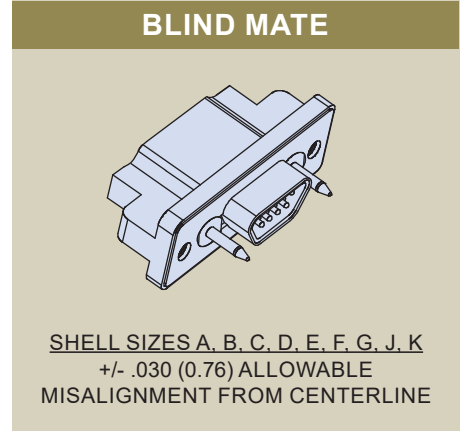
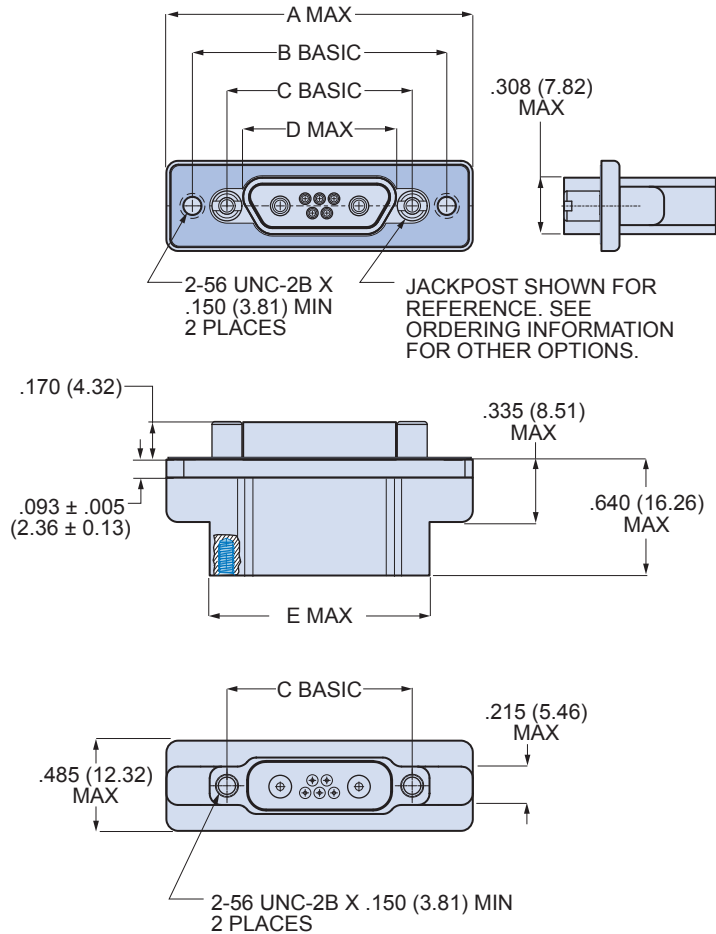

790-026P Dimensions for Size A-F, J and K										
Shell Size	A Max.		B Basic		C Basic		D Max.		E Max.	
	In.	mm.	In.	mm.	In.	mm.	In.	mm.	In.	mm.
A	1.211	30.76	.925	23.50	.565	14.35	.401	10.19	.760	19.30
B	1.361	34.57	1.075	27.31	.715	18.16	.551	14.00	.910	21.11
C	1.511	38.38	1.225	31.12	.865	21.97	.701	17.81	1.060	26.92
D	1.611	40.92	1.325	33.66	.965	24.51	.801	20.35	1.160	29.46
E	1.761	44.73	1.475	37.47	1.115	28.32	.951	24.16	1.310	33.27
F	1.911	48.54	1.625	41.28	1.265	32.13	1.101	27.96	1.460	37.08
J	2.261	57.43	1.975	50.17	1.615	41.02	1.460	37.08	1.810	45.97
K	2.661	67.59	2.375	60.33	2.015	51.18	1.860	47.24	2.210	56.13

Dimensions in Inches (millimeters) are subject to change without notice.



790-026P Crimp Terminated Panel Mount Receptacles, Pin Contacts Dimensions

790-026P Shell Size G Dimensions

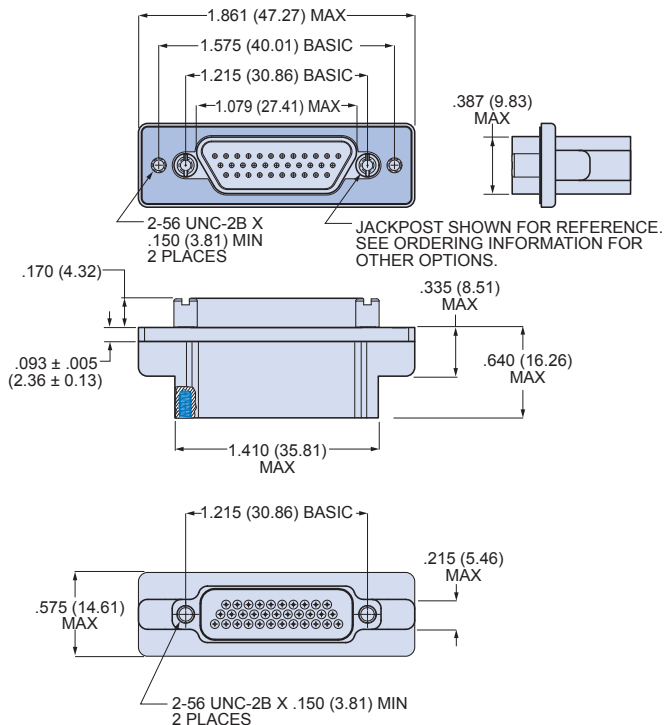

BLIND MATE

SHELL SIZES A, B, C, D, E, F, G, J, K
+/- .030 (0.76) ALLOWABLE
MISALIGNMENT FROM
CENTERLINE

790-026P Shell Size H and L Dimensions

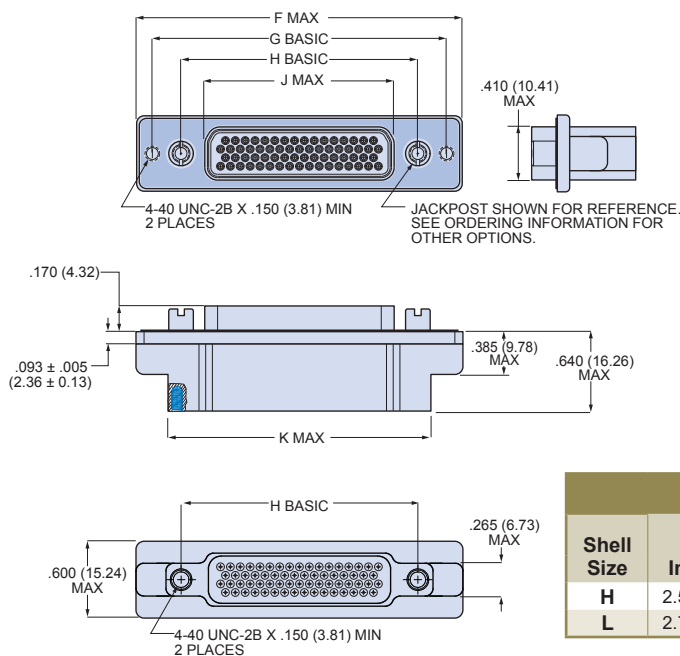

BLIND MATE

SHELL SIZES H, L
+/- .040 (1.02) ALLOWABLE
MISALIGNMENT
FROM CENTERLINE

790-026P SIZE H & L DIMENSIONS

Shell Size	F Max.		G Basic		H Basic		J Max.		K Max.	
	In.	mm.	In.	mm.	In.	mm.	In.	mm.	In.	mm.
H	2.500	63.50	2.236	56.79	1.800	45.72	1.450	36.83	2.045	51.94
L	2.736	69.49	2.472	62.79	2.036	51.71	1.686	42.82	2.281	57.94

Dimensions in Inches (millimeters) are subject to change without notice.

790-026P
Crimp Terminated Panel Mount Receptacles,
Pin Contacts
Dimensions



790-026P Shell Size M Dimensions

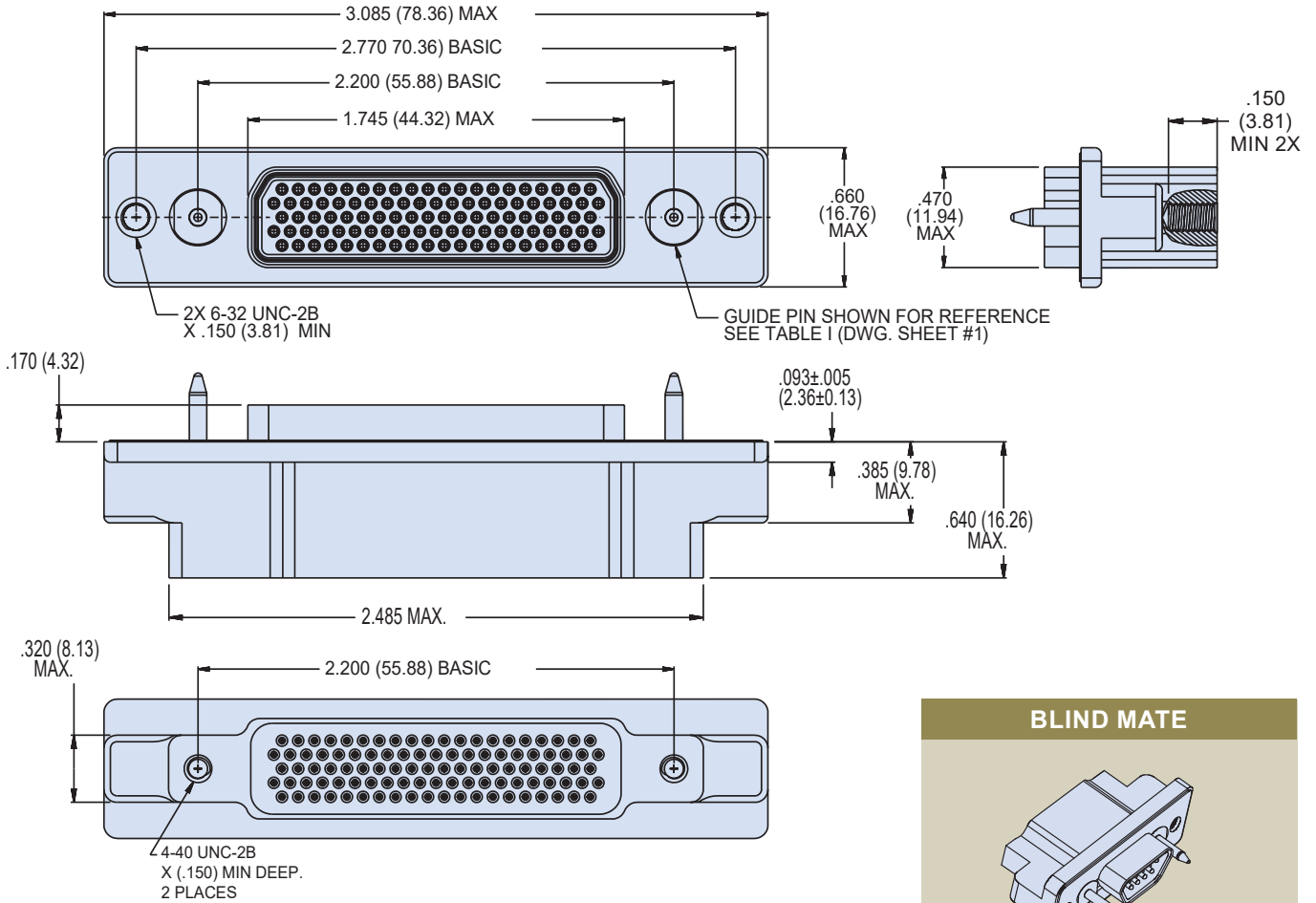

BLIND MATE

SHELL SIZE M
 +/- .050 (0.76) ALLOWABLE MISALIGNMENT FROM CENTERLINE



Dimensions in Inches (millimeters) are subject to change without notice.



790-027S
Crimp Terminated Panel Mount Plugs,
Socket Contacts
How To Order

790-027S Panel Mount Plugs

SOCKET CONTACTS WITH CRIMP TERMINATION



790-027S connectors are designed for rear-panel mounting and are supplied with conductive panel gaskets. These connectors feature machined aluminum shells and wire grommets for environmental protection. Contacts are rear-release snap-in crimp type. Connectors are supplied with crimp contacts packaged separately. Size #23 signal pins accept up to #22 AWG wire. Size #16 contacts accept #16-18 AWG wire. Size #12 contacts accept #12-14 AWG wire. Size 12 and 16 cavities also accept coaxial contacts purchased separately. Attach optional shielding adapters (799-016) for EMI protection.

HOW TO ORDER

Sample Part Number

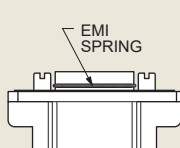
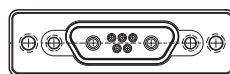
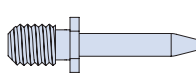
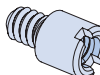
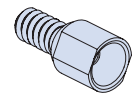
790-027S	H-66	M	E	P
Part Number	Shell Size - Insert Arr.	Shell Finish	EMI Spring	Hardware Option
790-027S Rear Panel Mounted Plug with Socket Contacts	See Table 1 for Available Insert Arrangements To order a connector without size #16 or #12 power pins, substitute "W" instead of "P" in the insert arrangement. Example: 36P2 is supplied with 2 power pins. 36W2 is supplied less the power pins. See Section B for coaxial contacts purchased separately.	M Electroless Nickel <i>general purpose applications</i> MT Nickel-PTFE 1000 Hour Grey™ <i>maximum corrosion protection and durability (non-reflective grey)</i> ZNU Zinc-Nickel with Black Chromate <i>tactical applications (non-reflective black)</i> Additional shell finishes are listed on page C-9.	E EMI Spring N No Spring  Note: EMI Spring is not compatible with chromate finishes including cadmium and zinc-nickel	 N No Hardware  G Guide Pin  P Female Jackpost  S Female Guide Socket

SPECIFICATIONS

Current Rating	#23 5 AMPS, #16 13 A., #12 23 A.
Dielectric Withstanding Voltage	#23 500 VAC RMS, #12 and #16 1800 VAC RMS
Insulation Resistance	5000 megohms minimum
Operating Temperature	-65° C. to +150° C.
Shock	300 g.
Vibration	37 g.

MATERIALS AND FINISHES

Shell	Aluminum alloy
Contacts	Copper alloy, 50 microinches gold plated, stainless steel hood
Insulators	Liquid crystal polymer (LCP)
Retention Clips	Beryllium copper alloy
Grommet	Fluorosilicone rubber
Hardware	300 series stainless steel
Panel Gasket	Fluorosilicone, conductive

Dimensions in Inches (millimeters) are subject to change without notice.

790-027S Crimp Terminated Panel Mount Plugs, Socket Contacts How To Order



Table 1 Contact Arrangements

Layout	Contact Quantity	#23#16#12	Face View
A-5	5		
B-2P2	2		
B-9	9		
C-13	13		
D-15	15		
D-3P3	3		
D-7P2	5	2	
E-11P2	9	2	
E-19	19		
E-7P3	4	3	
F-15P2	13	2	
F-23	23		
F-5P5	5		
G-33	33		
H-10P4	6	4	
H-29P7	22	7	
H-36P2	34	2	
H-54P2	52	2	
H-5P5		5	
H-66	66		
J-17P4	13	4	
J-25P2	23	2	
J-33	33		
J-7P7		7	
K-27P4	23	4	
K-35P2	33	2	
K-43	43		
K-9P9		9	
L-6P6		6	
L-78	78		
M-102	102		

CROSS-SECTIONAL VIEW OF 790-027S

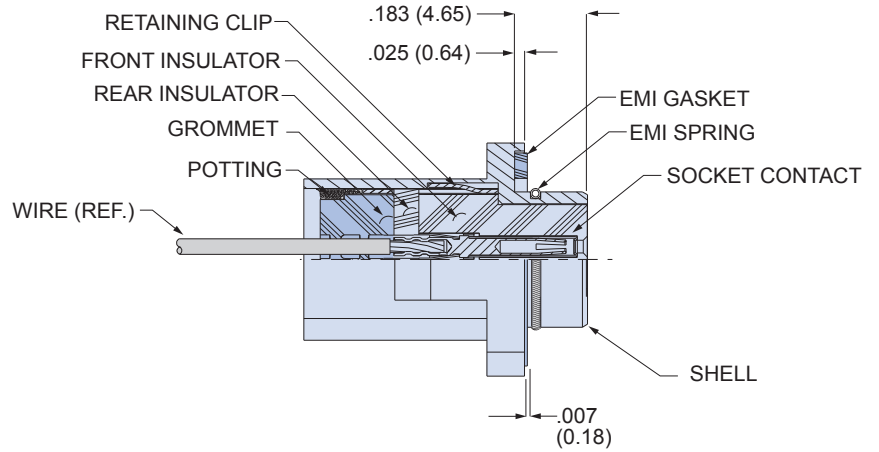

TABLE 2 HARDWARE OPTION

<p>N No Mating Hardware</p> <p>Connector is supplied with threaded holes. Shell size M has #8-32 threads, shell sizes H and L have #6-32 threads, other sizes have #4-40 threads. Thread depth is .150" (3.8).</p>	<p>P Jackposts</p> <p>Connector is supplied with non-removable stainless steel jackposts. Shell size M has #6-32 threads, shell sizes H and L have #4-40 UNC thread, other sizes have #2-56 thread. Stainless steel.</p>
<p>G Guide Pins</p> <p>Connector is supplied with stainless steel non-removable guide pins. Mates with type "S" guide sockets on corresponding receptacle connector.</p>	<p>S Guide Sockets</p> <p>Connector is supplied with stainless steel non-removable bushings. Mates with type "G" guide pins on corresponding receptacle connector.</p>

Dimensions in Inches (millimeters) are subject to change without notice.





790-027S
Crimp Terminated Panel Mount Plugs,
Socket Contacts
Dimensions

790-027S Shell Size A, B, C, D, E, F, J and K Dimensions

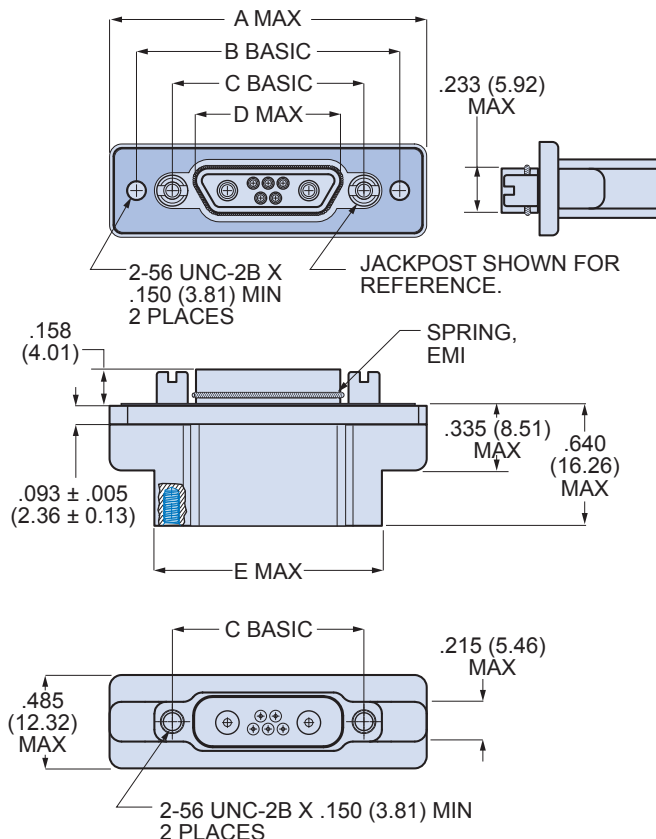

BLIND MATE

SHELL SIZES A, B, C, D, E, F, G, J, K
+/- .030 (0.76) ALLOWABLE
MISALIGNMENT FROM CENTERLINE

790-027S Shell Size A-F, J and K Dimensions

790-027S SIZE A-F, J, K DIMENSIONS										
Shell Size	A Max.		B Basic		C Basic		D Max.		E Max.	
	In.	mm.	In.	mm.	In.	mm.	In.	mm.	In.	mm.
A	1.211	30.76	.925	23.50	.565	14.35	.335	8.51	.760	19.30
B	1.361	34.57	1.075	27.31	.715	18.16	.485	12.32	.910	21.11
C	1.511	38.38	1.225	31.12	.865	21.97	.635	16.13	1.060	26.92
D	1.611	40.92	1.325	33.66	.965	24.51	.735	18.67	1.160	29.46
E	1.761	44.73	1.475	37.47	1.115	28.32	.885	22.48	1.310	33.27
F	1.911	48.54	1.625	41.28	1.265	32.13	1.035	26.29	1.460	37.08
J	2.261	57.43	1.975	50.17	1.615	41.02	1.390	35.31	1.810	45.97
K	2.661	67.59	2.375	60.33	2.015	51.18	1.795	45.59	2.210	56.13

Dimensions in Inches (millimeters) are subject to change without notice.

790-027S
**Crimp Terminated Panel Mount Plugs,
 Socket Contacts**
Dimensions



790-027S Shell Size G Dimensions

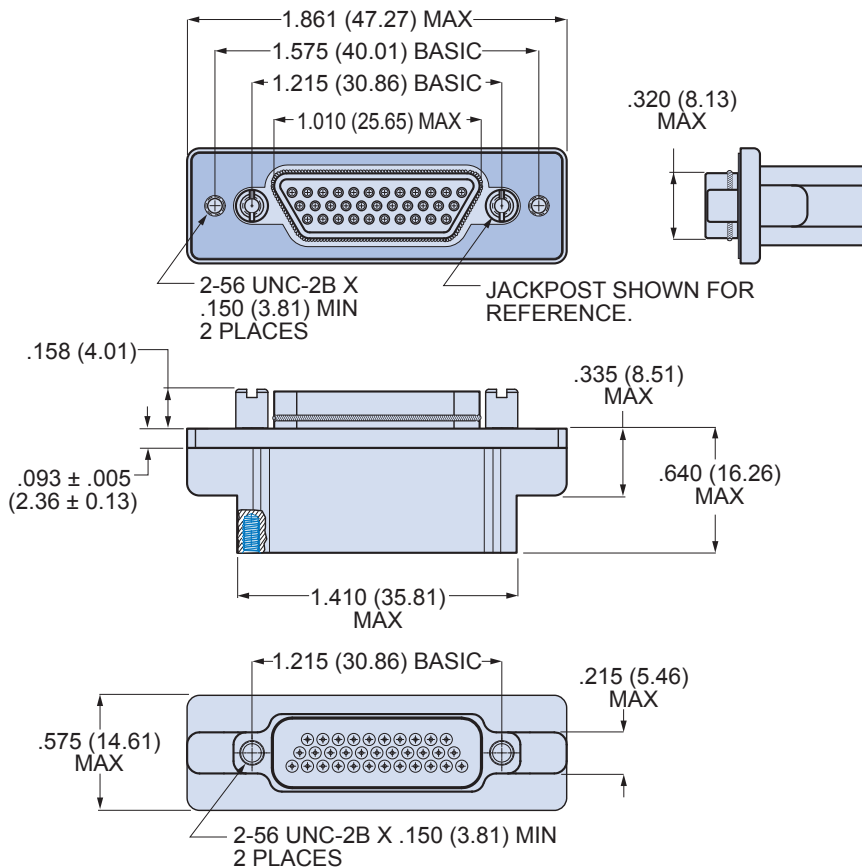

BLIND MATE

SHELL SIZES A, B, C, D, E, F, G, J, K
 +/- .030 (0.76) ALLOWABLE
 MISALIGNMENT FROM CENTERLINE



Dimensions in Inches (millimeters) are subject to change without notice.

790-027S Shell Size H and L Dimensions

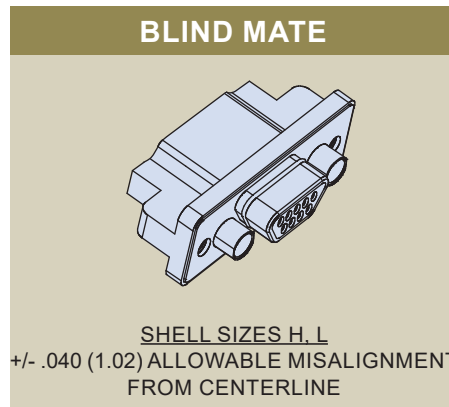
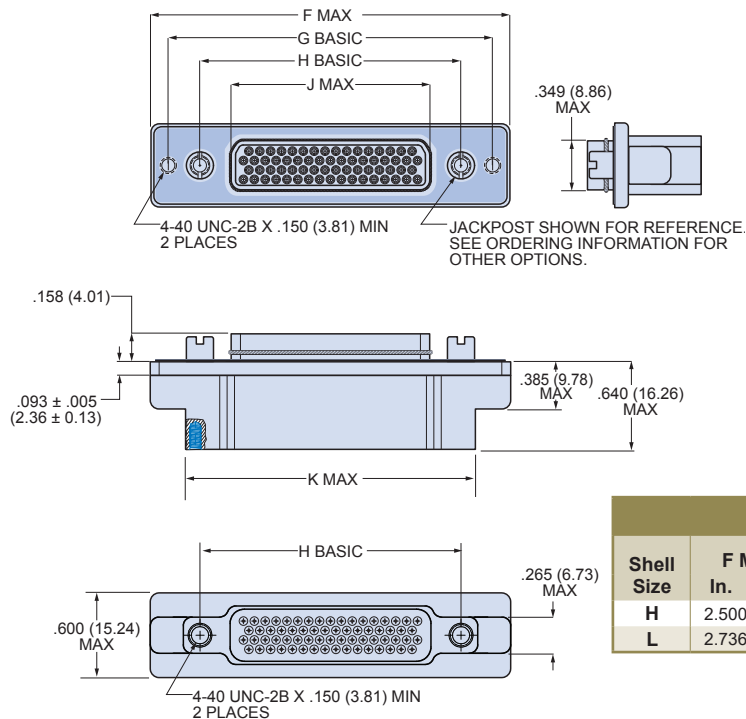

790-027S SIZE H & L DIMENSIONS										
Shell Size	F Max.		G Basic		H Basic		J Max.		K Max.	
	In.	mm.	In.	mm.	In.	mm.	In.	mm.	In.	mm.
H	2.500	63.50	2.236	56.79	1.800	45.72	1.385	35.18	2.045	51.94
L	2.736	69.49	2.472	62.79	2.036	51.71	1.623	41.22	2.281	57.94

790-027S Shell Size M Dimensions

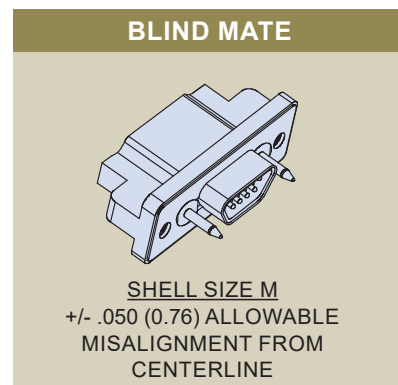
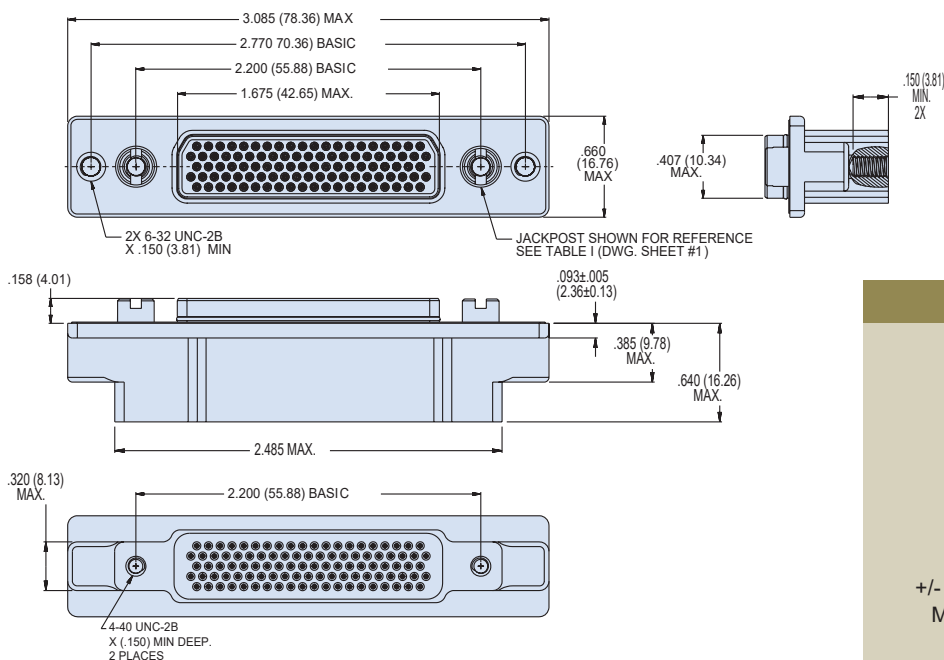

Dimensions in Inches (millimeters) are subject to change without notice.

790-050P
Crimp Terminated Rear Panel
Float Mount Receptacles, Pin Contacts
How To Order



790-050P Rear Panel Float Mount Receptacles
PIN CONTACTS WITH CRIMP TERMINATION

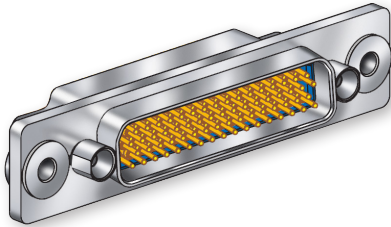

790-050P connectors are equipped with rear-panel float mounting assemblies to provide additional mounting leeway in rack and panel applications. These connectors feature machined aluminum shells and wire grommets for environmental protection. Contacts are rear-release snap-in crimp type. Connectors are supplied with crimp contacts packaged separately. Size #23 signal pins accept up to #22 AWG wire. Size #16 contacts accept #16-18 AWG wire. Size #12 contacts accept #12-14 AWG wire. Size 12 and 16 cavities also accept coaxial contacts purchased separately. Attach optional shielding adapters (799-016) for EMI protection.

HOW TO ORDER

Sample Part Number

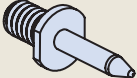
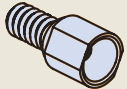
790-050P	H-66	M	N
Part Number	Shell Size - Insert Arrangements	Shell Finish	Hardware Option
790-050P Rear Panel Float Mounted Receptacle with Pin Contacts	See Table I for Available Insert Arrangements To order a connector without size #16 or #12 power pins, substitute "W" instead of "P" in the insert arrangement. Example: 36P2 is supplied with 2 power pins. 36W2 is supplied less the power pins. See Section B for coaxial contacts purchased separately.	M Electroless Nickel <i>general purpose applications</i> MT Nickel-PTFE 1000 Hour Grey™ <i>maximum corrosion protection and durability</i> <i>(non-reflective grey)</i> ZNU Zinc-Nickel with Black Chromate <i>tactical applications</i> <i>(non-reflective black)</i> Additional shell finishes are listed on page C-9.	 N No Hardware  G Guide Pin  S Female Guide Socket

SPECIFICATIONS

Current Rating	#23 5 AMPS, #16 13 A., #12 23 A.
Dielectric Withstanding Voltage	#23 500 VAC RMS, #12 and #16 1800 VAC RMS
Insulation Resistance	5000 megohms minimum
Operating Temperature	-65° C. to +150° C.
Shock	300 g.
Vibration	37 g.

MATERIALS AND FINISHES

Shell	Aluminum alloy
Contacts	Copper alloy, 50 microinches gold plated, stainless steel hood
Insulators	Liquid crystal polymer (LCP)
Retention Clips	Beryllium copper alloy
Grommet	Flourosilicone rubber
Hardware	300 series stainless steel

Dimensions in Inches (millimeters) are subject to change without notice.





790-050P Crimp Terminated Rear Panel Float Mount Receptacles, Pin Contacts How To Order

Table 1 Contact Arrangements

Layout	Contact Quantity		Face View
	#23	#16#12	
A-5	5		
B-2P2	2		
B-9	9		
C-13	13		
D-15	15		
D-3P3	3		
D-7P2	5	2	
E-11P2	9	2	
E-19	19		
E-7P3	4	3	
F-15P2	13	2	
F-23	23		
F-5P5	5		
G-33	33		
H-10P4	6	4	
H-29P7	22	7	
H-36P2	34	2	
H-54P2	52	2	
H-5P5		5	
H-66	66		
J-17P4	13	4	
J-25P2	23	2	
J-33	33		
J-7P7	7		
K-27P4	23	4	
K-35P2	33	2	
K-43	43		
K-9P9	9		
L-6P6		6	
L-78	78		
M-102	102		

CROSS-SECTIONAL VIEW OF 790-050P

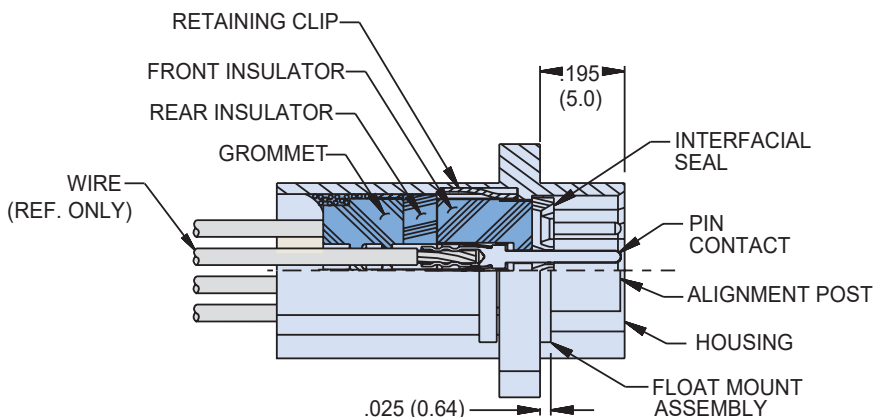
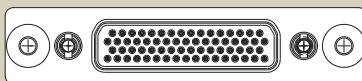

TABLE 2 HARDWARE OPTION



N

No Mating Hardware

Connector is supplied with threaded holes. Shell size M has #8-32 threads, shell sizes H and L have #6-32 threads, other sizes have #4-40 threads. Thread depth is .150" (3.8).

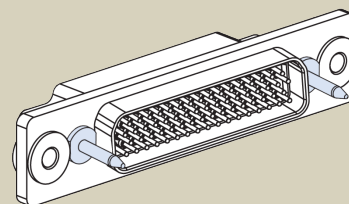

G

Guide Pins

Connector is supplied with stainless steel non-removable guide pins. Mates with type "S" guide sockets on corresponding receptacle connector.

S

Guide Sockets

Connector is supplied with stainless steel non-removable bushings. Mates with type "G" guide pins on corresponding receptacle connector.

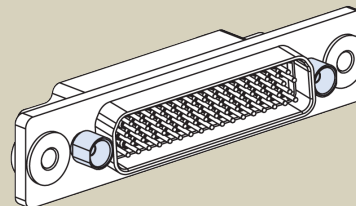

Dimensions in Inches (millimeters) are subject to change without notice.

790-050P
Crimp Terminated Rear Panel
Float Mount Receptacles, Pin Contacts
Dimensions



790-050P Shell Sizes A, B, C, D, E, F, J and K Dimensions

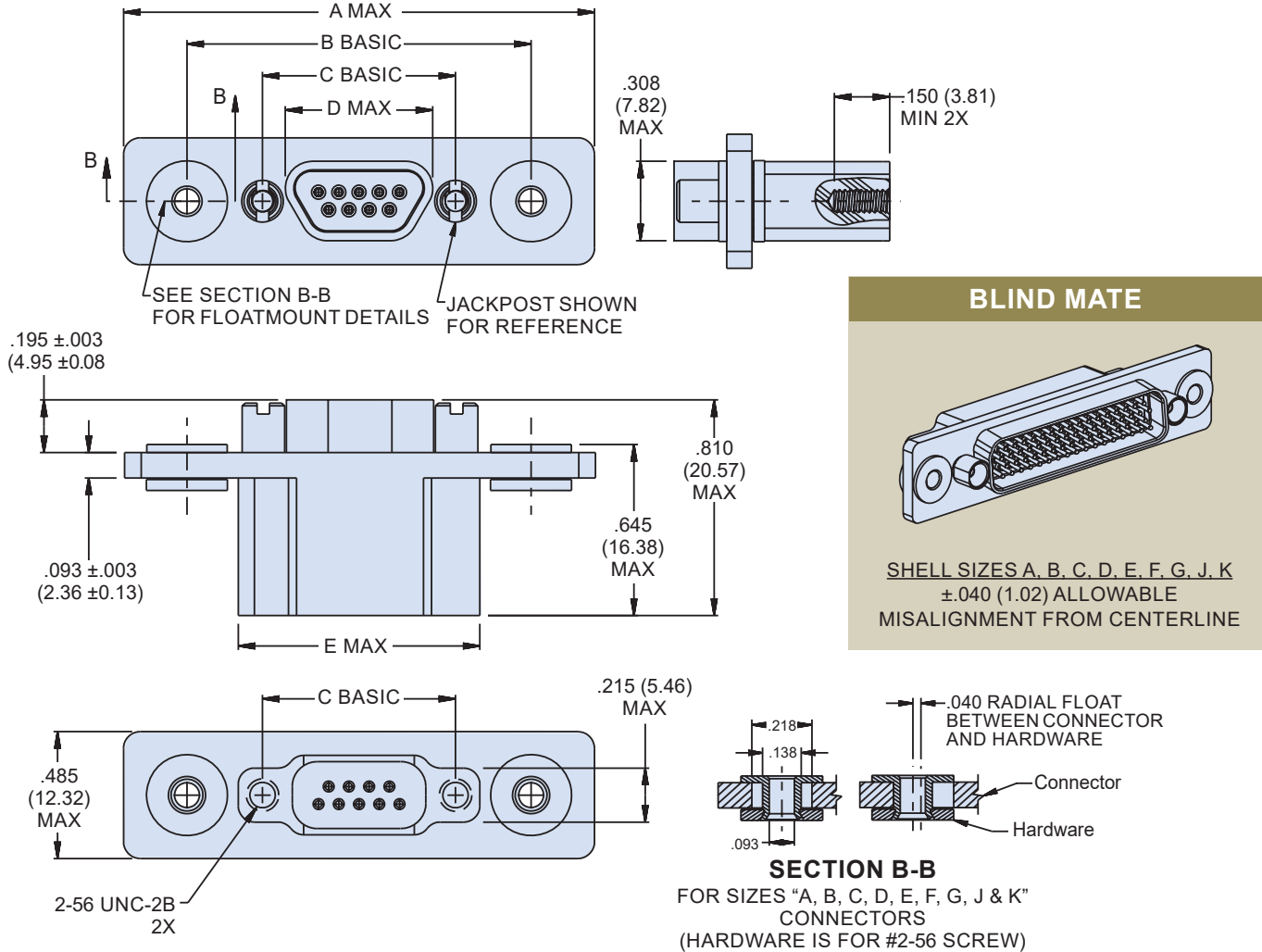

790-050P SIZES A, B, C, D, E, F, G, J & K DIMENSIONS										
Shell Size	A Max.		B Basic		C Basic		D Max.		E Max.	
	In.	mm.	In.	mm.	In.	mm.	In.	mm.	In.	mm.
A	1.600	40.64	1.125	28.58	.565	14.35	.401	10.19	.760	19.30
B	1.700	43.18	1.275	32.38	.715	18.16	.551	14.00	.910	21.11
C	1.900	48.26	1.425	36.20	.865	21.97	.701	17.81	1.060	26.92
D	2.000	50.80	1.525	38.74	.965	25.51	.801	20.35	1.160	29.46
E	2.150	54.61	1.675	42.55	1.115	28.32	.951	24.16	1.310	33.27
F	2.300	58.42	1.825	46.36	1.265	32.13	1.101	27.96	1.460	37.08
J	2.650	67.31	2.175	55.25	1.615	41.02	1.456	36.98	1.810	45.97
K	3.050	77.47	2.575	65.41	2.015	51.18	1.860	47.24	2.210	56.13

Dimensions in Inches (millimeters) are subject to change without notice.



790-050P
Crimp Terminated Rear Panel
Float Mount Receptacles, Pin Contacts
Dimensions

790-050P Shell Size G Dimensions

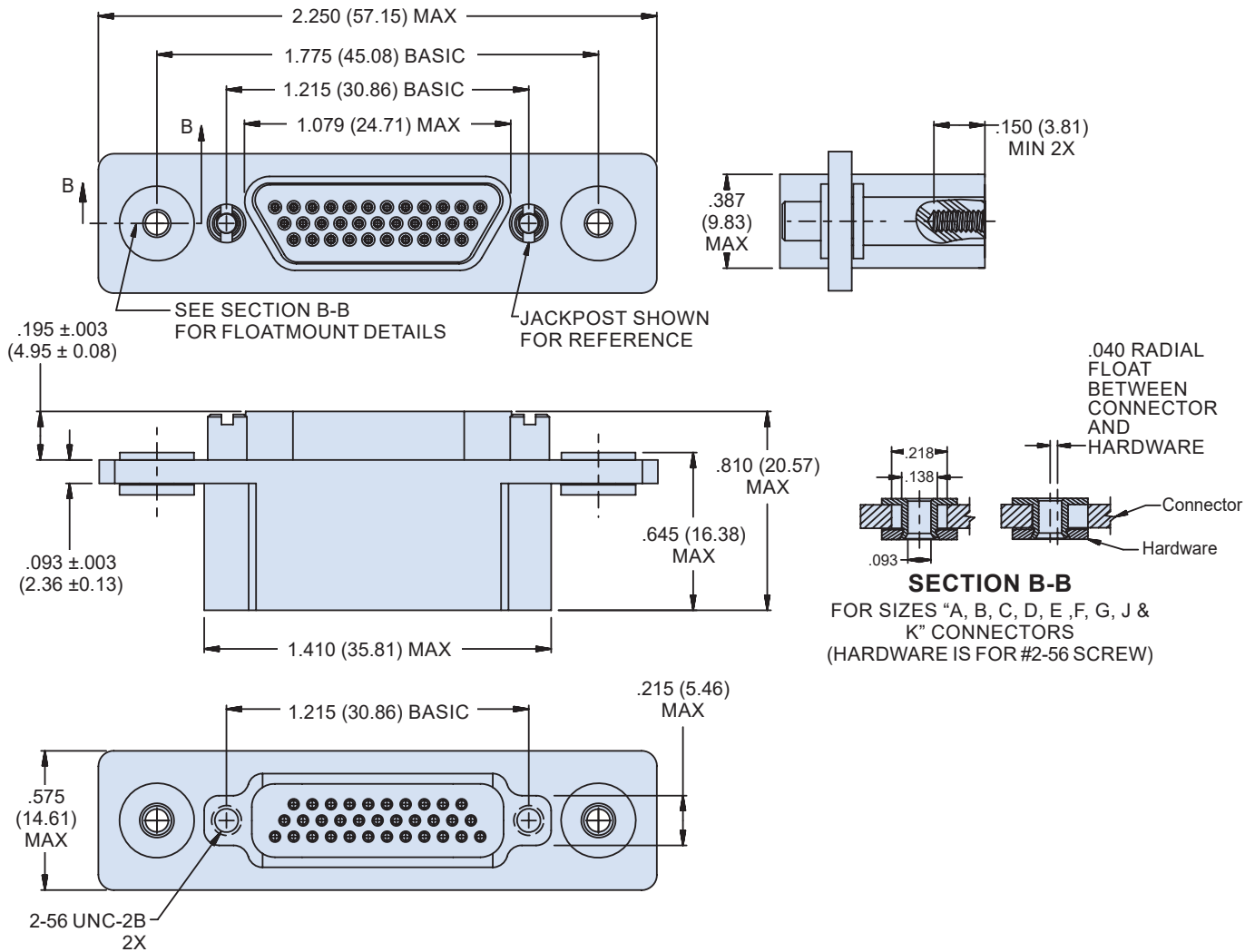

E

Dimensions in Inches (millimeters) are subject to change without notice.

790-050P
Crimp Terminated Rear Panel
Float Mount Receptacles, Pin Contacts
Dimensions



790-050P Shell Sizes H and L Dimensions

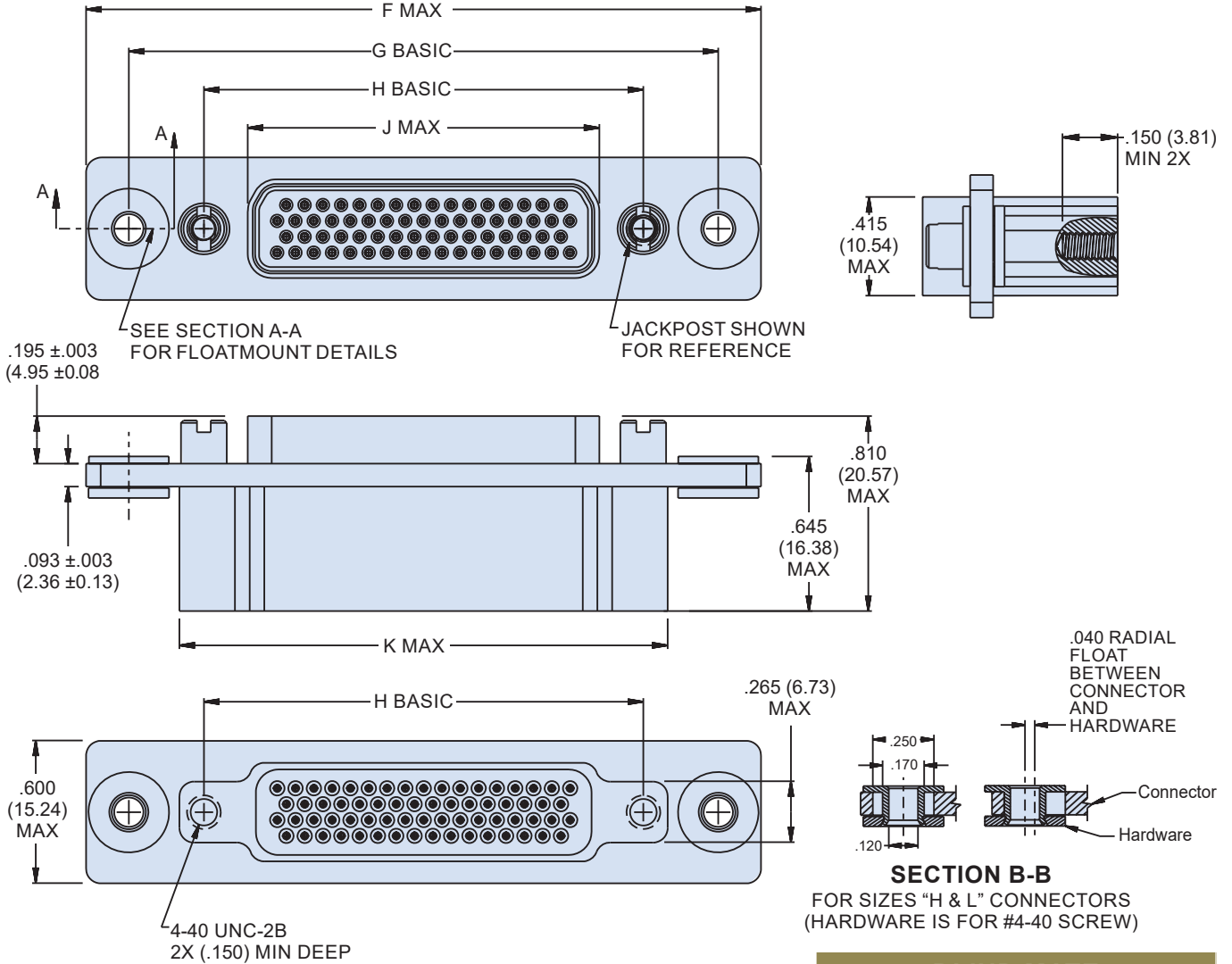

790-050P SIZES H & L DIMENSIONS										
Shell Size	A Max.		B Basic		C Basic		D Max.		E Max.	
	In.	mm.	In.	mm.	In.	mm.	In.	mm.	In.	mm.
H	2.780	70.61	2.415	61.34	1.800	45.72	1.450	36.83	2.045	51.94
L	3.016	76.61	2.651	67.34	2.036	51.71	1.686	42.82	2.281	57.94

BLIND MATE

SHELL SIZES H, L
 ±.040 (1.02) ALLOWABLE
 MISALIGNMENT FROM CENTERLINE

Dimensions in Inches (millimeters) are subject to change without notice.



790-050P
Crimp Terminated Rear Panel
Float Mount Receptacles, Pin Contacts
Dimensions

790-050P Shell Size M Dimensions

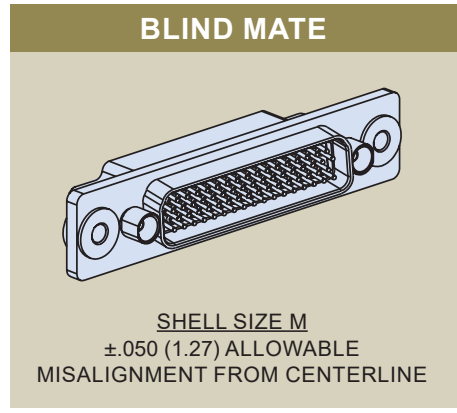
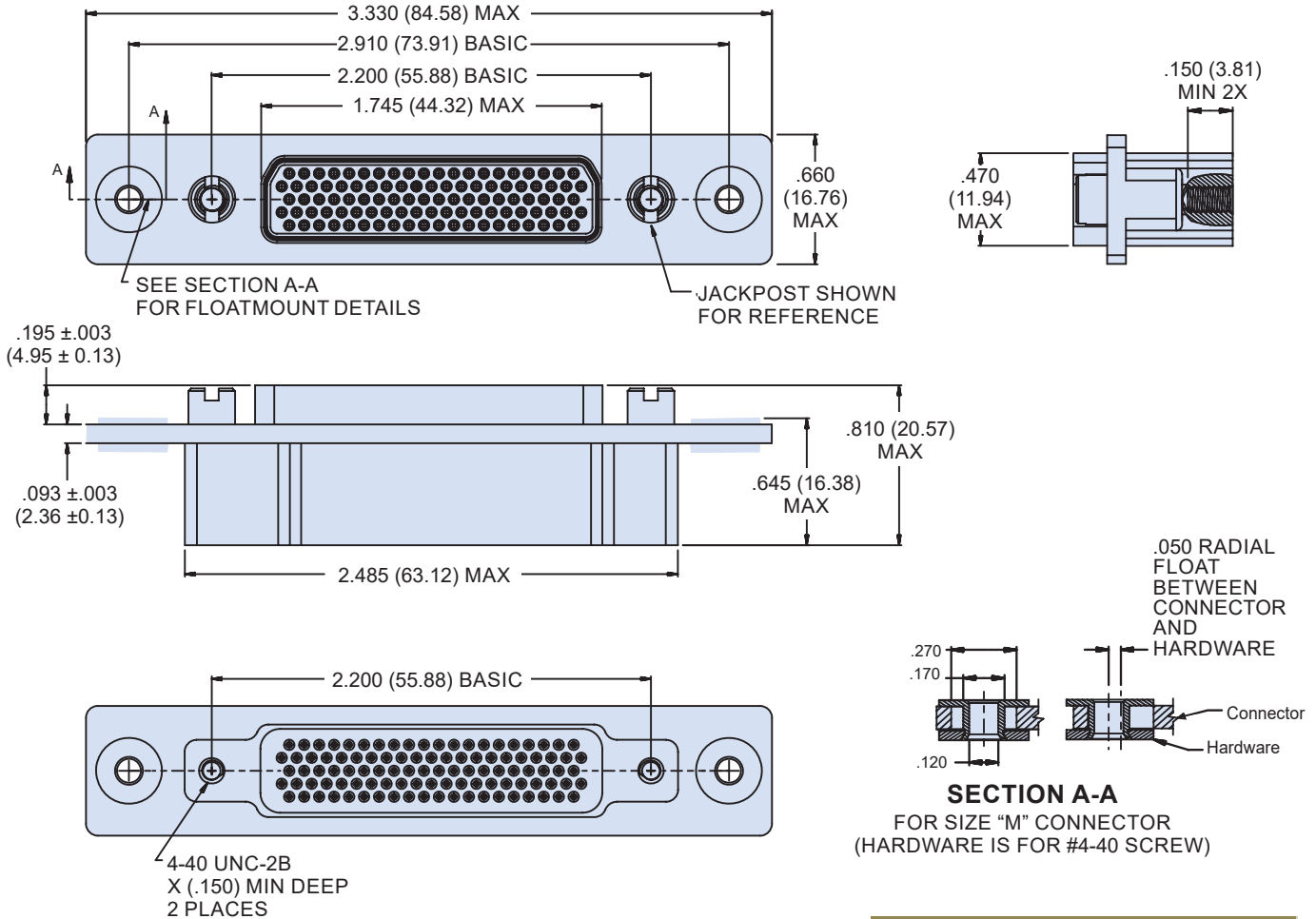

Dimensions in Inches (millimeters) are subject to change without notice.

790-049S
Crimp Terminated Rear Panel
Float Mount Plugs, Socket Contacts
How To Order



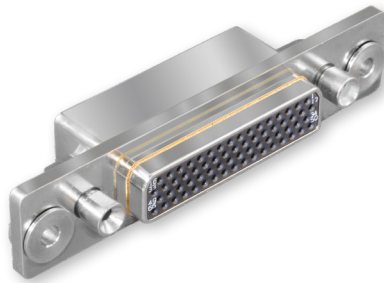

790-049S Rear Panel Float Mount Plugs
SOCKET CONTACTS WITH CRIMP TERMINATION



790-049S connectors are equipped with rear-panel float mounting assemblies to provide additional mounting leeway in rack and panel applications. These connectors feature machined aluminum shells and wire grommets for environmental protection. Contacts are rear-release snap-in crimp type. Connectors are supplied with crimp contacts packaged separately. Size #23 signal pins accept up to #22 AWG wire. Size #16 contacts accept #16-18 AWG wire. Size #12 contacts accept #12-14 AWG wire. Size 12 and 16 cavities also accept coaxial contacts purchased separately. Attach optional shielding adapters (799-016) for EMI protection.

HOW TO ORDER

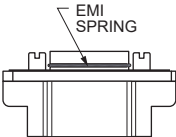
Sample Part Number

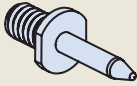
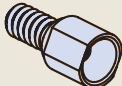
790-049S	H-66	M	E	N
Part Number	Shell Size - Insert Arrangements	Shell Finish	EMI Spring	Hardware Option
790-049S Rear Panel Float Mounted Receptacle with Socket Contacts	See Table I for Available Insert Arrangements To order a connector without size #16 or #12 power pins, substitute "W" instead of "P" in the insert arrangement. Example: 36P2 is supplied with 2 power pins. 36W2 is supplied less the 3 power pins. See Section B for coaxial contacts purchased separately.	M Electroless Nickel <i>general purpose applications</i> MT Nickel-PTFE <i>1000 Hour Grey™ maximum corrosion protection and durability (non-reflective grey)</i> ZNU Zinc-Nickel with Black Chromate <i>tactical applications (non-reflective black)</i> Additional shell finishes are listed on page C-9.	E EMI Spring N No Spring  Note: EMI Spring is not compatible with chromate finishes including cadmium and zinc-nickel	 N No Hardware  G Guide Pin  S Female Guide Socket

SPECIFICATIONS

Current Rating	#23 5 AMPS, #16 13 A., #12 23 A.
Dielectric Withstanding Voltage	#23 500 VAC RMS, #12 and #16 1800 VAC RMS
Insulation Resistance	5000 megohms minimum
Operating Temperature	-65° C. to +150° C.
Shock	300 g.
Vibration	37 g.

MATERIALS AND FINISHES

Shell	Aluminum alloy
Contacts	Copper alloy, 50 microinches gold plated, stainless steel hood
Insulators	Liquid crystal polymer (LCP)
Retention Clips	Beryllium copper alloy
Grommet	Flourosilicone rubber
Hardware	300 series stainless steel

Dimensions in Inches (millimeters) are subject to change without notice.



790-049S Crimp Terminated Rear Panel Float Mount Plugs, Socket Contacts How To Order

Table 1 Contact Arrangements

Layout	Contact Quantity		Face View
	#23	#16#12	
A-5	5		
B-2P2	2		
B-9	9		
C-13	13		
D-15	15		
D-3P3	3		
D-7P2	5	2	
E-11P2	9	2	
E-19	19		
E-7P3	4	3	
F-15P2	13	2	
F-23	23		
F-5P5	5		
G-33	33		
H-10P4	6	4	
H-29P7	22	7	
H-36P2	34	2	
H-54P2	52	2	
H-5P5		5	
H-66	66		
J-17P4	13	4	
J-25P2	23	2	
J-33	33		
J-7P7	7		
K-27P4	23	4	
K-35P2	33	2	
K-43	43		
K-9P9	9		
L-6P6		6	
L-78	78		
M-102	102		

CROSS-SECTIONAL VIEW OF 790-049S

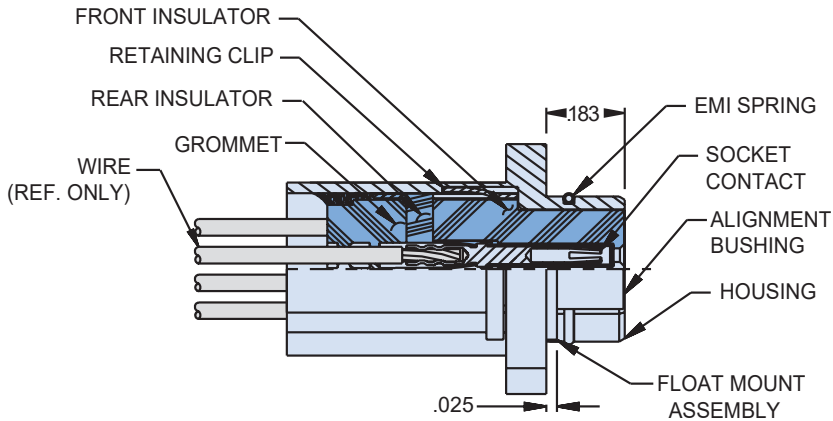

TABLE 2 HARDWARE OPTION

 N No Mating Hardware Connector is supplied with threaded holes. Shell size M has #8-32 threads, shell sizes H and L have #6-32 threads, other sizes have #4-40 threads. Thread depth is .150" (3.8).	 G Guide Pins Connector is supplied with stainless steel non-removable guide pins. Mates with type "S" guide sockets on corresponding receptacle connector.
 S Guide Sockets Connector is supplied with stainless steel non-removable bushings. Mates with type "G" guide pins on corresponding receptacle connector.	

Dimensions in Inches (millimeters) are subject to change without notice.

790-049S
Crimp Terminated Rear Panel
Float Mount Plugs, Socket Contacts
Dimensions



790-049S Shell Sizes A, B, C, D, E, F, J and K Dimensions

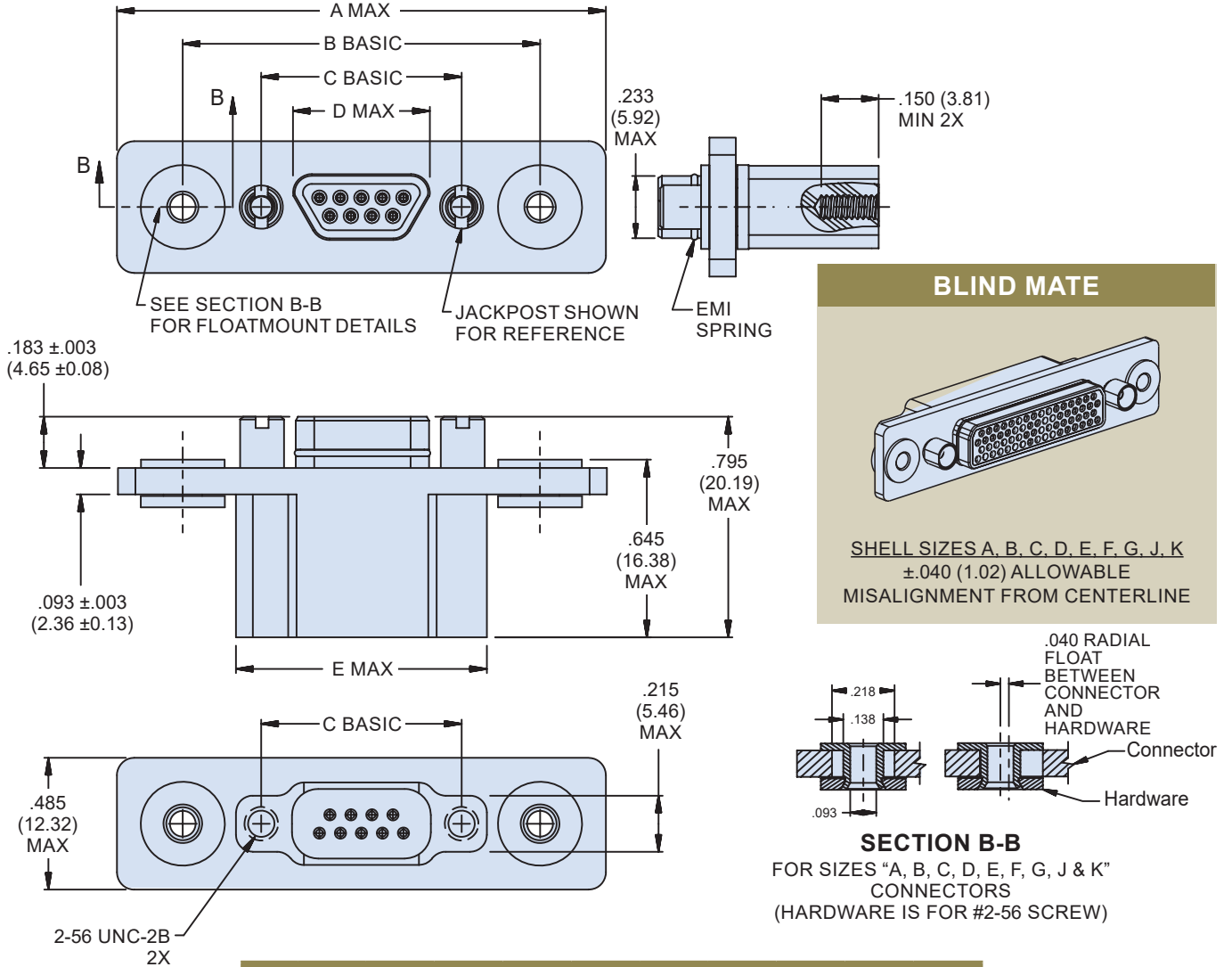

790-049S SIZES A, B, C, D, E, F, G, J & K DIMENSIONS										
Shell Size	A Max.		B Basic		C Basic		D Max.		E Max.	
	In.	mm.	In.	mm.	In.	mm.	In.	mm.	In.	mm.
A	1.600	40.64	1.125	28.58	.565	14.35	.335	8.51	.760	19.30
B	1.700	43.18	1.275	32.38	.715	18.16	.485	12.32	.910	21.11
C	1.900	48.26	1.425	36.20	.865	21.97	.635	16.13	1.060	26.92
D	2.000	50.80	1.525	38.74	.965	25.51	.735	18.67	1.160	29.46
E	2.150	54.61	1.675	42.55	1.115	28.32	.885	22.48	1.310	33.27
F	2.300	58.42	1.825	46.36	1.265	32.13	1.035	26.29	1.460	37.08
J	2.650	67.31	2.175	55.25	1.615	41.02	1.390	35.31	1.810	45.97
K	3.050	77.47	2.575	65.41	2.015	51.18	1.795	45.59	2.210	56.13

Dimensions in Inches (millimeters) are subject to change without notice.

790-049S Shell Size G Dimensions

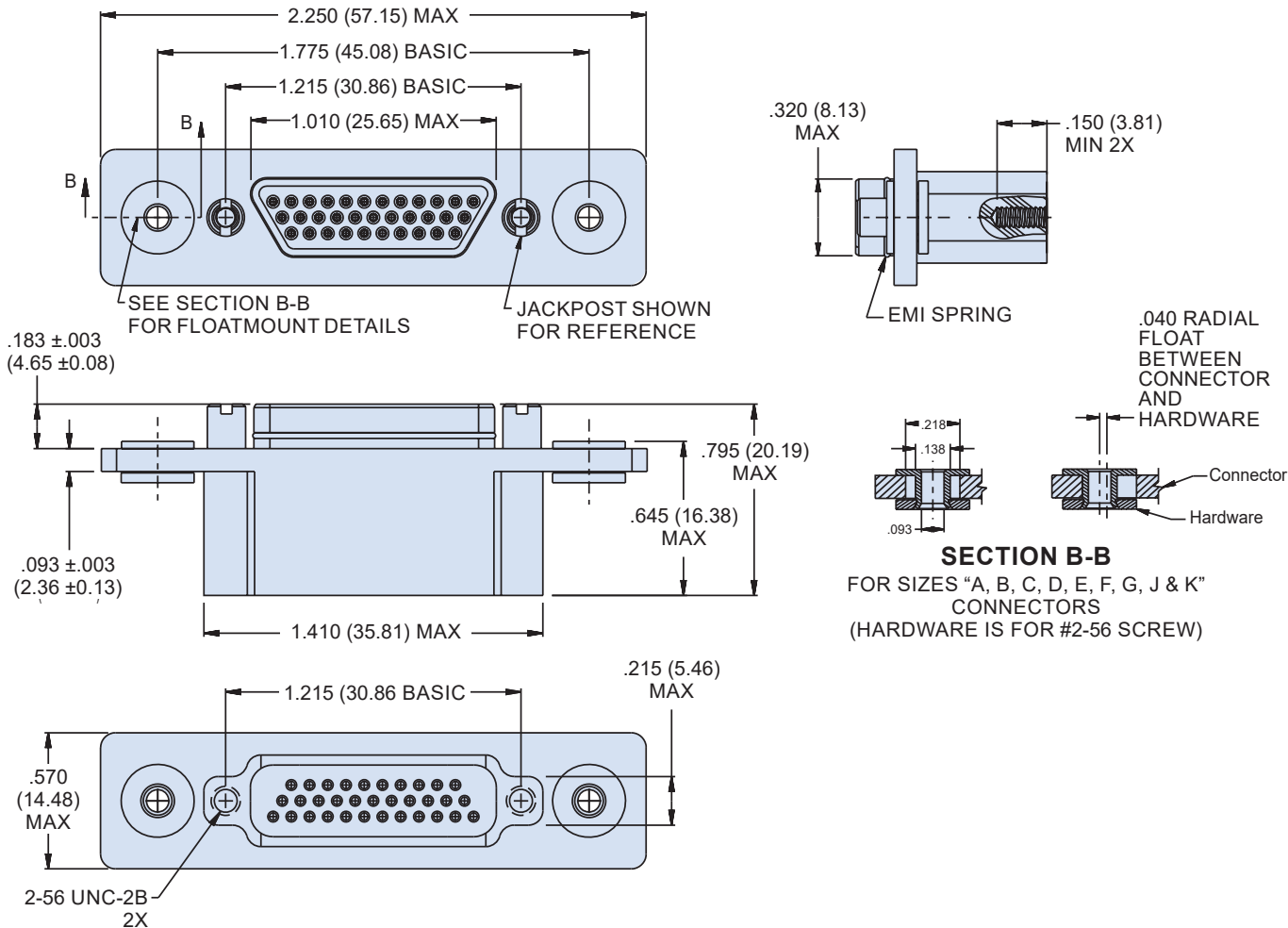

Dimensions in Inches (millimeters) are subject to change without notice.

790-049S
Crimp Terminated Rear Panel
Float Mount Plugs, Socket Contacts
Dimensions



790-049S Shell Sizes H and L Dimensions

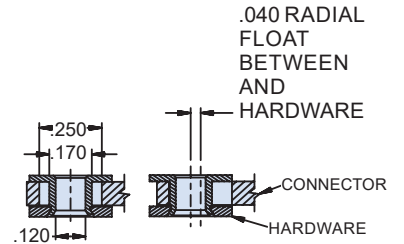
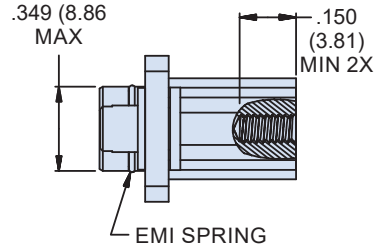
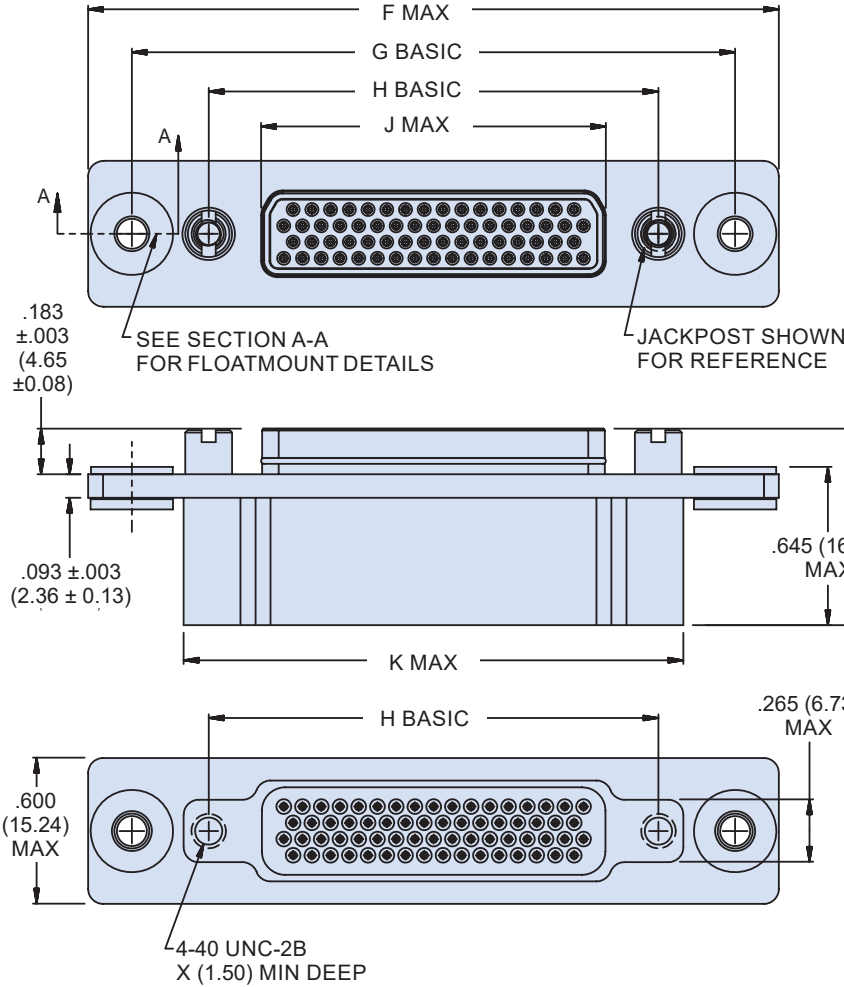

SECTION A-A
 FOR SIZES "H & L" CONNECTORS
 (HARDWARE IS FOR #4-40 SCREW)

BLIND MATE

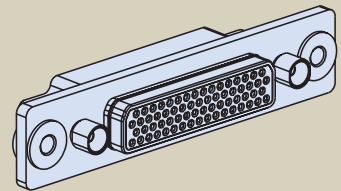

SHELL SIZES H, L
 ±.040 (1.02) ALLOWABLE
 MISALIGNMENT FROM CENTERLINE

790-050P SIZES H & L DIMENSIONS

Shell Size	F Max.		G Basic		H Basic		J Max.		K Max.	
	In.	mm.	In.	mm.	In.	mm.	In.	mm.	In.	mm.
H	2.780	70.61	2.415	61.34	1.800	45.72	1.385	35.18	2.045	51.94
L	3.016	76.61	2.651	67.34	2.036	51.71	1.623	41.22	2.281	57.94

Dimensions in Inches (millimeters) are subject to change without notice.



790-049S
Crimp Terminated Rear Panel
Float Mount Plugs, Socket Contacts
Dimensions

790-049S Shell Size M Dimensions

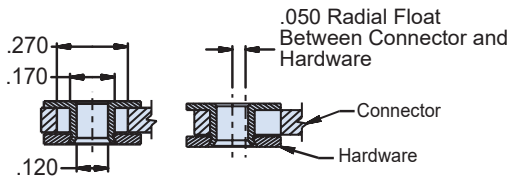
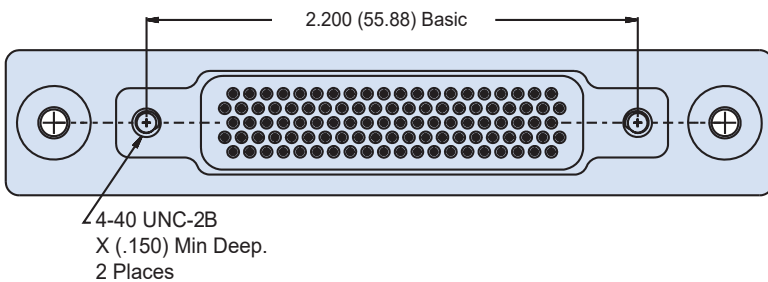
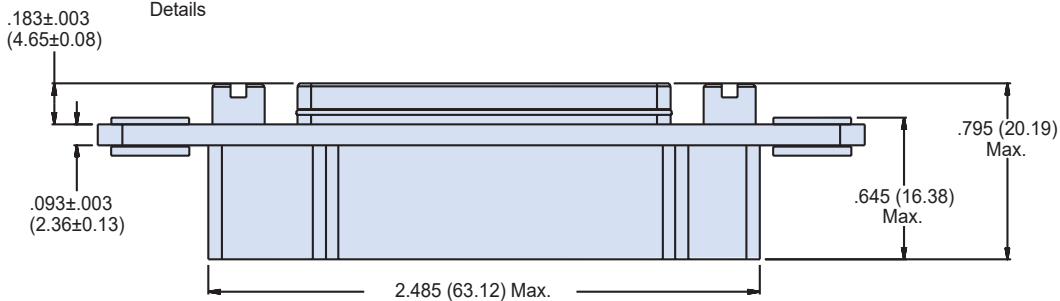
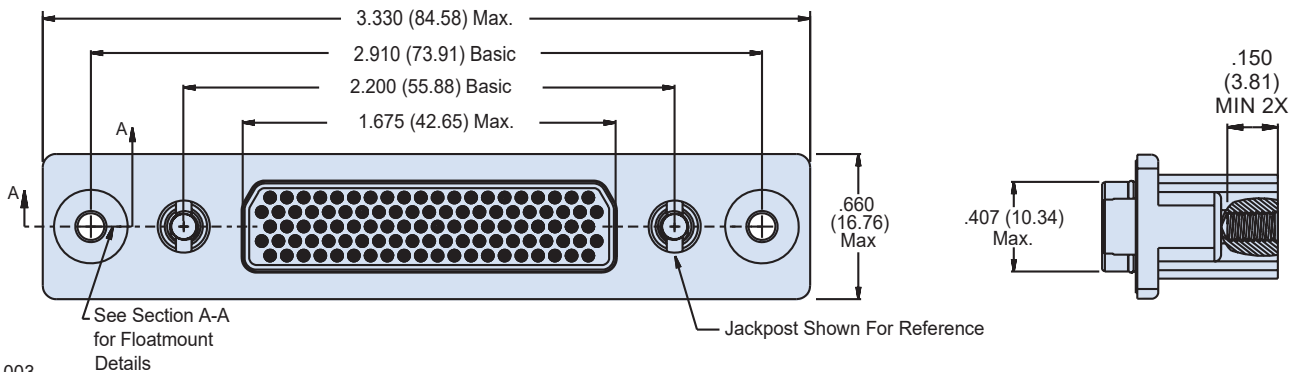

Section A-A
For Size "M" Connector
(Hardware Is For #4-40 Screw)

BLIND MATE

SHELL SIZE M
±.050 (1.27) ALLOWABLE
MISALIGNMENT FROM CENTERLINE

Dimensions in Inches (millimeters) are subject to change without notice.

790-071P
Solder Cup Terminated Panel Mount Receptacles,
Pin Contacts
How To Order



790-071P Panel Mount Receptacles PIN CONTACTS WITH SOLDER CUP TERMINATION

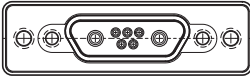
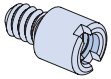
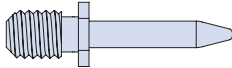
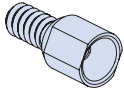

790-071P connectors are designed for rear-panel mounting and are supplied with conductive panel gaskets. These connectors feature machined aluminum shells and fluorosilicone face seals. Contacts are rear-release snap-in solder cup type. Connectors are supplied with solder cup contacts packaged separately. Size #23 signal pins accept up to #22 AWG wire. Size #16 contacts accept #16-18 AWG wire. Size #12 contacts accept #12-14 AWG wire. Size 12 and 16 cavities also accept coaxial contacts purchased separately. Attach optional shielding adapters (799-016) for EMI protection.

HOW TO ORDER			
Sample Part Number			
790-071P	H-66	M	P
Part Number	Shell Size - Insert Arrangement	Shell Finish	Hardware Option
<p>790-071P Rear Panel Mounted Receptacle with Solder Cup Pin Contacts</p>	<p>See Table 1 for Available Insert Arrangements</p> <p>To order a connector without size #16 or #12 power pins, substitute "W" instead of "P" in the insert arrangement.</p> <p>Example:</p> <p>36P2 is supplied with 2 power pins.</p> <p>36W2 is supplied less the power pins.</p> <p>See Section B for coaxial contacts purchased separately.</p>	<p>M Electroless Nickel <i>general purpose applications</i></p> <p>MT Nickel-PTFE 1000 Hour Grey™ <i>maximum corrosion protection and durability (non-reflective grey)</i></p> <p>ZNU Zinc-Nickel with Black Chromate <i>tactical applications (non-reflective black)</i></p> <p>Additional shell finishes are listed on page C-9.</p>	<div style="display: flex; justify-content: space-around;"> <div style="text-align: center;">  <p>N No Hardware</p> </div> <div style="text-align: center;">  <p>P Female Jackpost</p> </div> </div> <div style="display: flex; justify-content: space-around; margin-top: 20px;"> <div style="text-align: center;">  <p>G Guide Pin</p> </div> <div style="text-align: center;">  <p>S Female Guide Socket</p> </div> </div>

SPECIFICATIONS	
Current Rating	#23 5 AMPS, #16 13 A., #12 23 A.
Dielectric Withstanding Voltage	#23 500 VAC RMS, #12 and #16 1800 VAC RMS
Insulation Resistance	5000 megohms minimum
Operating Temperature	-65° C. to +150° C.
Shock	300 g.
Vibration	37 g.

MATERIALS AND FINISHES	
Shell	Aluminum alloy
Contacts	Copper alloy, 50 microinches gold plated
Insulators	Liquid crystal polymer (LCP)
Retention Clips	Beryllium copper alloy
Interfacial Seal, Grommet	Fluorosilicone rubber
Hardware	300 series stainless steel
Panel Gasket	Fluorosilicone, conductive

Dimensions in Inches (millimeters) are subject to change without notice.



790-071P Solder Cup Terminated Panel Mount Receptacles, Pin Contacts How To Order

Table 1 Contact Arrangements

Layout	Contact Quantity			Face View
	#23	#16	#12	
A-5	5			
B-2P2	2			
B-9	9			
C-13	13			
D-15	15			
D-3P3	3			
D-7P2	5	2		
E-11P2	9	2		
E-19	19			
E-7P3	4	3		
F-15P2	13	2		
F-23	23			
F-5P5	5			
G-33	33			
H-10P4	6	4		
H-29P7	22	7		
H-36P2	34	2		
H-54P2	52	2		
H-5P5		5		
H-66	66			
J-17P4	13	4		
J-25P2	23	2		
J-33	33			
J-7P7	7			
K-27P4	23	4		
K-35P2	33	2		
K-43	43			
K-9P9	9			
L-6P6		6		
L-78	78			
M-102	102			

CROSS-SECTIONAL VIEW OF 790-071P

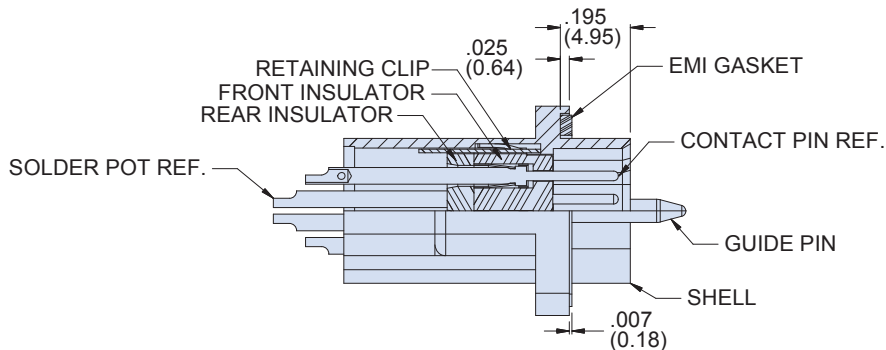
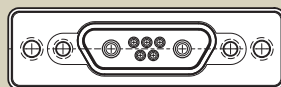

TABLE 2 HARDWARE OPTION



N

No Mating Hardware

Connector is supplied with threaded holes. Shell size M has #8-32 threads, shell sizes H and L have #6-32 threads, other sizes have #4-40 threads. Thread depth is .150" (3.8).

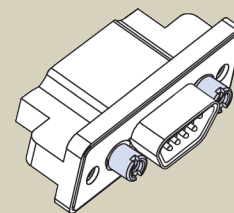

P

Jackposts

Connector is supplied with non-removable stainless steel jackposts. Shell sizes H and L have #4-40 UNC thread, other sizes have #2-56 thread. Stainless steel.

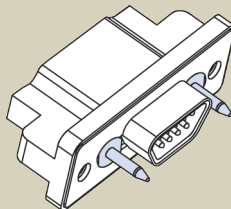

G

Guide Pins

Connector is supplied with stainless steel non-removable guide pins. Mates with type "S" guide sockets on corresponding plug connector.

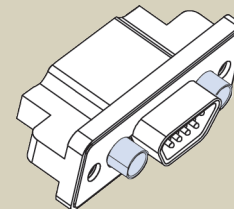

S

Guide Sockets

Connector is supplied with stainless steel non-removable bushings. Mates with type "G" guide pins on corresponding plug connector.

Dimensions in Inches (millimeters) are subject to change without notice.

790-071P
Solder Cup Terminated Panel Mount Receptacles,
Pin Contacts
Dimensions



790-071P Shell Size A, B, C, D, E, F, J, K Dimensions

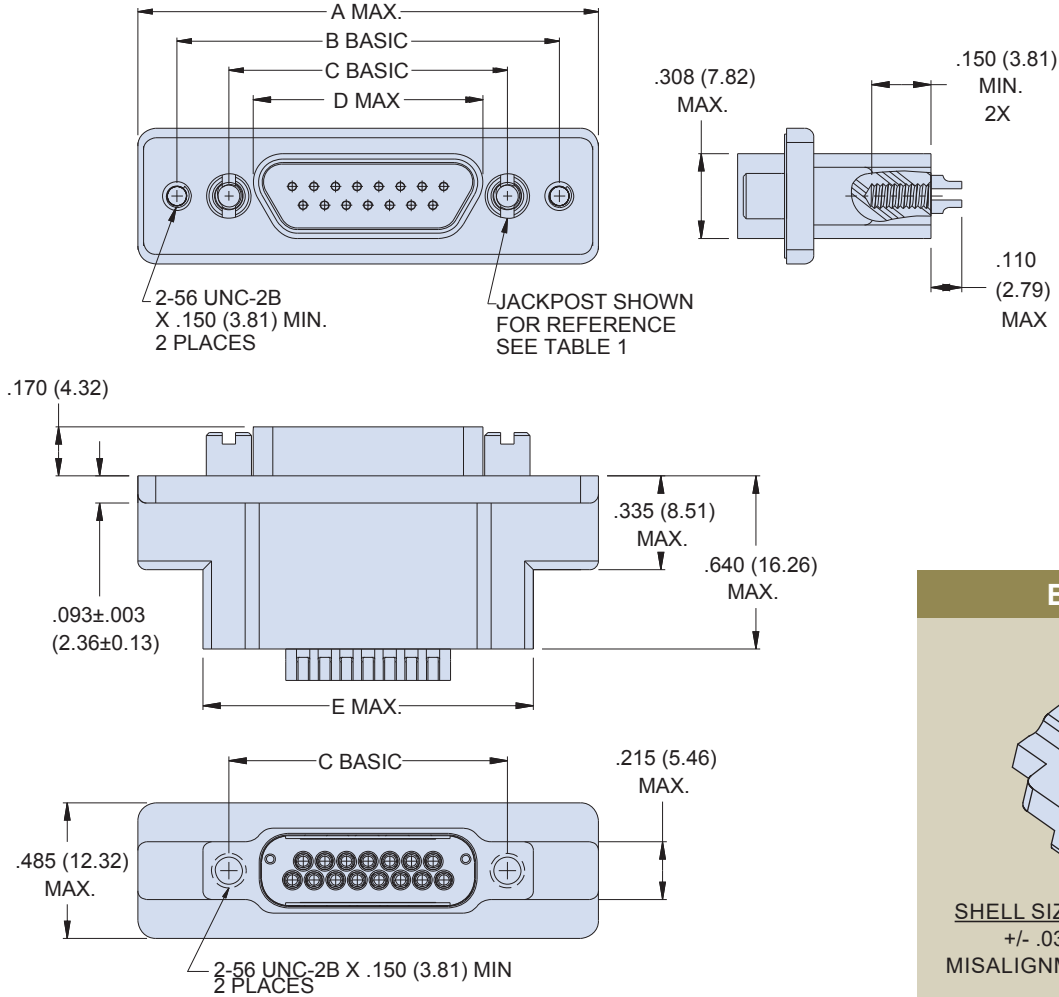

BLIND MATE

SHELL SIZES A, B, C, D, E, F, G, J, K
 +/- .030 (0.76) ALLOWABLE
 MISALIGNMENT FROM CENTERLINE

E

790-071P Dimensions for Size A-F, J and K										
Shell Size	A Max.		B Basic		C Basic		D Max.		E Max.	
	In.	mm.	In.	mm.	In.	mm.	In.	mm.	In.	mm.
A	1.211	30.76	.925	23.50	.565	14.35	.401	10.19	.760	19.30
B	1.361	34.57	1.075	27.31	.715	18.16	.551	14.00	.910	21.11
C	1.511	38.38	1.225	31.12	.865	21.97	.701	17.81	1.060	26.92
D	1.611	40.92	1.325	33.66	.965	24.51	.801	20.35	1.160	29.46
E	1.761	44.73	1.475	37.47	1.115	28.32	.951	24.16	1.310	33.27
F	1.911	48.54	1.625	41.28	1.265	32.13	1.101	27.96	1.460	37.08
J	2.261	57.43	1.975	50.17	1.615	41.02	1.460	37.08	1.810	45.97
K	2.661	67.59	2.375	60.33	2.015	51.18	1.860	47.24	2.210	56.13

Dimensions in Inches (millimeters) are subject to change without notice.



790-071P Solder Cup Terminated Panel Mount Receptacles, Pin Contacts Dimensions

790-071P Shell Size G Dimensions

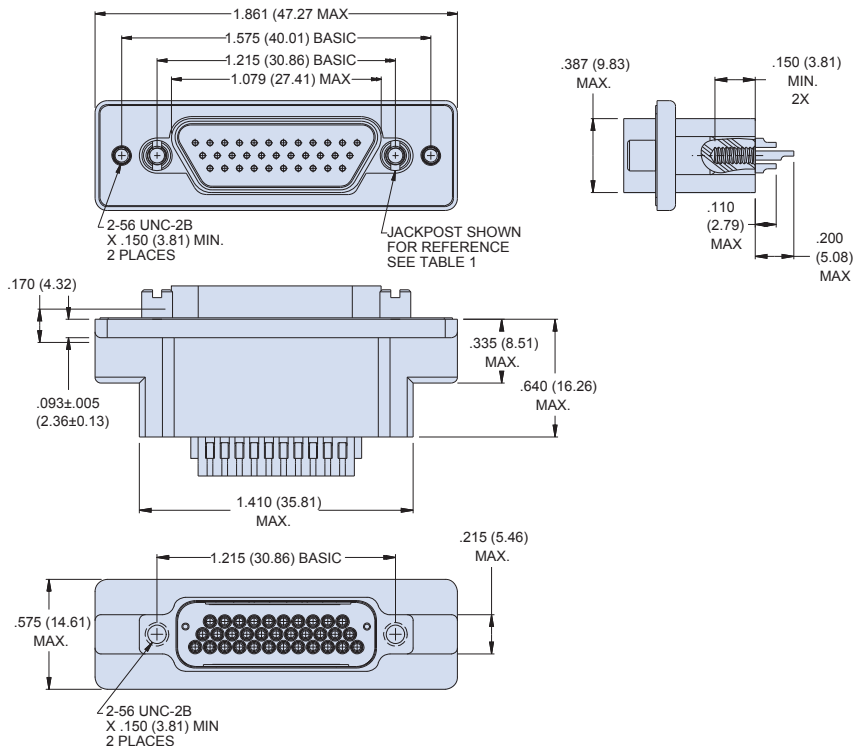

BLIND MATE

SHELL SIZES A, B, C, D, E, F, G, J, K
+/- .030 (0.76) ALLOWABLE
MISALIGNMENT FROM
CENTERLINE

790-071P Shell Size H and L Dimensions

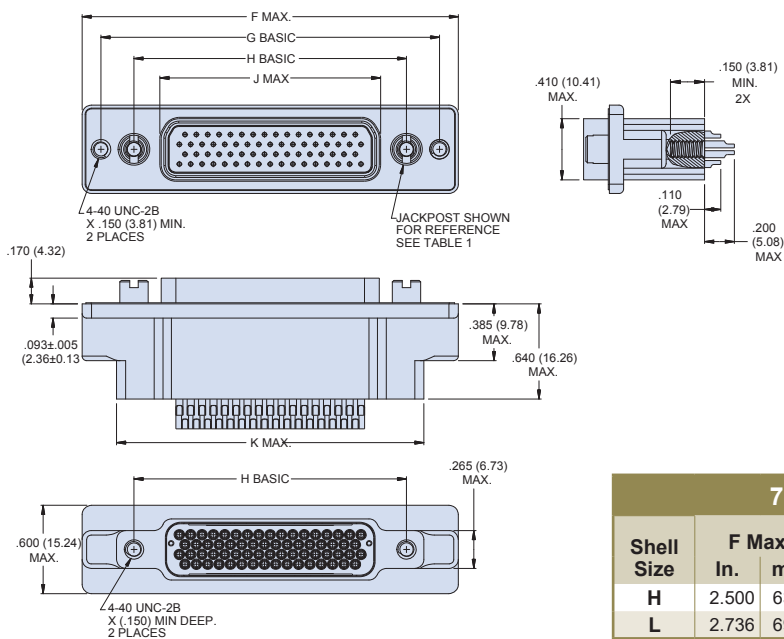

BLIND MATE

SHELL SIZES H, L
+/- .040 (1.02) ALLOWABLE
MISALIGNMENT
FROM CENTERLINE

790-071P SIZE H & L DIMENSIONS

Shell Size	F Max.		G Basic		H Basic		J Max.		K Max.	
	In.	mm.	In.	mm.	In.	mm.	In.	mm.	In.	mm.
H	2.500	63.50	2.236	56.79	1.800	45.72	1.450	36.83	2.045	51.94
L	2.736	69.49	2.472	62.79	2.036	51.71	1.686	42.82	2.281	57.94

Dimensions in Inches (millimeters) are subject to change without notice.

790-071P
Solder Cup Terminated Panel Mount Receptacles,
Pin Contacts
Dimensions



790-071P Shell Size M Dimensions

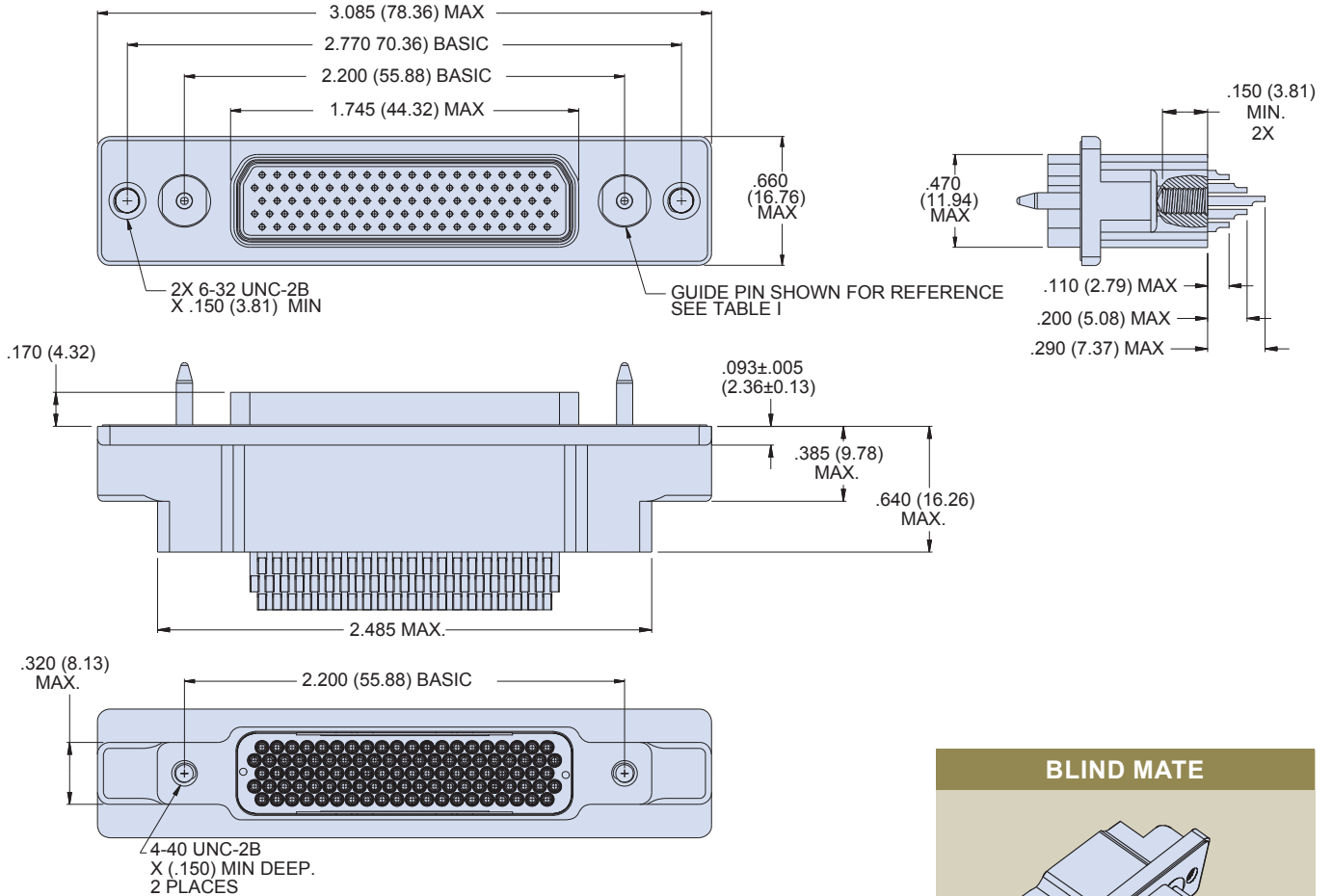

BLIND MATE

SHELL SIZE M
 +/- .050 (0.76) ALLOWABLE
 MISALIGNMENT FROM
 CENTERLINE

Dimensions in Inches (millimeters) are subject to change without notice.



790-072S
Solder Cup Terminated Panel Mount Plugs,
Socket Contacts
How To Order

790-072S Panel Mount Plugs

SOLDER CUP CONTACTS WITH CRIMP TERMINATION

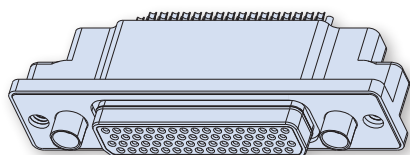

790-072S connectors are designed for rear-panel mounting and are supplied with conductive panel gaskets. These connectors feature machined aluminum shells. Contacts are rear-release snap-in solder cup type. Connectors are supplied with solder cup contacts packaged separately. Size #23 signal pins accept up to #22 AWG wire. Size #16 contacts accept #16-18 AWG wire. Size #12 contacts accept #12-14 AWG wire. Size 12 and 16 cavities also accept coaxial contacts purchased separately. Attach optional shielding adapters (799-016) for EMI protection.

HOW TO ORDER

Sample Part Number

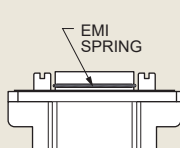
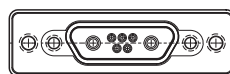
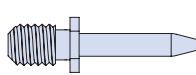
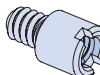
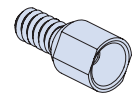
790-072S	H-66	M	E	P
Part Number	Shell Size - Insert Arr.	Shell Finish	EMI Spring	Hardware Option
790-072S Rear Panel Mounted Plug with Solder Cup Socket Contacts	See Table 1 for Available Insert Arrangements To order a connector without size #16 or #12 power pins, substitute "W" instead of "P" in the insert arrangement. Example: 36P2 is supplied with 2 power pins. 36W2 is supplied less the power pins. See Section B for coaxial contacts purchased separately.	M Electroless Nickel <i>general purpose applications</i> MT Nickel-PTFE 1000 Hour Grey™ <i>maximum corrosion protection and durability (non-reflective grey)</i> ZNU Zinc-Nickel with Black Chromate <i>tactical applications (non-reflective black)</i> Additional shell finishes are listed on page C-9.	E EMI Spring N No Spring  Note: EMI Spring is not compatible with chromate finishes including cadmium and zinc-nickel	 N No Hardware  G Guide Pin  P Female Jackpost  S Female Guide Socket

SPECIFICATIONS

Current Rating	#23 5 AMPS, #16 13 A., #12 23 A.
Dielectric Withstanding Voltage	#23 500 VAC RMS, #12 and #16 1800 VAC RMS
Insulation Resistance	5000 megohms minimum
Operating Temperature	-65° C. to +150° C.
Shock	300 g.
Vibration	37 g.

MATERIALS AND FINISHES

Shell	Aluminum alloy
Contacts	Copper alloy, 50 microinches gold plated, stainless steel hood
Insulators	Liquid crystal polymer (LCP)
Retention Clips	Beryllium copper alloy
Grommet	Fluorosilicone rubber
Hardware	300 series stainless steel
Panel Gasket	Fluorosilicone, conductive

Dimensions in Inches (millimeters) are subject to change without notice.

790-072S

Solder Cup Terminated Panel Mount Plugs, Socket Contacts

How To Order



Table 1 Contact Arrangements

Layout	Contact Quantity			Face View
	#23	#16	#12	
A-5	5			
B-2P2		2		
B-9	9			
C-13	13			
D-15	15			
D-3P3		3		
D-7P2	5	2		
E-11P2	9	2		
E-19	19			
E-7P3	4	3		
F-15P2	13	2		
F-23	23			
F-5P5		5		
G-33	33			
H-10P4	6	4		
H-29P7	22	7		
H-36P2	34	2		
H-54P2	52	2		
H-5P5		5		
H-66	66			
J-17P4	13	4		
J-25P2	23	2		
J-33	33			
J-7P7		7		
K-27P4	23	4		
K-35P2	33	2		
K-43	43			
K-9P9		9		
L-6P6		6		
L-78	78			
M-102	102			

CROSS-SECTIONAL VIEW OF 790-072S

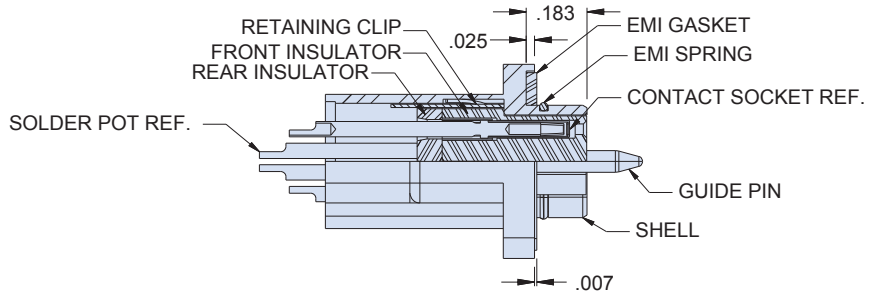
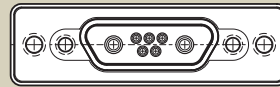

TABLE 2 HARDWARE OPTION



N

No Mating Hardware

Connector is supplied with threaded holes. Shell size M has #8-32 threads, shell sizes H and L have #6-32 threads, other sizes have #4-40 threads. Thread depth is .150" (3.8).

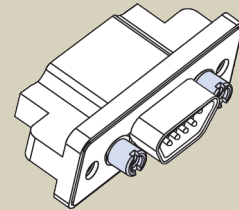

P

Jackposts

Connector is supplied with non-removable stainless steel jackposts. Shell size M has #6-32 threads, shell sizes H and L have #4-40 UNC thread, other sizes have #2-56 thread. Stainless steel.

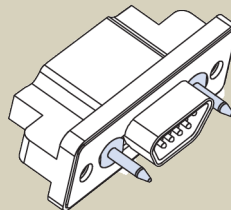

G

Guide Pins

Connector is supplied with stainless steel non-removable guide pins. Mates with type "S" guide sockets on corresponding receptacle connector.

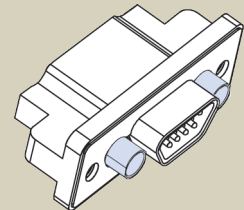

S

Guide Sockets

Connector is supplied with stainless steel non-removable bushings. Mates with type "G" guide pins on corresponding receptacle connector.

Dimensions in Inches (millimeters) are subject to change without notice.





790-072S
**Solder Cup Terminated Panel Mount Plugs,
Socket Contacts**
Dimensions

790-072S Shell Size A, B, C, D, E, F, J and K Dimensions

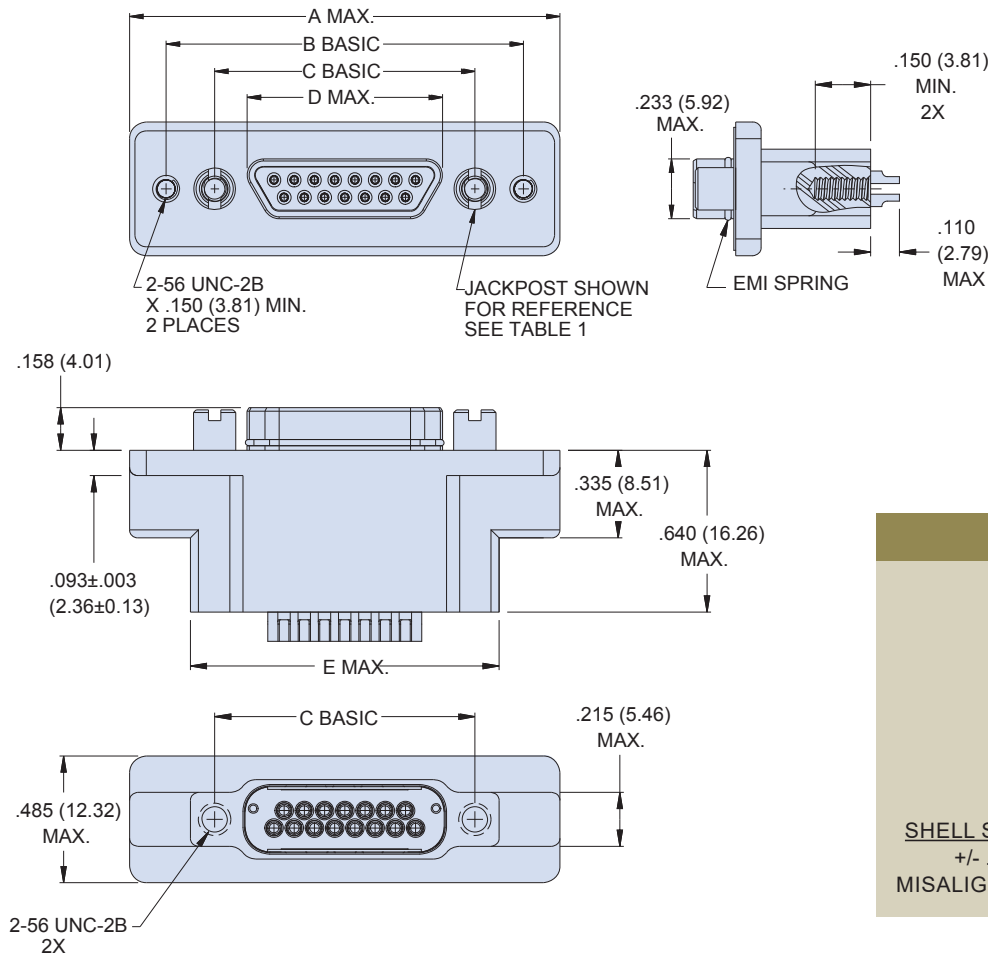

BLIND MATE

SHELL SIZES A, B, C, D, E, F, G, J, K
+/- .030 (0.76) ALLOWABLE
MISALIGNMENT FROM CENTERLINE

790-072S Shell Size A-F, J and K Dimensions

790-072S SIZE A-F, J, K DIMENSIONS										
Shell Size	A Max.		B Basic		C Basic		D Max.		E Max.	
	In.	mm.	In.	mm.	In.	mm.	In.	mm.	In.	mm.
A	1.211	30.76	.925	23.50	.565	14.35	.335	8.51	.760	19.30
B	1.361	34.57	1.075	27.31	.715	18.16	.485	12.32	.910	21.11
C	1.511	38.38	1.225	31.12	.865	21.97	.635	16.13	1.060	26.92
D	1.611	40.92	1.325	33.66	.965	24.51	.735	18.67	1.160	29.46
E	1.761	44.73	1.475	37.47	1.115	28.32	.885	22.48	1.310	33.27
F	1.911	48.54	1.625	41.28	1.265	32.13	1.035	26.29	1.460	37.08
J	2.261	57.43	1.975	50.17	1.615	41.02	1.390	35.31	1.810	45.97
K	2.661	67.59	2.375	60.33	2.015	51.18	1.795	45.59	2.210	56.13

Dimensions in Inches (millimeters) are subject to change without notice.

790-072S
**Solder Cup Terminated Panel Mount Plugs,
 Socket Contacts**
Dimensions



790-072S Shell Size G Dimensions

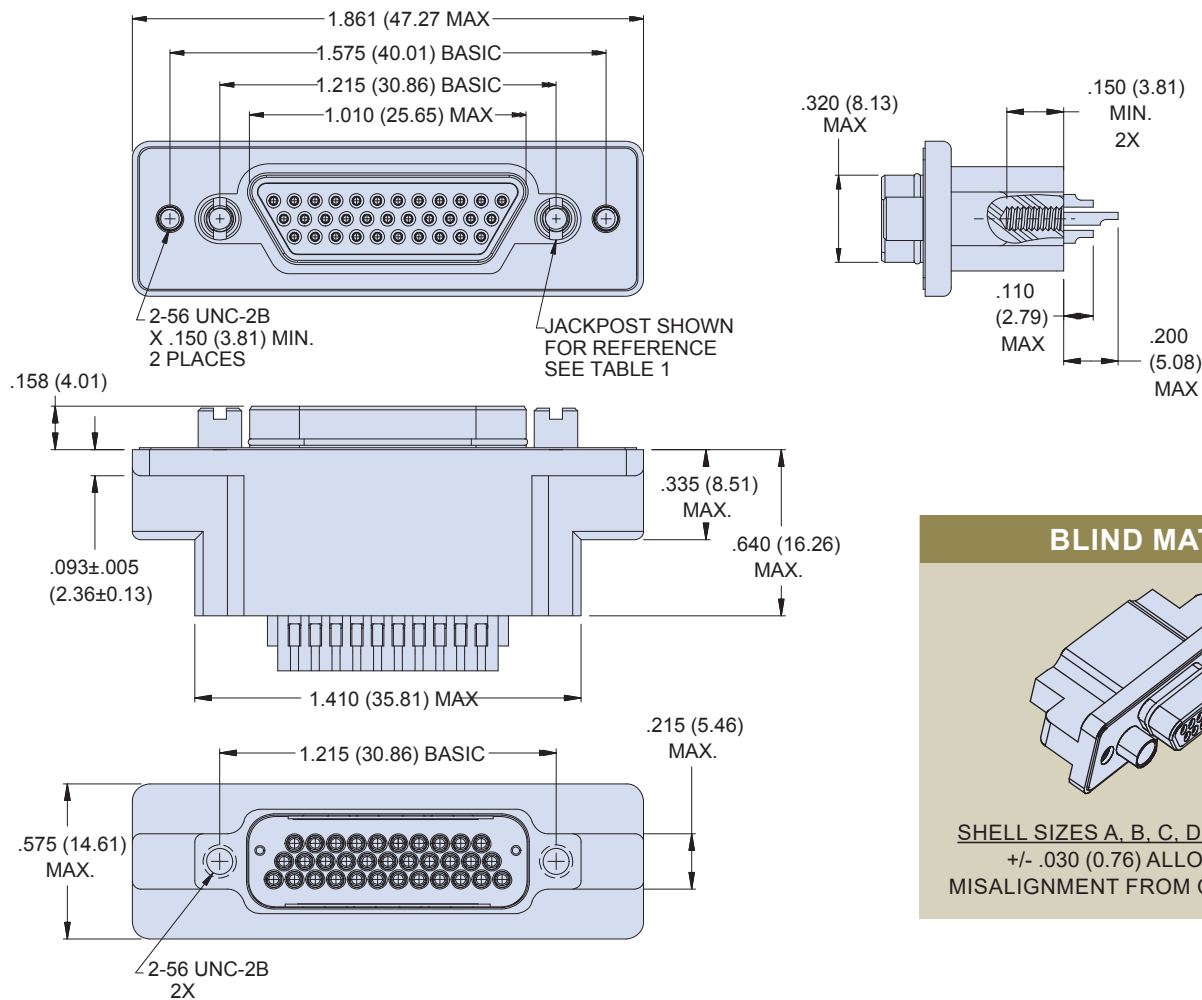

BLIND MATE

SHELL SIZES A, B, C, D, E, F, G, J, K
 +/- .030 (0.76) ALLOWABLE
 MISALIGNMENT FROM CENTERLINE

Dimensions in Inches (millimeters) are subject to change without notice.



790-072S Solder Cup Terminated Panel Mount Plugs, Socket Contacts Dimensions

790-072S Shell Size H and L Dimensions

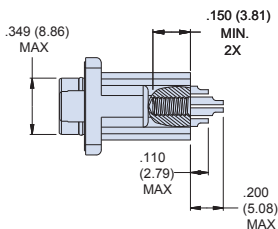
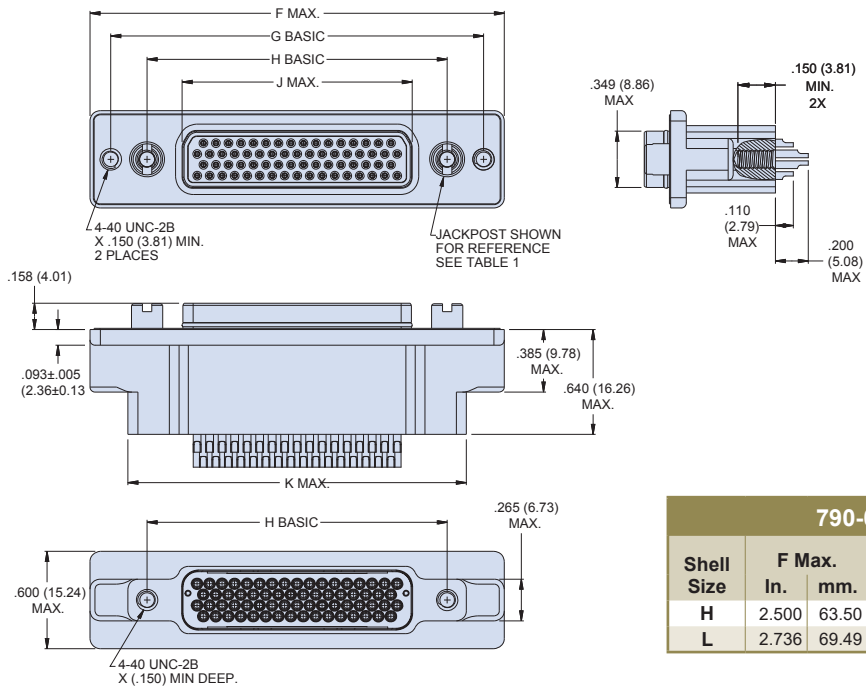

BLIND MATE

SHELL SIZES H, L
+/- .040 (1.02) ALLOWABLE MISALIGNMENT FROM CENTERLINE

790-072S SIZE H & L DIMENSIONS										
Shell Size	F Max.		G Basic		H Basic		J Max.		K Max.	
	In.	mm.	In.	mm.	In.	mm.	In.	mm.	In.	mm.
H	2.500	63.50	2.236	56.79	1.800	45.72	1.385	35.18	2.045	51.94
L	2.736	69.49	2.472	62.79	2.036	51.71	1.623	41.22	2.281	57.94

790-072S Shell Size M Dimensions

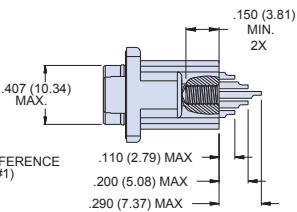
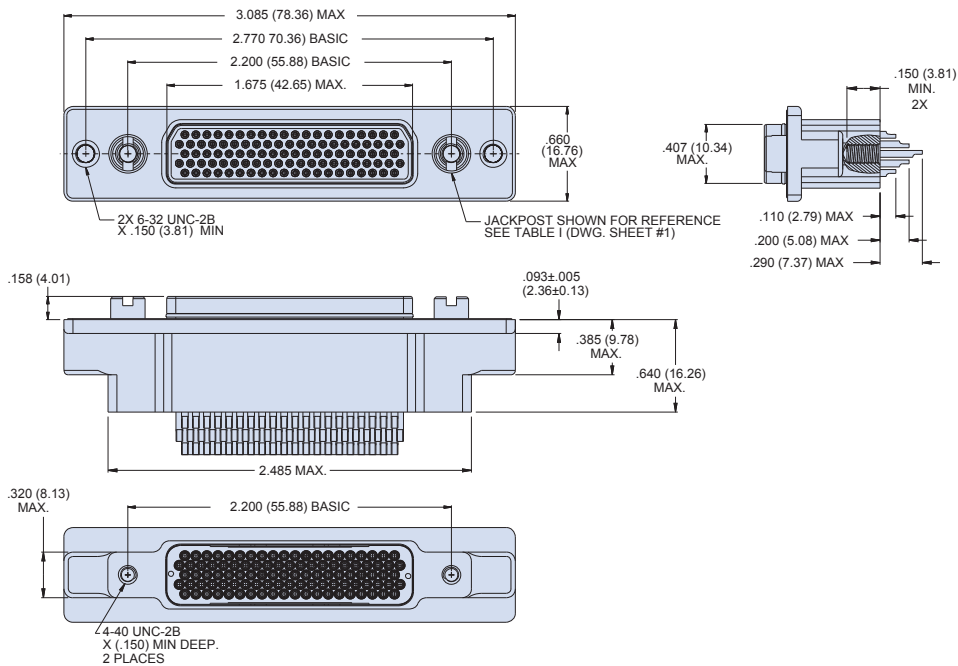

BLIND MATE

SHELL SIZE M
+/- .050 (0.76) ALLOWABLE MISALIGNMENT FROM CENTERLINE

Dimensions in Inches (millimeters) are subject to change without notice.

790-073P
Crimp Terminated Rear Panel
Float Mount Receptacles, Solder Cup Pin Contacts
How To Order



790-073P Rear Panel Float Mount Receptacles

SOLDER CUP PIN CONTACTS WITH CRIMP TERMINATION

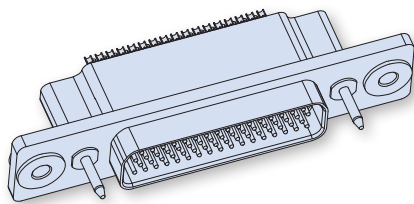

790-073P connectors are equipped with rear-panel float mounting assemblies to provide additional mounting leeway in rack and panel applications. These connectors feature machined aluminum shells and fluorosilicone face seals. Contacts are rear-release snap-in solder cup type. Connectors are supplied with solder cup contacts packaged separately. Size #23 signal pins accept up to #22 AWG wire. Size #16 contacts accept #16-18 AWG wire. Size #12 contacts accept #12-14 AWG wire. Size 12 and 16 cavities also accept coaxial contacts purchased separately. Attach optional shielding adapters (799-016) for EMI protection.

HOW TO ORDER

Sample Part Number

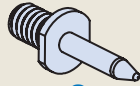
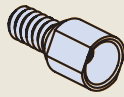
790-073P	H-66	M	P
Part Number	Shell Size - Insert Arrangements	Shell Finish	Hardware Option
<p>790-073P Rear Panel Float Mounted Receptacle with Solder Cup Pin Contacts</p>	<p>See Table I for Available Insert Arrangements</p> <p>To order a connector without size #16 or #12 power pins, substitute "W" instead of "P" in the insert arrangement.</p> <p>Example:</p> <p>36P2 is supplied with 2 power pins.</p> <p>36W2 is supplied less the power pins.</p> <p>See Section B for coaxial contacts purchased separately.</p>	<p style="text-align: center;">M Electroless Nickel <i>general purpose applications</i></p> <p style="text-align: center;">MT Nickel-PTFE 1000 Hour Grey™ <i>maximum corrosion protection and durability</i> <i>(non-reflective grey)</i></p> <p style="text-align: center;">ZNU Zinc-Nickel with Black Chromate <i>tactical applications</i> <i>(non-reflective black)</i></p> <p style="text-align: center;">Additional shell finishes are listed on page C-9.</p>	<div style="text-align: center;">  <p>N No Hardware</p>  <p>G Guide Pin</p>  <p>S Female Guide Socket</p> </div>

SPECIFICATIONS	
Current Rating	#23 5 AMPS, #16 13 A., #12 23 A.
Dielectric Withstanding Voltage	#23 500 VAC RMS, #12 and #16 1800 VAC RMS
Insulation Resistance	5000 megohms minimum
Operating Temperature	-65° C. to +150° C.
Shock	300 g.
Vibration	37 g.

MATERIALS AND FINISHES	
Shell	Aluminum alloy
Contacts	Copper alloy, 50 microinches gold plated, stainless steel hood
Insulators	Liquid crystal polymer (LCP)
Retention Clips	Beryllium copper alloy
Grommet	Fluorosilicone rubber
Hardware	300 series stainless steel

Dimensions in Inches (millimeters) are subject to change without notice.





790-073P

Crimp Terminated Rear Panel Float Mount Receptacles, Solder Cup Pin Contacts How To Order

Table 1 Contact Arrangements			
Layout	Contact Quantity		Face View
	#23	#16#12	
A-5	5		
B-2P2	2		
B-9	9		
C-13	13		
D-15	15		
D-3P3	3		
D-7P2	5	2	
E-11P2	9	2	
E-19	19		
E-7P3	4	3	
F-15P2	13	2	
F-23	23		
F-5P5	5		
G-33	33		
H-10P4	6	4	
H-29P7	22	7	
H-36P2	34	2	
H-54P2	52	2	
H-5P5		5	
H-66	66		
J-17P4	13	4	
J-25P2	23	2	
J-33	33		
J-7P7	7		
K-27P4	23	4	
K-35P2	33	2	
K-43	43		
K-9P9	9		
L-6P6		6	
L-78	78		
M-102	102		

CROSS-SECTIONAL VIEW OF 790-073P

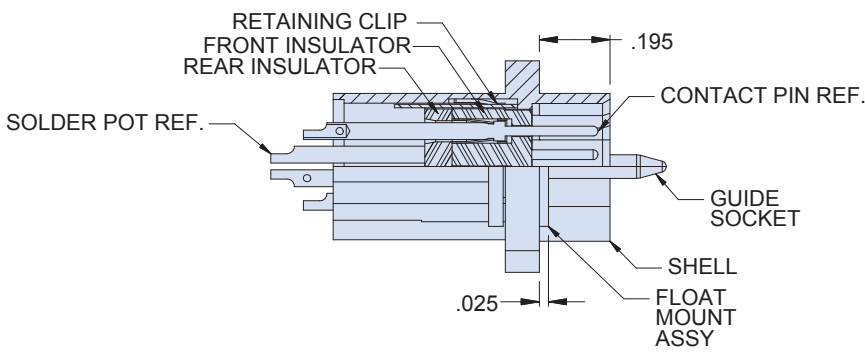

TABLE 2 HARDWARE OPTION

<p>N No Mating Hardware</p> <p>Connector is supplied with threaded holes. Shell size M has #8-32 threads, shell sizes H and L have #6-32 threads, other sizes have #4-40 threads. Thread depth is .150" (3.8).</p>	<p>G Guide Pins</p> <p>Connector is supplied with stainless steel non-removable guide pins. Mates with type "S" guide sockets on corresponding receptacle connector.</p>
<p>S Guide Sockets</p> <p>Connector is supplied with stainless steel non-removable bushings. Mates with type "G" guide pins on corresponding receptacle connector.</p>	

Dimensions in Inches (millimeters) are subject to change without notice.

790-073P
Crimp Terminated Rear Panel
Float Mount Receptacles, Solder Cup Pin Contacts
Dimensions



790-073P Shell Sizes A, B, C, D, E, F, J and K Dimensions

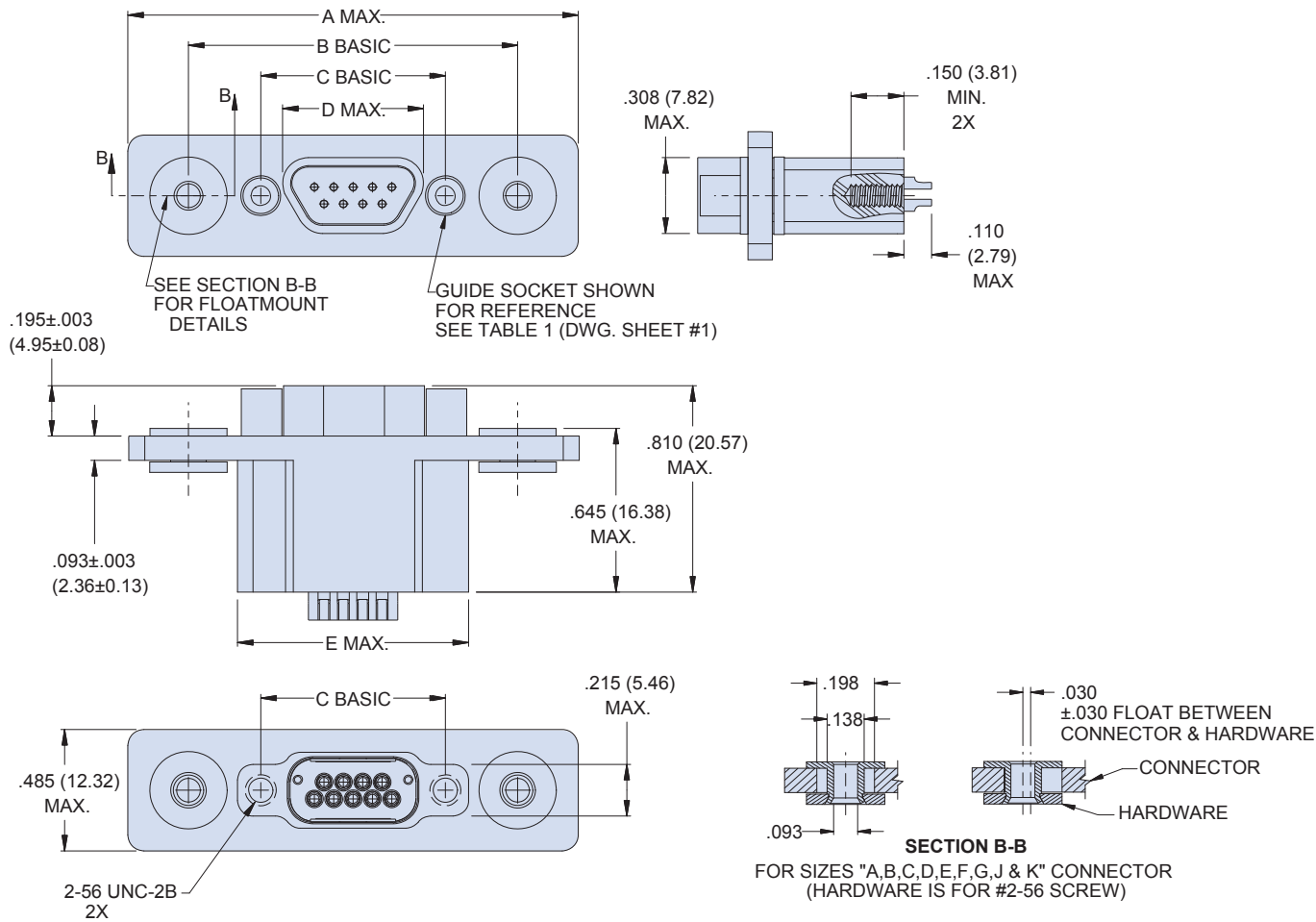

790-073P SIZES A, B, C, D, E, F, G, J & K DIMENSIONS

Shell Size	A Max.		B Basic		C Basic		D Max.		E Max.	
	In.	mm.	In.	mm.	In.	mm.	In.	mm.	In.	mm.
A	1.600	40.64	1.125	28.58	.565	14.35	.401	10.19	.760	19.30
B	1.700	43.18	1.275	32.38	.715	18.16	.551	14.00	.910	21.11
C	1.900	48.26	1.425	36.20	.865	21.97	.701	17.81	1.060	26.92
D	2.000	50.80	1.525	38.74	.965	25.51	.801	20.35	1.160	29.46
E	2.150	54.61	1.675	42.55	1.115	28.32	.951	24.16	1.310	33.27
F	2.300	58.42	1.825	46.36	1.265	32.13	1.101	27.96	1.460	37.08
J	2.650	67.31	2.175	55.25	1.615	41.02	1.456	36.98	1.810	45.97
K	3.050	77.47	2.575	65.41	2.015	51.18	1.860	47.24	2.210	56.13

BLIND MATE

SHELL SIZES A, B, C, D, E, F, G, J, K
 ±.030 (0.76) ALLOWABLE
 MISALIGNMENT FROM CENTERLINE

Dimensions in Inches (millimeters) are subject to change without notice.

790-073P Shell Size G Dimensions

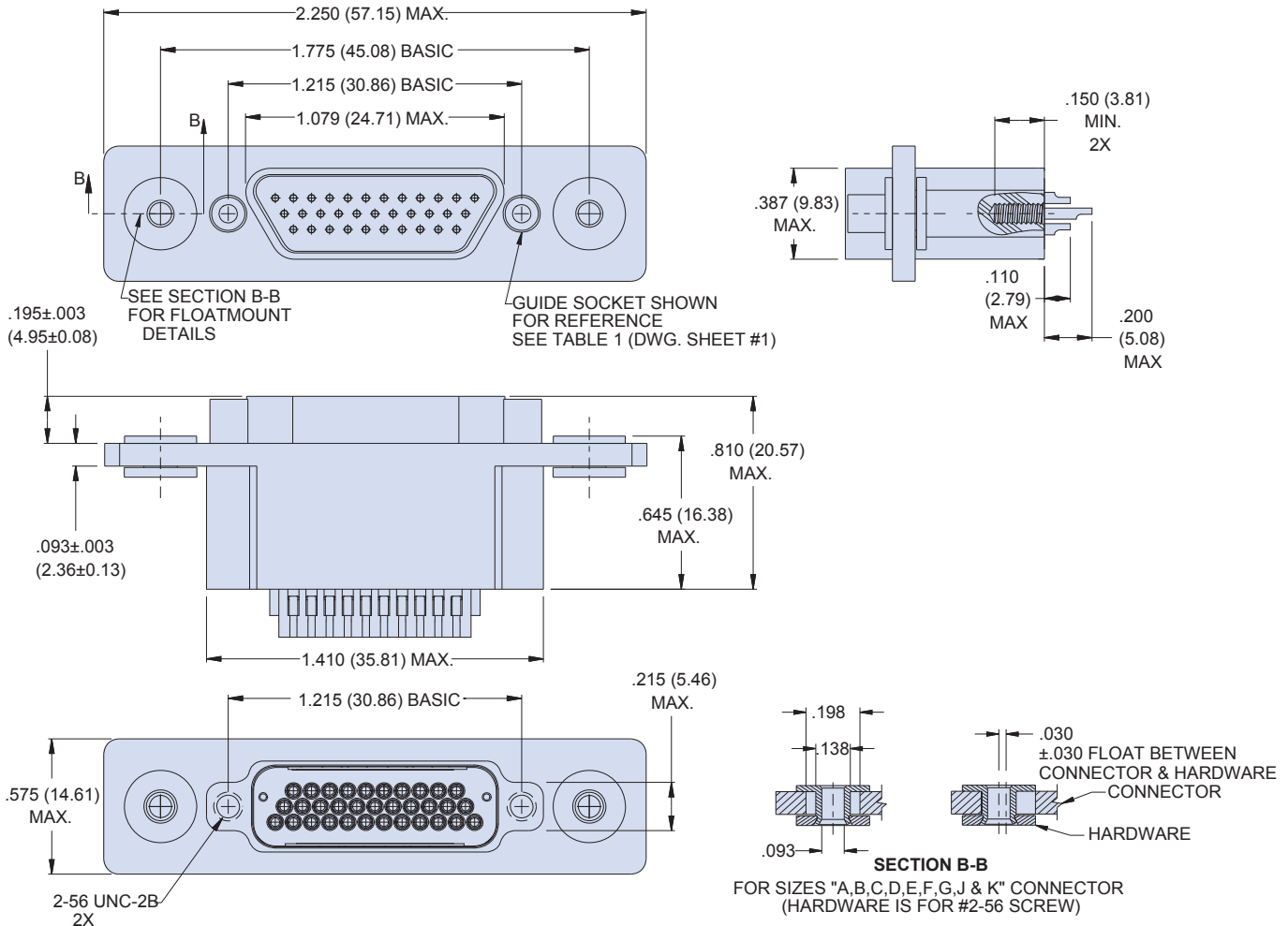

Dimensions in Inches (millimeters) are subject to change without notice.

790-073P
Crimp Terminated Rear Panel
Float Mount Receptacles, Solder Cup Pin Contacts
Dimensions



790-073P Shell Sizes H and L Dimensions

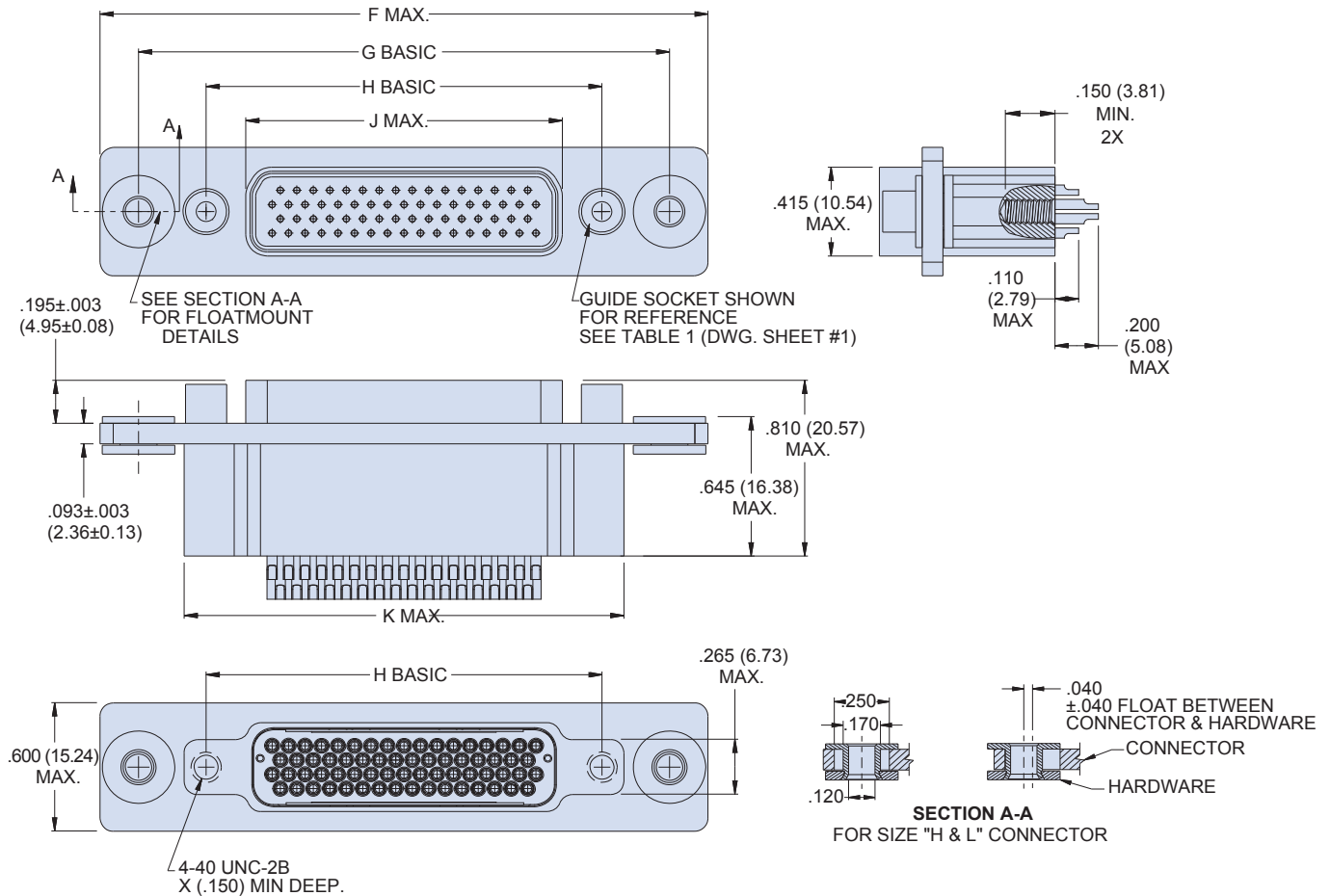

790-073P SIZES H & L DIMENSIONS										
Shell Size	A Max.		B Basic		C Basic		D Max.		E Max.	
	In.	mm.	In.	mm.	In.	mm.	In.	mm.	In.	mm.
H	2.780	70.61	2.415	61.34	1.800	45.72	1.450	36.83	2.045	51.94
L	3.016	76.61	2.651	67.34	2.036	51.71	1.686	42.82	2.281	57.94

BLIND MATE

SHELL SIZES H, L
 ±.040 (1.02) ALLOWABLE
 MISALIGNMENT FROM CENTERLINE

Dimensions in Inches (millimeters) are subject to change without notice.

790-074S
Solder Cup Terminated Rear Panel
Float Mount Plugs, Socket Contacts
How To Order



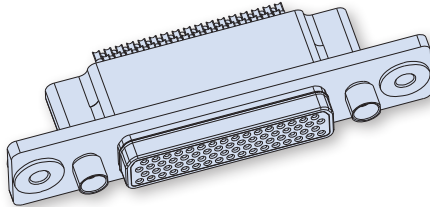

790-074S Rear Panel Float Mount Plugs SOCKET CONTACTS WITH CRIMP TERMINATION



790-074S connectors are equipped with rear-panel float mounting assemblies to provide additional mounting leeway in rack and panel applications. These connectors feature machined aluminum shells. Contacts are rear-release snap-in solder cup type. Connectors are supplied with solder cup contacts packaged separately. Size #23 signal pins accept up to #22 AWG wire. Size #16 contacts accept #16-18 AWG wire. Size #12 contacts accept #12-14 AWG wire. Size 12 and 16 cavities also accept coaxial contacts purchased separately. Attach optional shielding adapters (799-016) for EMI protection.

HOW TO ORDER

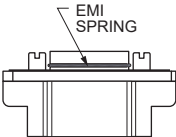
Sample Part Number

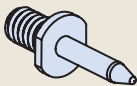
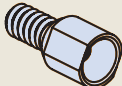
790-074S	H-66	M	E	P
Part Number	Shell Size - Insert Arrangements	Shell Finish	EMI Spring	Hardware Option
790-074S Rear Panel Float Mounted Receptacle with Socket Contacts	See Table I for Available Insert Arrangements To order a connector without size #16 or #12 power pins, substitute "W" instead of "P" in the insert arrangement. Example: 36P2 is supplied with 2 power pins. 36W2 is supplied less the power pins. See Section B for coaxial contacts purchased separately.	M Electroless Nickel <i>general purpose applications</i> MT Nickel-PTFE <i>1000 Hour Grey™</i> <i>maximum corrosion</i> <i>protection and durability</i> <i>(non-reflective grey)</i> ZNU Zinc-Nickel with Black Chromate <i>tactical applications</i> <i>(non-reflective black)</i> Additional shell finishes are listed on page C-9.	E EMI Spring N No Spring  Note: EMI Spring is not compatible with chromate finishes including cadmium and zinc-nickel	 N No Hardware  G Guide Pin  S Female Guide Socket

SPECIFICATIONS

Current Rating	#23 5 AMPS, #16 13 A., #12 23 A.
Dielectric Withstanding Voltage	#23 500 VAC RMS, #12 and #16 1800 VAC RMS
Insulation Resistance	5000 megohms minimum
Operating Temperature	-65° C. to +150° C.
Shock	300 g.
Vibration	37 g.

MATERIALS AND FINISHES

Shell	Aluminum alloy
Contacts	Copper alloy, 50 microinches gold plated, stainless steel hood
Insulators	Liquid crystal polymer (LCP)
Retention Clips	Beryllium copper alloy
Grommet	Flourosilicone rubber
Hardware	300 series stainless steel

Dimensions in Inches (millimeters) are subject to change without notice.



790-074S

Solder Cup Terminated Rear Panel Float Mount Plugs, Socket Contacts

How To Order

Table 1 Contact Arrangements

Layout	Contact Quantity		Face View
	#23	#16#12	
A-5	5		
B-2P2	2		
B-9	9		
C-13	13		
D-15	15		
D-3P3	3		
D-7P2	5	2	
E-11P2	9	2	
E-19	19		
E-7P3	4	3	
F-15P2	13	2	
F-23	23		
F-5P5	5		
G-33	33		
H-10P4	6	4	
H-29P7	22	7	
H-36P2	34	2	
H-54P2	52	2	
H-5P5		5	
H-66	66		
J-17P4	13	4	
J-25P2	23	2	
J-33	33		
J-7P7	7		
K-27P4	23	4	
K-35P2	33	2	
K-43	43		
K-9P9	9		
L-6P6		6	
L-78	78		
M-102	102		

CROSS-SECTIONAL VIEW OF 790-074S

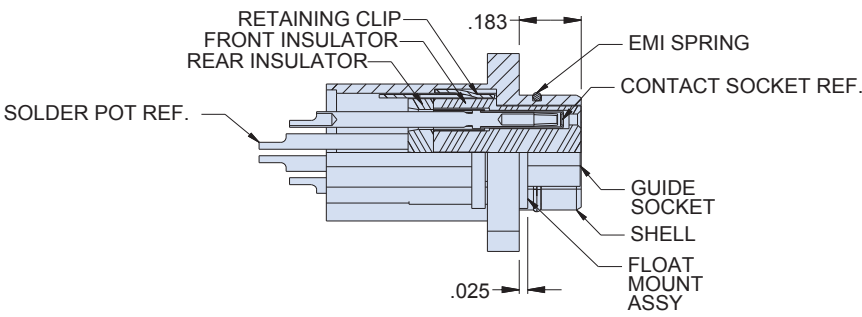

TABLE 2 HARDWARE OPTION

N

No Mating Hardware

Connector is supplied with threaded holes. Shell size M has #8-32 threads, shell sizes H and L have #6-32 threads, other sizes have #4-40 threads. Thread depth is .150" (3.8).

G

Guide Pins

Connector is supplied with stainless steel non-removable guide pins. Mates with type "S" guide sockets on corresponding receptacle connector.

S

Guide Sockets

Connector is supplied with stainless steel non-removable bushings. Mates with type "G" guide pins on corresponding receptacle connector.

Dimensions in Inches (millimeters) are subject to change without notice.

790-074S
Solder Cup Terminated Rear Panel
Float Mount Plugs, Socket Contacts
Dimensions



790-074S Shell Sizes A, B, C, D, E, F, J and K Dimensions

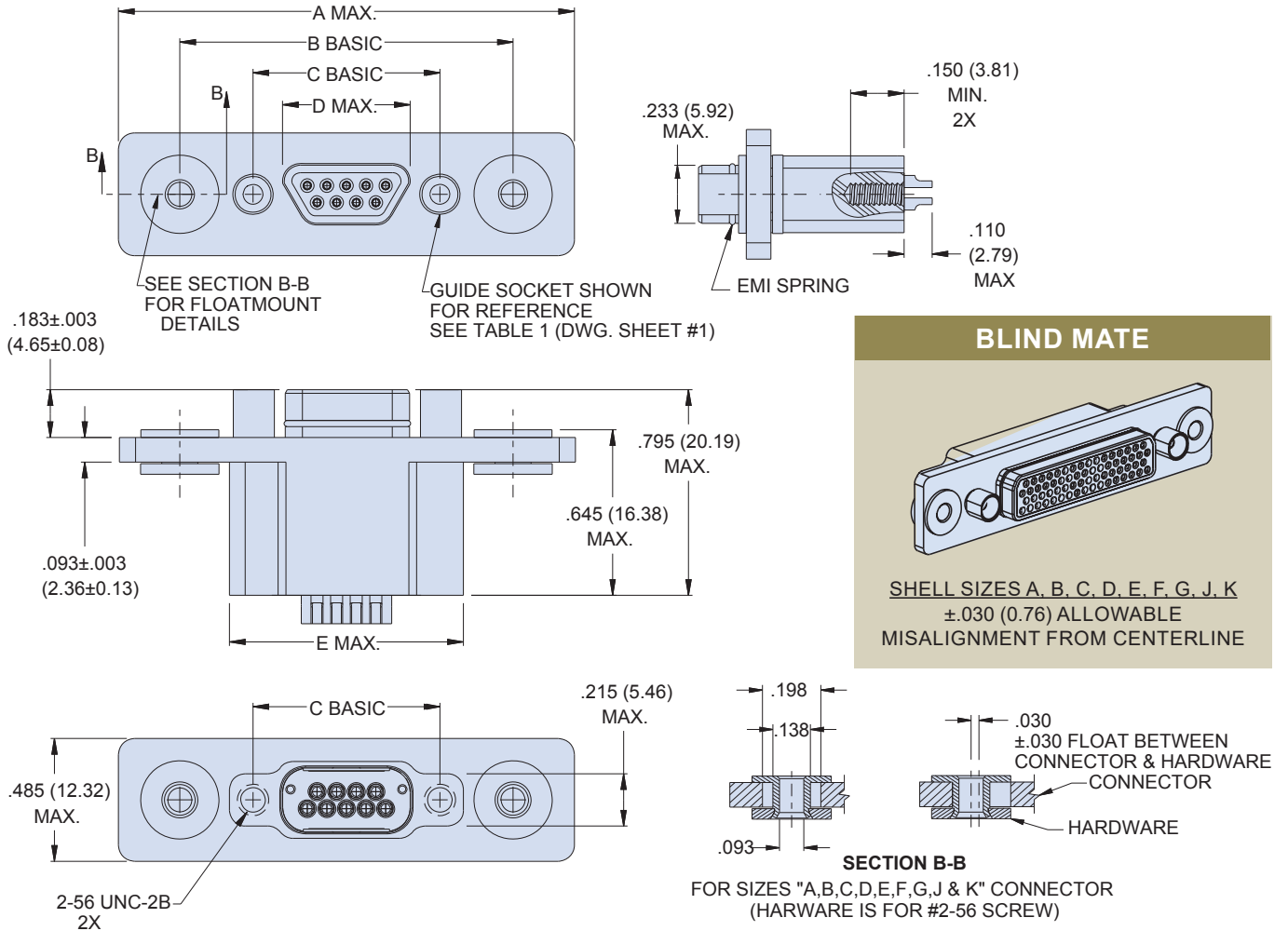

790-074S SIZES A, B, C, D, E, F, G, J & K DIMENSIONS										
Shell Size	A Max.		B Basic		C Basic		D Max.		E Max.	
	In.	mm.	In.	mm.	In.	mm.	In.	mm.	In.	mm.
A	1.600	40.64	1.125	28.58	.565	14.35	.335	8.51	.760	19.30
B	1.700	43.18	1.275	32.38	.715	18.16	.485	12.32	.910	21.11
C	1.900	48.26	1.425	36.20	.865	21.97	.635	16.13	1.060	26.92
D	2.000	50.80	1.525	38.74	.965	25.51	.735	18.67	1.160	29.46
E	2.150	54.61	1.675	42.55	1.115	28.32	.885	22.48	1.310	33.27
F	2.300	58.42	1.825	46.36	1.265	32.13	1.035	26.29	1.460	37.08
J	2.650	67.31	2.175	55.25	1.615	41.02	1.390	35.31	1.810	45.97
K	3.050	77.47	2.575	65.41	2.015	51.18	1.795	45.59	2.210	56.13

Dimensions in Inches (millimeters) are subject to change without notice.

790-074S
Solder Cup Terminated Rear Panel
Float Mount Plugs, Socket Contacts
Dimensions



790-074S Shell Sizes H and L Dimensions

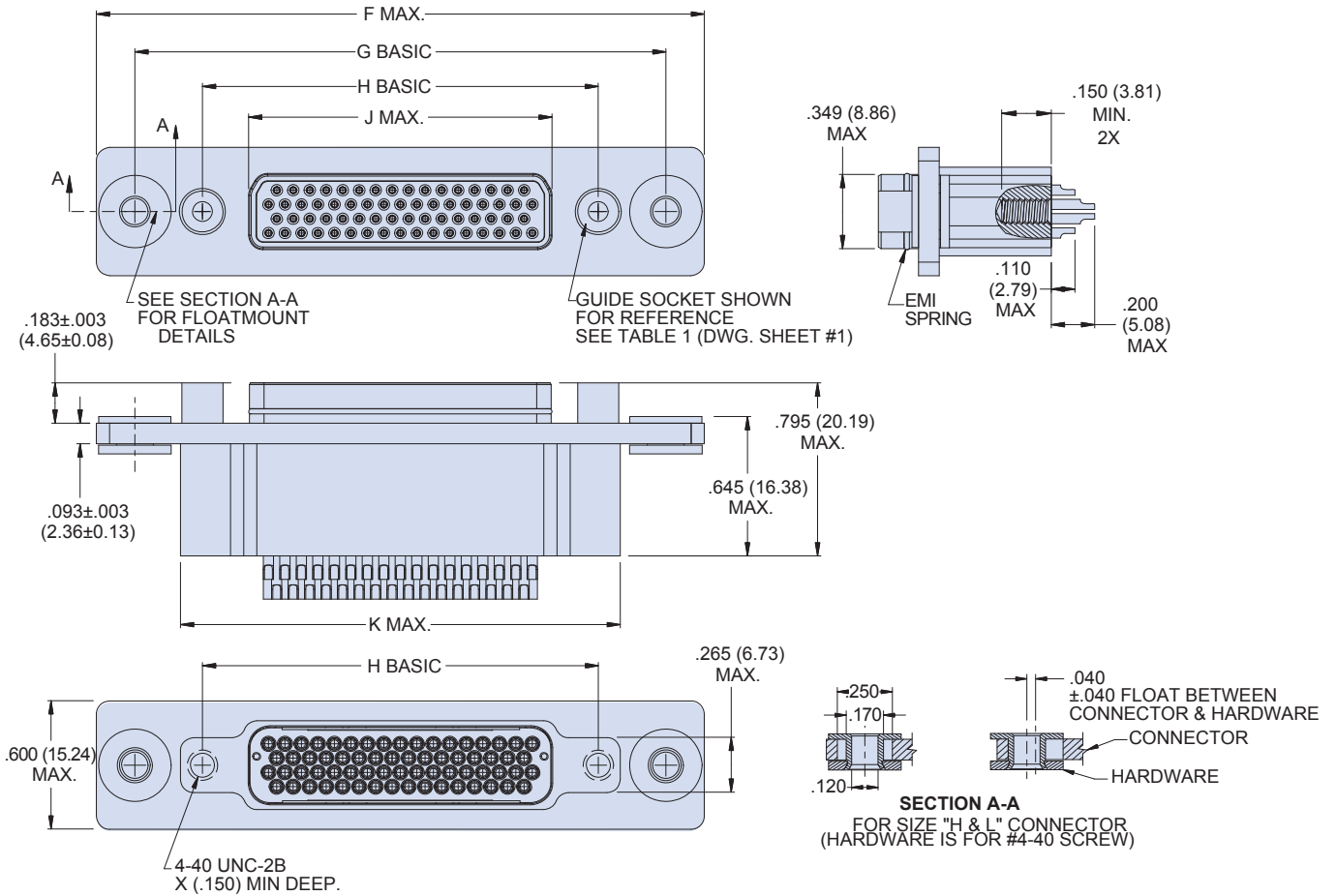

790-050P SIZES H & L DIMENSIONS

Shell Size	F Max.		G Basic		H Basic		J Max.		K Max.	
	In.	mm.	In.	mm.	In.	mm.	In.	mm.	In.	mm.
H	2.780	70.61	2.415	61.34	1.800	45.72	1.385	35.18	2.045	51.94
L	3.016	76.61	2.651	67.34	2.036	51.71	1.623	41.22	2.281	57.94

BLIND MATE

SHELL SIZES H, L
 ±.040 (1.02) ALLOWABLE
 MISALIGNMENT FROM CENTERLINE

Dimensions in Inches (millimeters) are subject to change without notice.



790-074S
Solder Cup Terminated Rear Panel
Float Mount Plugs, Socket Contacts
Dimensions

790-074S Shell Size M Dimensions

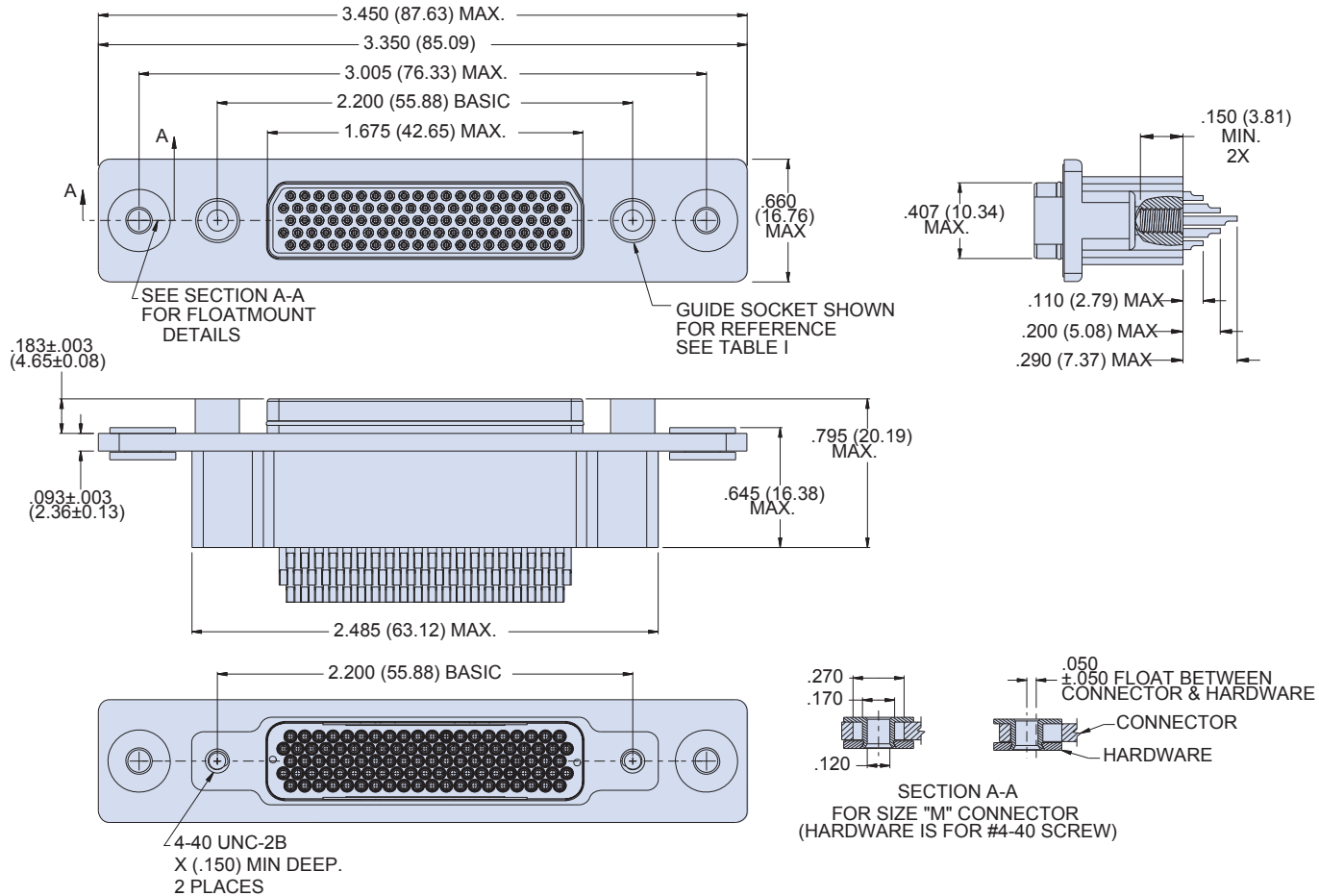

BLIND MATE

SHELL SIZE M
±.050 (1.27) ALLOWABLE
MISALIGNMENT FROM CENTERLINE

Dimensions in Inches (millimeters) are subject to change without notice.

790-028P
Straight PCB Terminated
Panel Mount Receptacle, Pin Contacts
How To Order



790-028P Straight PCB Panel Mount Receptacle
PIN CONTACTS WITH STRAIGHT PCB TERMINATION

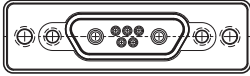
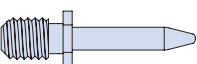
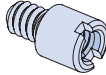
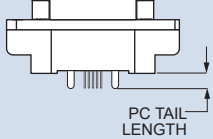
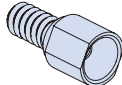

790-028P connectors are designed for rear-panel mounting and are supplied with conductive panel gaskets. These connectors feature machined aluminum shells, fluorosilicone face seals and straight printed circuit board contacts. Contacts are epoxy-encapsulated and are non-removable. Contacts are gold plated. Connector shells provide blind threaded holes for attaching to panel and to printed circuit board. Available in 29 different insert arrangements, these connectors feature size #23 contacts for signal and data. For higher current applications, size #16 contacts provide up to 13 amps and size #12 contacts handle up to 23 amps.

HOW TO ORDER				
Sample Part Number				
790-028P	J-25P2	M	P	A
Part Number	Shell Size - Insert Arrangements	Shell Finish	Hardware Option	PC Tail Length
790-028P Rear Panel Mounted Receptacle with PC Tail Pin Contacts for Termination to Backplanes or Flexible Circuits	See Table 1 for Available Insert Arrangements	M Electroless Nickel <i>general purpose applications</i>	 N No Hardware	A .125 Inch (3.2 mm.)
		MT Nickel-PTFE 1000 Hour Grey™ <i>maximum corrosion protection and durability (non-reflective grey)</i>	 G Guide Pin	B .250 inch (6.4 mm.)
		ZNU Zinc-Nickel with Black Chromate <i>tactical applications (non-reflective black)</i>	 P Female Jackpost	 PC TAIL LENGTH
		Additional shell finishes are listed on page C-9.	 S Female Guide Socket	

SPECIFICATIONS	
Current Rating	#23 5 AMPS, #16 13 A., #12 23 A.
Dielectric Withstanding Voltage	#23 500 VAC RMS, #12 and #16 1800 VAC RMS
Insulation Resistance	5000 megohms minimum
Operating Temperature	-65° C. to +150° C.
Shock	300 g.
Vibration	37 g.

MATERIALS AND FINISHES	
Shell	Aluminum alloy
Contacts	Copper alloy, 50 microinches gold plated
Insulators	Liquid crystal polymer (LCP)
Retention Clips	Beryllium copper alloy
Interfacial Seal	Flourosilicone rubber
Hardware	300 series stainless steel
Panel Gasket	Fluorosilicone, conductive
Encapsulant	Epoxy

Dimensions in Inches (millimeters) are subject to change without notice.

Table Contact Arrangements

Layout	Contact Quantity			Face View
	#23	#16	#12	
A-5	5			
B-2P2		2		
B-9	9			
C-13	13			
D-15	15			
D-3P3		3		
D-7P2	5	2		
E-11P2	9	2		
E-19	19			
E-7P3	4	3		
F-15P2	13	2		
F-23	23			
F-5P5		5		
G-33	33			
H-10P4	6		4	
H-29P7	22		7	
H-36P2	34		2	
H-54P2	52		2	
H-5P5			5	
H-66	66			
J-17P4	13		4	
J-25P2	23		2	
J-33	33			
J-7P7			7	
K-27P4	23		4	
K-35P2	33		2	
K-43	43			
K-9P9			9	
L-6P6			6	
L-78	78			
M-102	102			

CROSS-SECTIONAL VIEW OF 790-028P

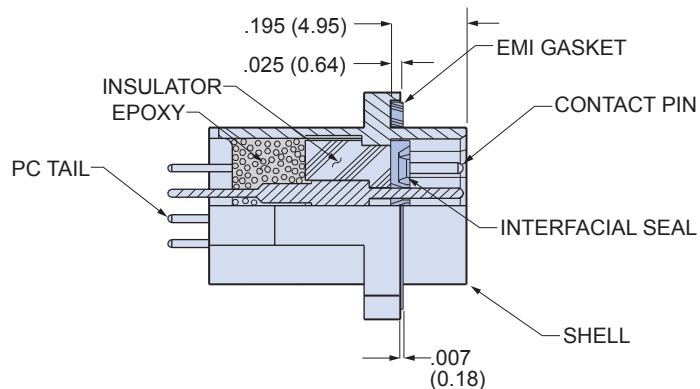
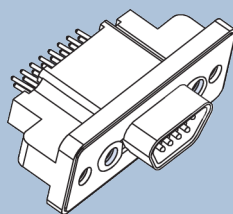

TABLE 2 HARDWARE OPTION



N

No Mating Hardware

Connector is supplied with threaded holes. Shell size M has #8-32 threads, shell sizes H and L have #6-32 threads, other sizes have #4-40 threads. Thread depth is .150" (3.8).

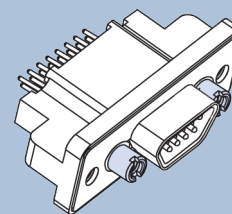

P

Jackposts

Connector is supplied with non-removable stainless steel jackposts. Shell size M has #6-32 threads, shell sizes H and L have #4-40 UNC thread, other sizes have #2-56 thread.

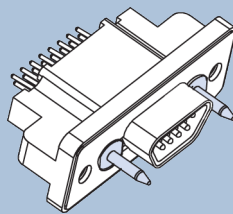

G

Guide Pins

Connector is supplied with stainless steel non-removable guide pins. Mates with type "S" guide sockets on corresponding plug connector.

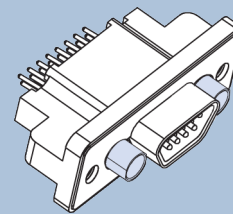

S

Guide Sockets

Connector is supplied with stainless steel non-removable bushings. Mates with type "G" guide pins on corresponding plug connector.

Dimensions in Inches (millimeters) are subject to change without notice.

790-028P
Straight PCB Terminated
Panel Mount Receptacle, Pin Contacts
Dimensions



790-028P Shell Size A, B, C, D, E, F, J and K Dimensions

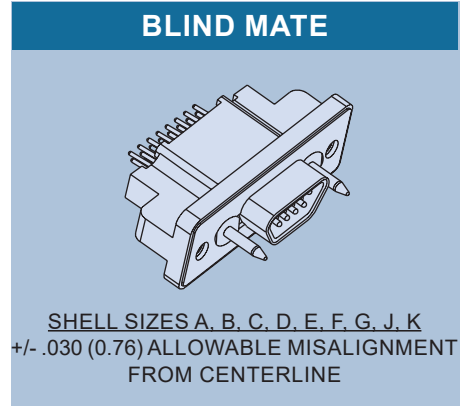
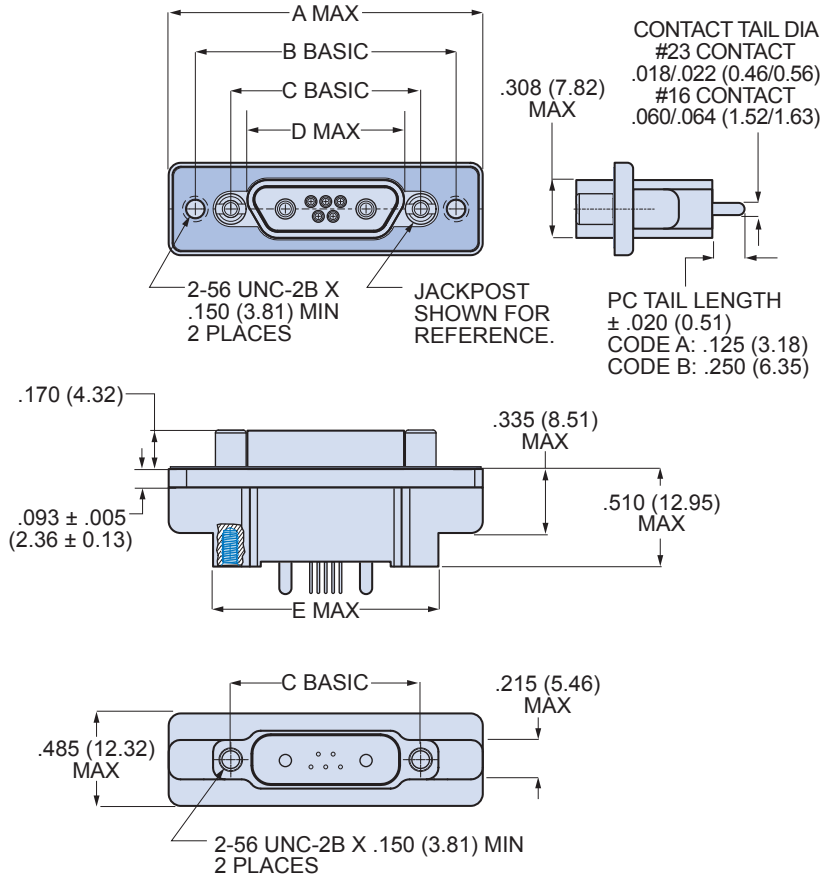

790-028P DIMENSIONS FOR SIZE A-F, J AND K										
Shell Size	A Max.		B Basic		C Basic		D Max.		E Max.	
	In.	mm.	In.	mm.	In.	mm.	In.	mm.	In.	mm.
A	1.211	30.76	.925	23.50	.565	14.35	.401	10.19	.760	19.30
B	1.361	34.57	1.075	27.31	.715	18.16	.551	14.00	.910	21.11
C	1.511	38.38	1.225	31.12	.865	21.97	.701	17.81	1.060	26.92
D	1.611	40.92	1.325	33.66	.965	24.51	.801	20.35	1.160	29.46
E	1.761	44.73	1.475	37.47	1.115	28.32	.951	24.16	1.310	33.27
F	1.911	48.54	1.625	41.28	1.265	32.13	1.101	27.96	1.460	37.08
J	2.261	57.43	1.975	50.17	1.615	41.02	1.460	37.08	1.810	45.97
K	2.661	67.59	2.375	60.33	2.015	51.18	1.860	47.24	2.210	56.13

Dimensions in Inches (millimeters) are subject to change without notice.

790-028P Straight PCB Terminated Panel Mount Receptacle, Pin Contacts Dimensions



790-028P Shell Size H and L Dimensions

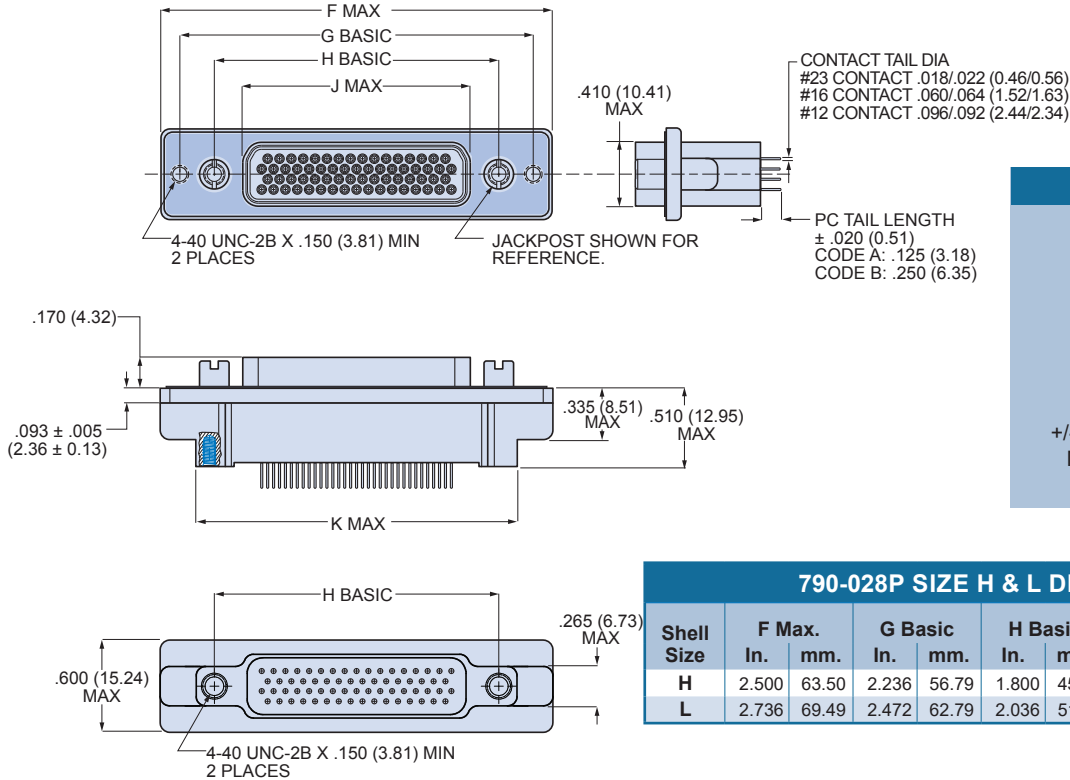

BLIND MATE

SHELL SIZES H, L
+/- .040 (1.02) ALLOWABLE MISALIGNMENT FROM CENTERLINE

790-028P Shell Size M Dimensions

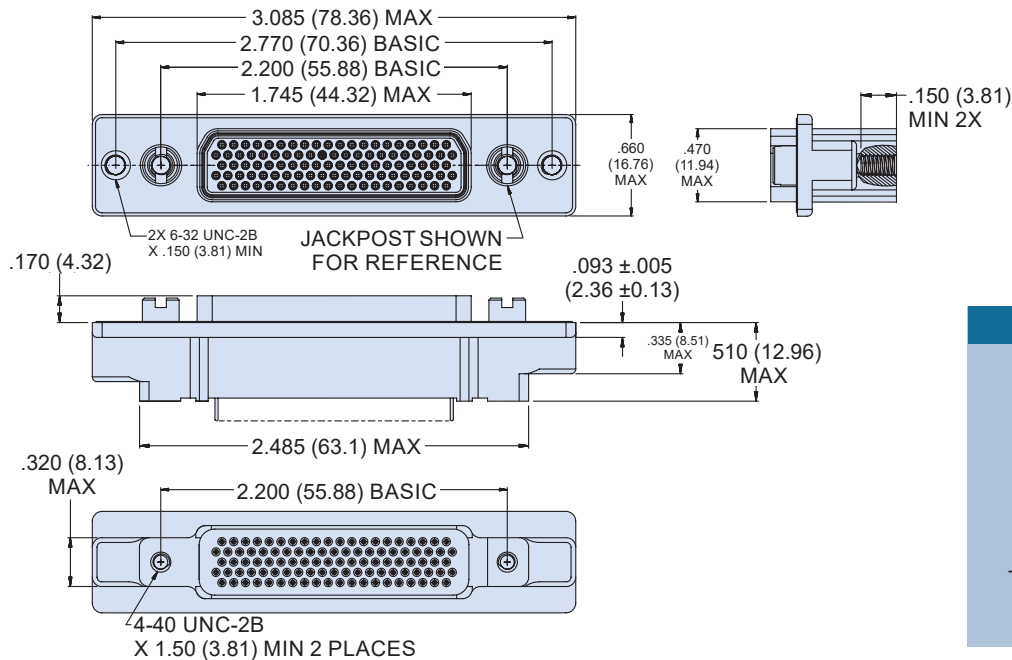

BLIND MATE

SHELL SIZE M
+/- .050 (1.27) ALLOWABLE MISALIGNMENT FROM CENTERLINE

Dimensions in Inches (millimeters) are subject to change without notice.



790-043P
Straight PCB Terminated
Free-Standing Receptacle, Pin Contacts
How To Order

790-043P Straight PCB Free-Standing Receptacles
PIN CONTACTS WITH STRAIGHT PCB TERMINATION

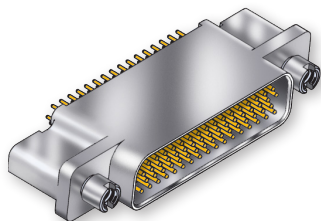

790-043P connectors feature thru-hole termination to rigid or flexible circuits. These free-standing vertical mount headers mate with 790-025S cable connectors. 29 contact arrangements include size #16 and #12 power contacts for maximum design flexibility. Contacts are epoxy encapsulated and are non-removable. Fluorosilicone face seal provides watertight sealing when mated. One-piece machined aluminum shell has threaded holes for board attachment.

HOW TO ORDER

Sample Part Number

790-043P

K-9P9

M

P

A

Part Number

**Shell Size -
Insert
Arrangements**

Shell Finish

Hardware Option

PC Tail Length

790-043P

Receptacle with Straight
PC Tail Pin Contacts for
Termination to Backplanes
or Flexible Circuits

See Table 1 for
Available Insert
Arrangements

M

Electroless Nickel
general purpose applications

MT

Nickel-PTFE
1000 Hour Grey™
*maximum corrosion protection
and durability
(non-reflective grey)*

ZNU

Zinc-Nickel with Black
Chromate
*tactical applications
(non-reflective black)*

Additional shell finishes are
listed on page C-9.

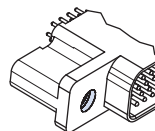

N

No Hardware

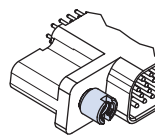

P

Female Jackpost

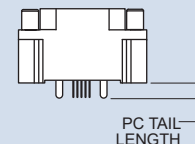

A
.125 Inch (3.2 mm.)

B
.250 inch (6.4 mm.)

SPECIFICATIONS

Current Rating	#23 5 AMPS, #16 13 A., #12 23 A.
Dielectric Withstanding Voltage	#23 500 VAC RMS, #12 and #16 1800 VAC RMS
Insulation Resistance	5000 megohms minimum
Operating Temperature	-65° C. to +150° C.
Shock	300 g.
Vibration	37 g.

MATERIALS AND FINISHES

Shell	Aluminum alloy
Contacts	Copper alloy, 50 microinches gold plated
Insulators	Liquid crystal polymer (LCP)
Interfacial Seal	Flourosilicone rubber
Jackpost	300 series stainless steel
Encapsulant	Epoxy

Dimensions in Inches (millimeters) are subject to change without notice.

790-043P
Straight PCB Terminated
Free-Standing Receptacle, Pin Contacts
How To Order



Table 1 Contact Arrangements

Layout	Contact Quantity			Face View
	#23	#16	#12	
A-5	5			
B-2P2		2		
B-9	9			
C-13	13			
D-15	15			
D-3P3		3		
D-7P2	5	2		
E-11P2	9	2		
E-19	19			
E-7P3	4	3		
F-15P2	13	2		
F-23	23			
F-5P5		5		
G-33	33			
H-10P4	6	4		
H-29P7	22	7		
H-36P2	34	2		
H-54P2	52	2		
H-5P5			5	
H-66	66			
J-17P4	13	4		
J-25P2	23	2		
J-33	33			
J-7P7		7		
K-27P4	23	4		
K-35P2	33	2		
K-43	43			
K-9P9		9		
L-6P6			6	
L-78	78			
M-102	102			

CROSS-SECTIONAL VIEW OF 790-043P

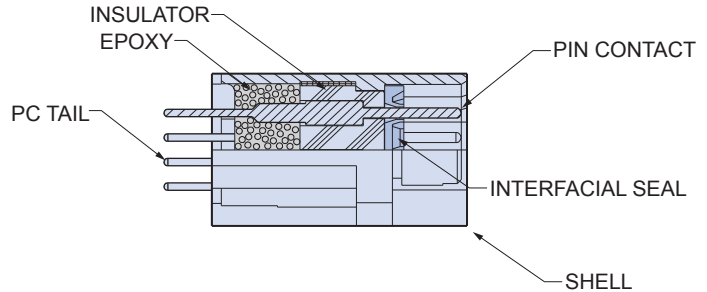
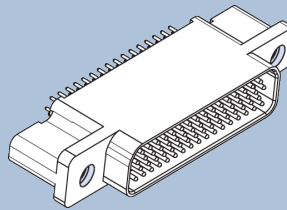

TABLE 2 HARDWARE OPTION



N

No Mating Hardware

Connector is supplied with threaded holes. Shell size M has #8-32 threads, shell sizes H and L have #6-32 threads, other sizes have #4-40 threads. Thread depth is .150" (3.8).

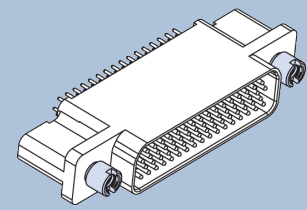

P

Jackposts

Connector is supplied with non-removable stainless steel jackposts. Shell size M has #6-32 threads, shell sizes H and L have #4-40 UNC thread, other sizes have #2-56 thread.

Dimensions in Inches (millimeters) are subject to change without notice.

790-043P Shell Size A-G, J and K Dimensions

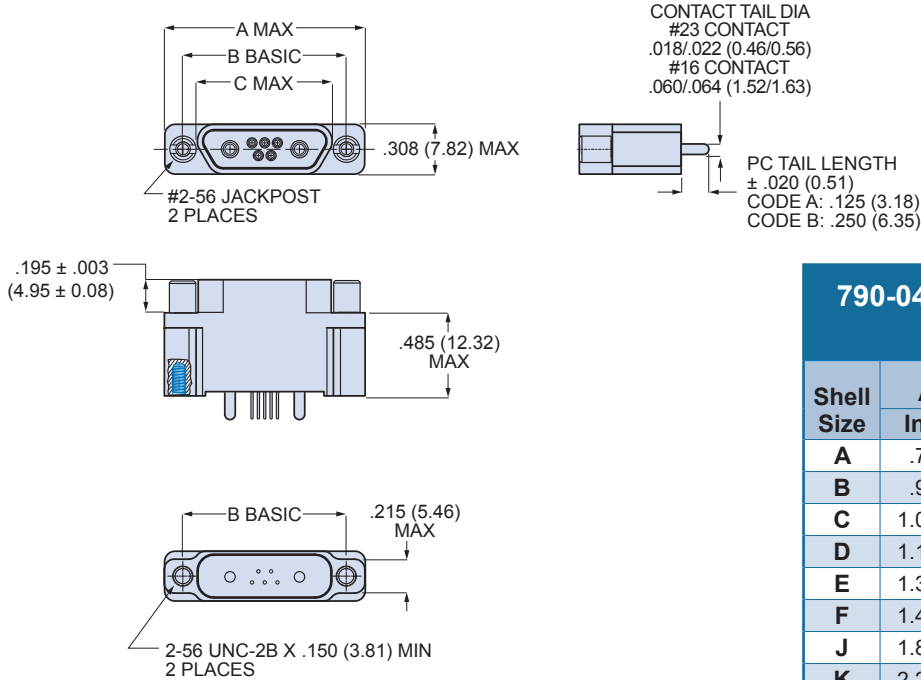

790-043P SHELL SIZE A-K, J & K DIMENSIONS						
Shell Size	A Max.		B Basic		C Max.	
	In.	mm.	In.	mm.	In.	mm.
A	.785	19.94	.565	14.35	.400	10.16
B	.935	23.75	.715	18.16	.551	14.00
C	1.085	27.56	.865	21.97	.701	17.81
D	1.185	30.10	.965	24.51	.801	20.35
E	1.335	33.91	1.115	28.32	.951	24.16
F	1.485	37.72	1.265	32.13	1.101	27.96
J	1.845	46.86	1.615	41.02	1.460	37.08
K	2.240	56.90	2.015	51.18	1.860	47.24

790-043P Shell Size G Dimensions

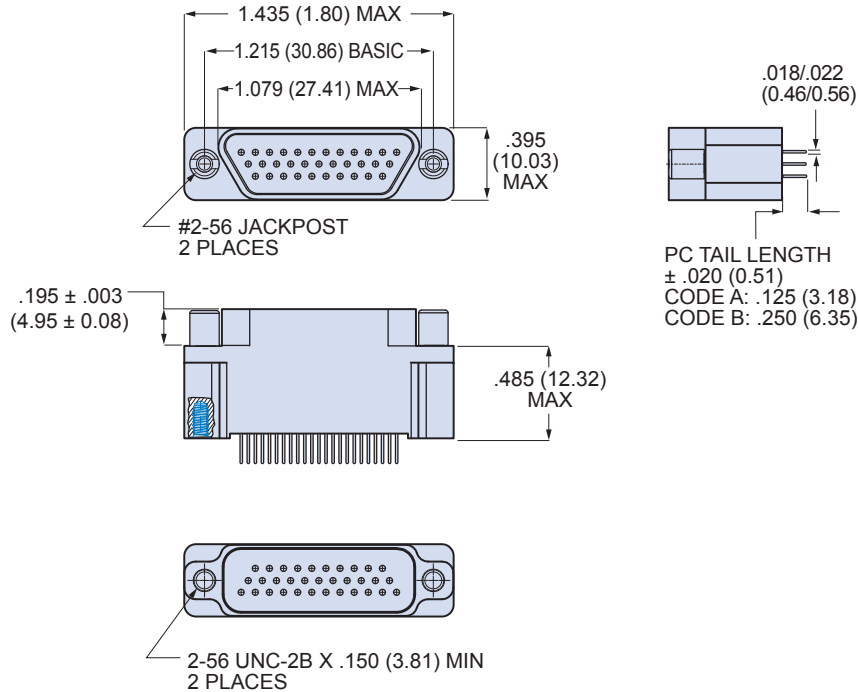

Dimensions in Inches (millimeters) are subject to change without notice.

790-043P
Straight PCB Terminated
Free-Standing Receptacle, Pin Contacts
Dimensions



790-043P Shell Size H and L Dimensions

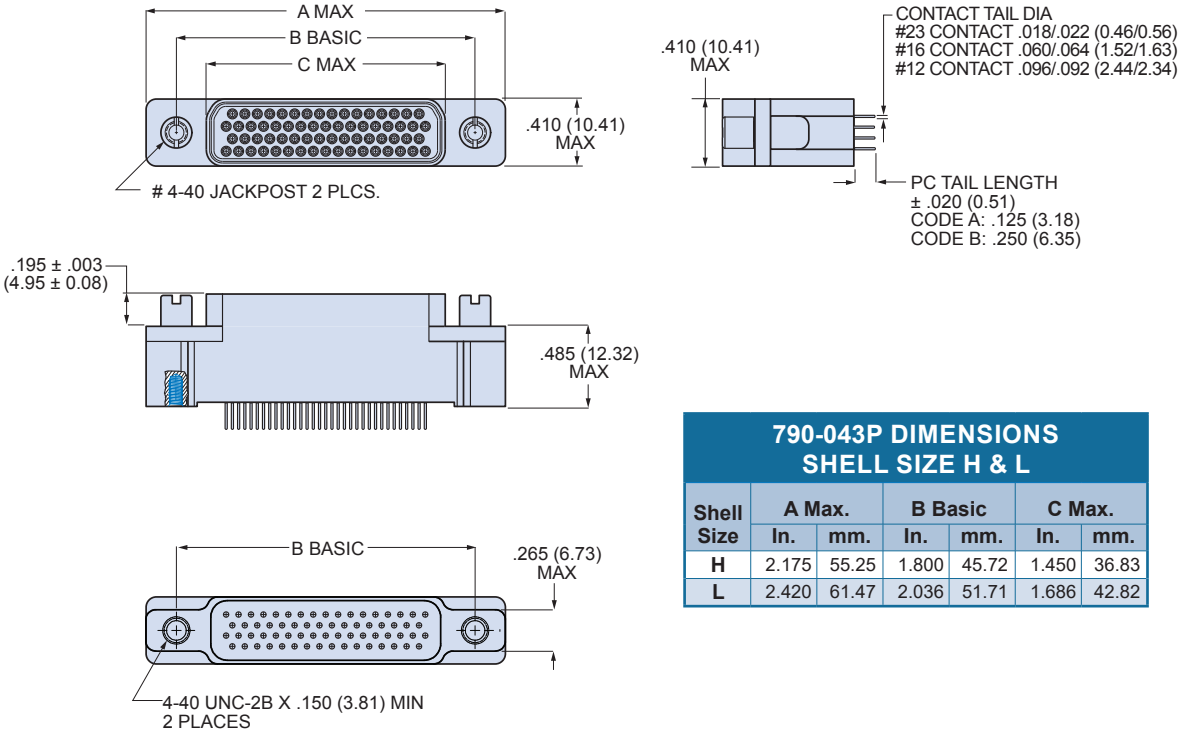

790-043P Shell Size M Dimensions

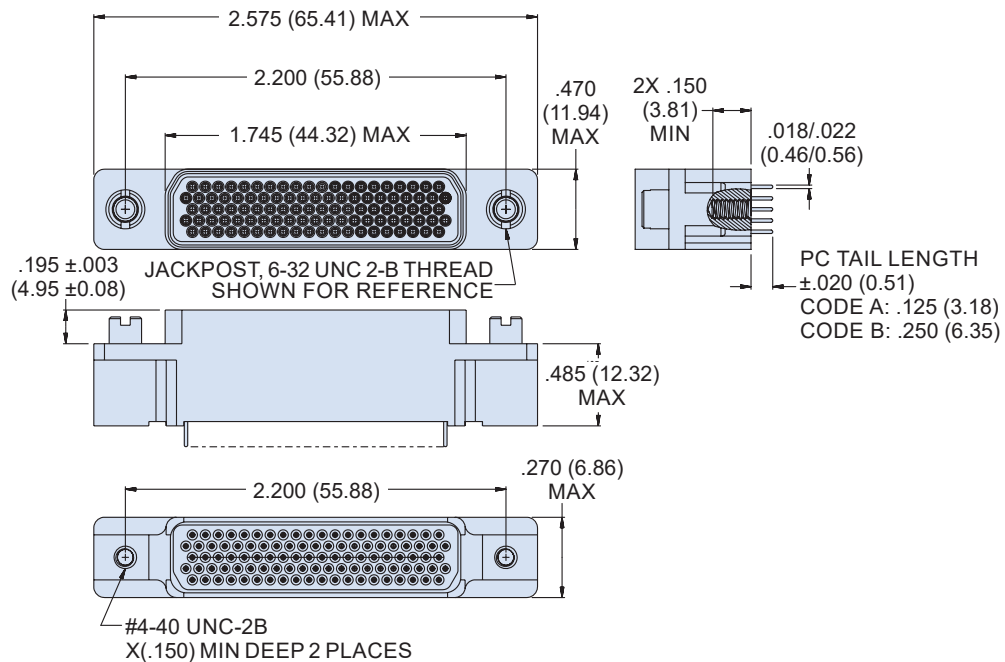

Dimensions in Inches (millimeters) are subject to change without notice.



790-028P and 790-043P Straight PCB Connectors Receptacle PCB Hole Patterns

790-028P and 790-043P Receptacle PCB Hole Patterns

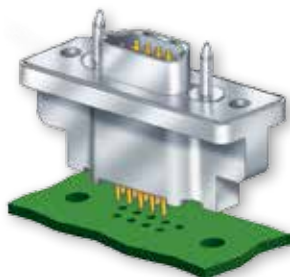

This section contains printed circuit board footprints for vertical mounted Series 79 receptacles. The contact identification numbers are shown for the connector mounting side of the PCB. Contact tails are gold over nickel plated.

Contact Size	PC Tail Diameter	
	Ø Diameter In.	Ø Diameter mm.
#23	.018-.022	0.46-0.56
#16	.060-.064	1.52-1.63
#12	.092-.096	2.34-2.44

790-028P AND 790-043P PRINTED CIRCUIT BOARD PATTERNS

Insert Arrangement

Component Mounting Side of PCB

A-5

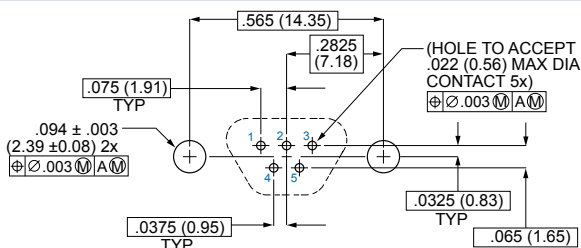

B-2P2

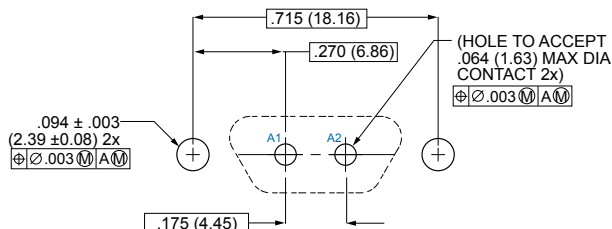

B-9

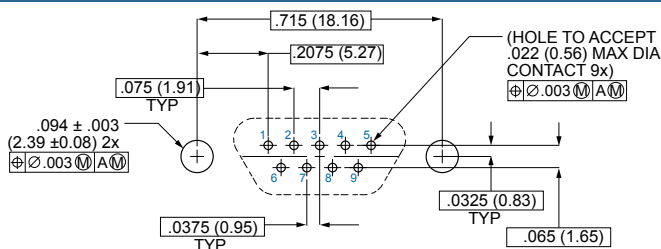

C-13

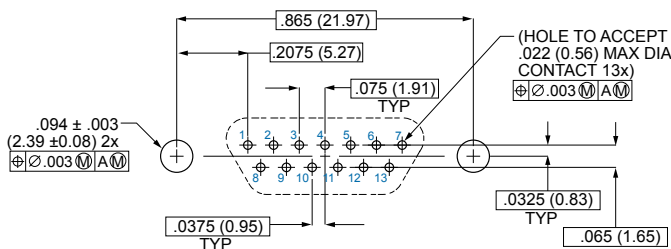

Dimensions in Inches (millimeters) are subject to change without notice.

790-028P and 790-043P Straight PCB Connectors Receptacle PCB Hole Patterns



790-028P AND 790-043P PRINTED CIRCUIT BOARD PATTERNS

Insert Arrangement	Component Mounting Side of PCB
D-15	
D-3P3	
D-7P2	
E-11P2	
E-19	

Dimensions in Inches (millimeters) are subject to change without notice.



790-028P AND 790-043P PRINTED CIRCUIT BOARD PATTERNS

Insert Arrangement	Component Mounting Side of PCB
E-7P3	
F-15P2	
F-23	
F-5P5	
G-33	

Dimensions in Inches (millimeters) are subject to change without notice.

790-028P and 790-043P Straight PCB Connectors Receptacle PCB Hole Patterns



790-028P AND 790-043P PRINTED CIRCUIT BOARD PATTERNS

Insert Arrangement	Component Mounting Side of PCB
H-10P4	
H-29P7	
H-36P2	
H-54P2	
H-5P5	

Dimensions in Inches (millimeters) are subject to change without notice.



790-028P AND 790-043P PRINTED CIRCUIT BOARD PATTERNS

Insert Arrangement	Component Mounting Side of PCB
H-66	
J-17P4	
J-25P2	
J-33	
J-7P7	
K-27P4	

Dimensions in Inches (millimeters) are subject to change without notice.

790-028P and 790-043P Straight PCB Connectors Receptacle PCB Hole Patterns



790-028P AND 790-043P PRINTED CIRCUIT BOARD PATTERNS

Insert Arrangement	Component Mounting Side of PCB
K-35P2	
K-43	
K-9P9	
L-6P6	
L-78	
M-102	

Dimensions in Inches (millimeters) are subject to change without notice.





790-029S
Straight PCB Terminated
Panel Mount Plugs, Socket Contacts
How To Order

790-029S Straight PCB Panel Mount Plugs

SOCKET CONTACTS WITH STRAIGHT PCB TERMINATION



Lightweight, rugged vertical mount headers feature gold-plated PC tail contacts for thru-hole printed circuit board termination. 790-029S connectors are designed for rear-panel mounting and are supplied with conductive panel gaskets. Contacts are permanently installed and are sealed with epoxy. Shells are aluminum alloy. Threaded board mounting holes and integral standoffs simplify installation. Available in 29 different contact arrangements, these connectors feature size #23 signal contacts along with #16 and #12 power contacts for up to 23 amps current rating. Optional EMI spring improves shell-to-shell conductivity and shielding performance. Stainless steel jackposts are non-removable.

HOW TO ORDER

Sample Part Number

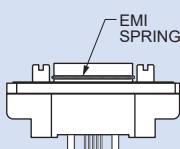
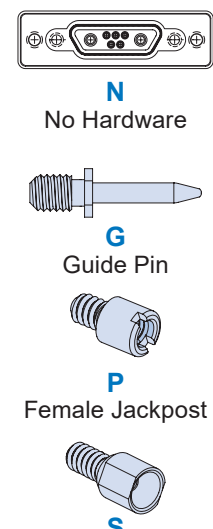
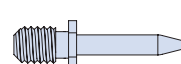
790-029S	K-43	M	E	P	B
Part Number	Shell Size - Insert Arrangements	Shell Finish	EMI Spring	Hardware Option	PC Tail Length
790-029S Rear Panel Mounted Plug with Straight PC Tail Contacts for Termination to Backplanes or Flexible Circuits	See Table 1 for Available Insert Arrangements	M Electroless Nickel <i>general purpose applications</i> MT Nickel-PTFE <i>1000 Hour Grey™ maximum corrosion protection and durability (non-reflective grey)</i> ZNU Zinc-Nickel with Black Chromate <i>tactical applications (non-reflective black)</i> Additional shell finishes are listed on page C-9.	E EMI Spring N No Spring  Note: EMI Spring is not compatible with chromate finishes including cadmium and zinc-nickel	 N No Hardware G Guide Pin P Female Jackpost S Female Guide Socket	A .125 Inch (3.2 mm.) B .250 inch (6.4 mm.)  PC TAIL LENGTH

SPECIFICATIONS

Current Rating	#23 5 AMPS, #16 13 A., #12 23 A.
Dielectric Withstanding Voltage	#23 500 VAC RMS, #12 and #16 1800 VAC RMS
Insulation Resistance	5000 megohms minimum
Operating Temperature	-65° C. to +150° C.
Shock	300 g.
Vibration	37 g.

MATERIALS AND FINISHES

Shell	Aluminum alloy
Contacts	Copper alloy, 50 microinches gold plated, with stainless steel hoods
Insulator	Liquid crystal polymer (LCP)
Hardware	300 series stainless steel
Panel Gasket	Fluorosilicone, conductive
Encapsulant	Epoxy

Dimensions in Inches (millimeters) are subject to change without notice.

790-029S
Straight PCB Terminated
Panel Mount Plugs, Socket Contacts
How To Order



Table Contact Arrangements

Layout	Contact Quantity			Face View
	#23	#16	#12	
A-5	5			
B-2P2		2		
B-9	9			
C-13	13			
D-15	15			
D-3P3		3		
D-7P2	5	2		
E-11P2	9	2		
E-19	19			
E-7P3	4	3		
F-15P2	13	2		
F-23	23			
F-5P5		5		
G-33	33			
H-10P4	6	4		
H-29P7	22	7		
H-36P2	34	2		
H-54P2	52	2		
H-5P5		5		
H-66	66			
J-17P4	13	4		
J-25P2	23	2		
J-33	33			
J-7P7		7		
K-27P4	23	4		
K-35P2	33	2		
K-43	43			
K-9P9		9		
L-6P6		6		
L-78	78			
M-102	102			

CROSS-SECTIONAL VIEW OF 790-029S

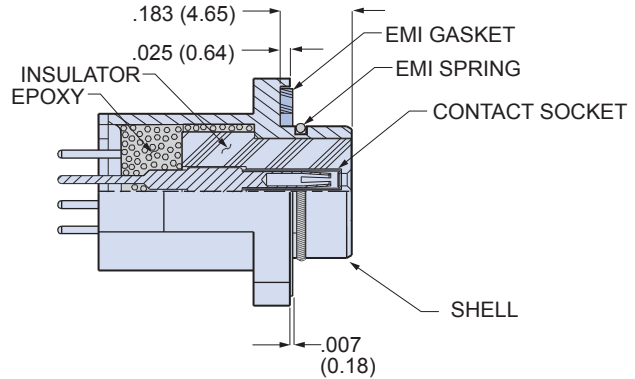
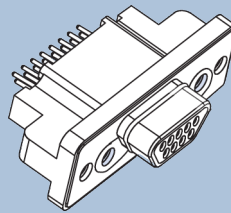

TABLE 2 HARDWARE OPTION



N

No Mating Hardware

Connector is supplied with threaded holes. Shell size M has #8-32 threads, shell sizes H and L have #6-32 threads, other sizes have #4-40 threads. Thread depth is .150" (3.8).

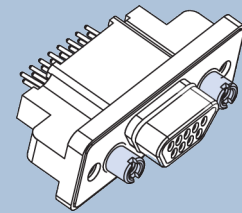

P

Jackposts

Connector is supplied with non-removable stainless steel jackposts. Shell size M has #6-32 threads, shell sizes H and L have #4-40 UNC thread, other sizes have #2-56 thread.

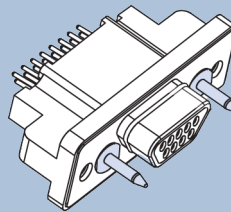

G

Guide Pins

Connector is supplied with stainless steel non-removable guide pins. Mates with type "S" guide sockets on corresponding receptacle connector.

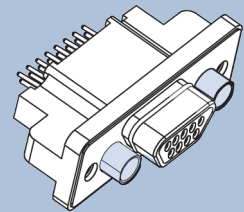

S

Guide Sockets

Connector is supplied with stainless steel non-removable bushings. Mates with type "G" guide pins on corresponding receptacle connector.

Dimensions in Inches (millimeters) are subject to change without notice.

790-029S Shell Size A, B, C, D, E, F, J and K Dimensions

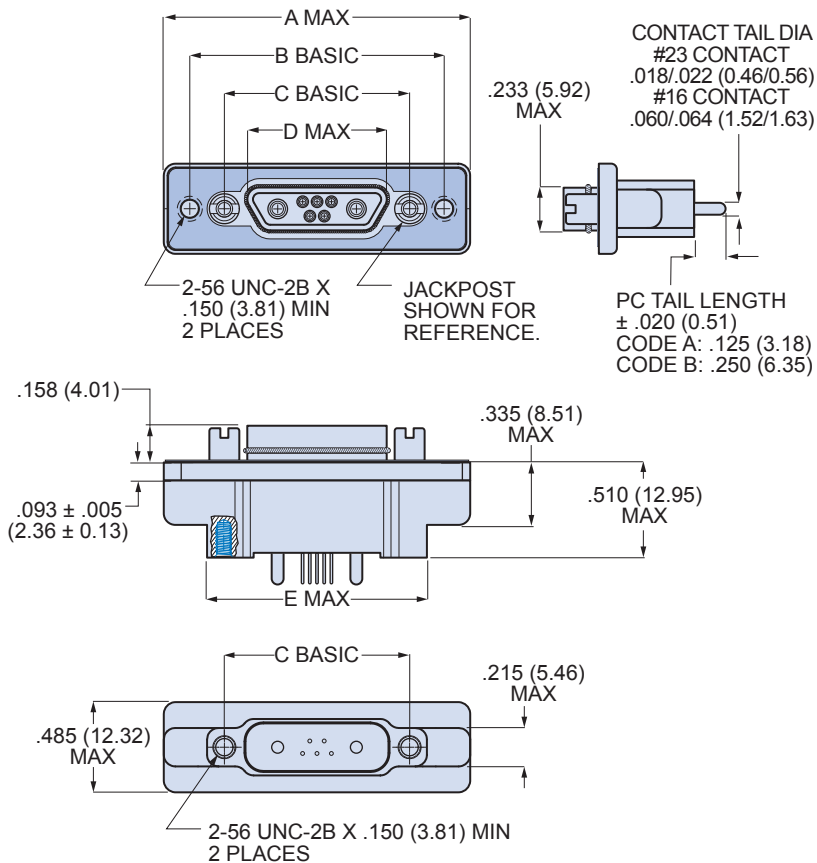

BLIND MATE

SHELL SIZES A, B, C, D, E, F, G, J, K
+/- .030 (0.76) ALLOWABLE
MISALIGNMENT FROM CENTERLINE

F

790-029S SIZE A-F, J, K DIMENSIONS										
Shell Size	A Max.		B Basic		C Basic		D Max.		E Max.	
	In.	mm.	In.	mm.	In.	mm.	In.	mm.	In.	mm.
A	1.211	30.76	.925	23.50	.565	14.35	.335	8.51	.760	19.30
B	1.361	34.57	1.075	27.31	.715	18.16	.485	12.32	.910	21.11
C	1.511	38.38	1.225	31.12	.865	21.97	.635	16.13	1.060	26.92
D	1.611	40.92	1.325	33.66	.965	24.51	.735	18.67	1.160	29.46
E	1.761	44.73	1.475	37.47	1.115	28.32	.885	22.48	1.310	33.27
F	1.911	48.54	1.625	41.28	1.265	32.13	1.035	26.29	1.460	37.08
J	2.261	57.43	1.975	50.17	1.615	41.02	1.390	35.31	1.810	45.97
K	2.661	67.59	2.375	60.33	2.015	51.18	1.795	45.59	2.210	56.13

Dimensions in Inches (millimeters) are subject to change without notice.

790-029S
Straight PCB Terminated
Panel Mount Plugs, Socket Contacts
Dimensions



790-029S Shell Size G Dimensions

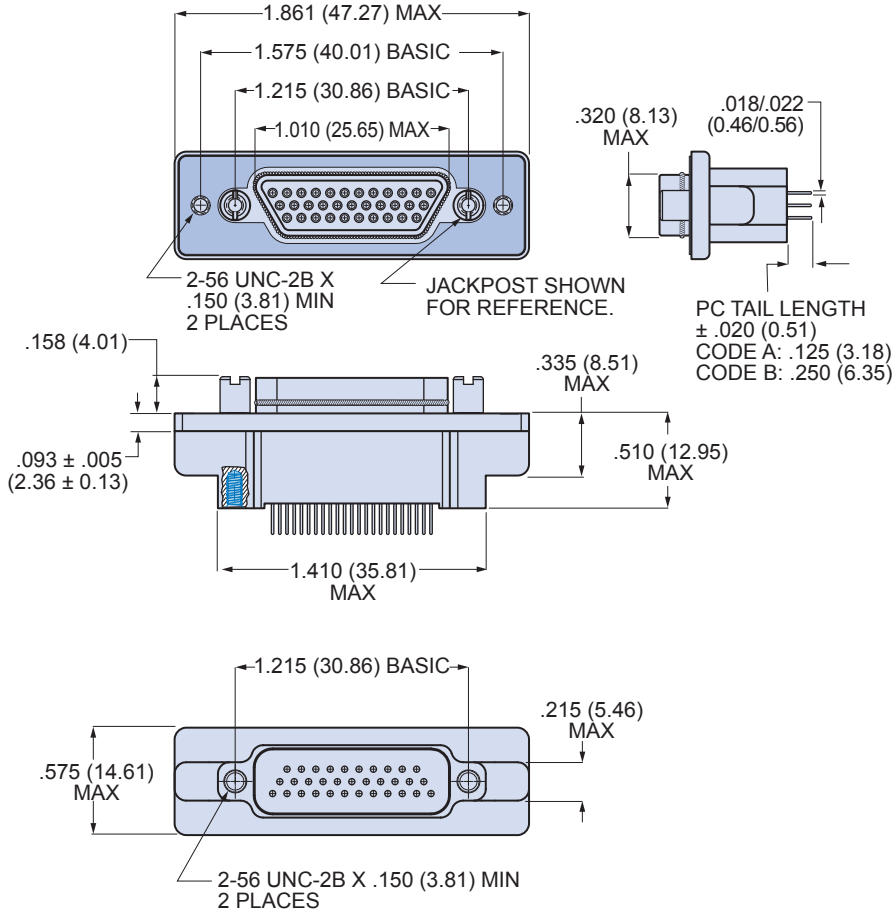

BLIND MATE

SHELL SIZES A, B, C, D, E, F, G, J, K
 +/- .030 (0.76) ALLOWABLE
 MISALIGNMENT FROM CENTERLINE



Dimensions in Inches (millimeters) are subject to change without notice.

790-029S Shell Size H & L Dimensions

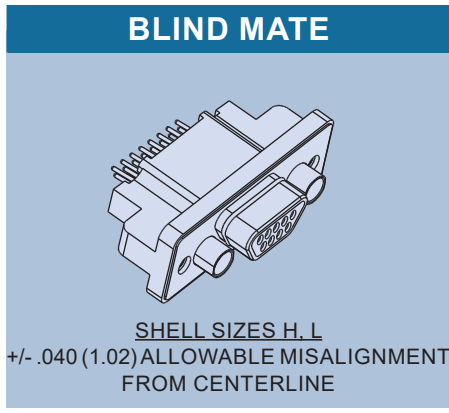
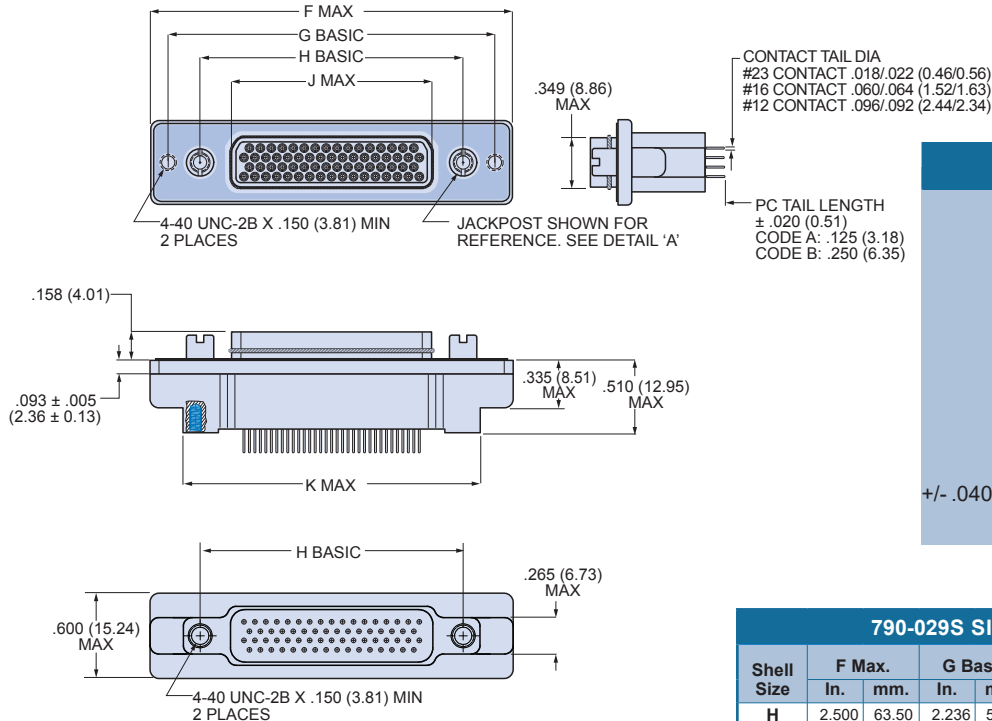

790-029S SIZE H & L DIMENSIONS										
Shell Size	F Max.		G Basic		H Basic		J Max.		K Max.	
	In.	mm.	In.	mm.	In.	mm.	In.	mm.	In.	mm.
H	2.500	63.50	2.236	56.79	1.800	45.72	1.385	35.18	2.045	51.94
L	2.736	69.49	2.472	62.79	2.036	51.71	1.623	41.22	2.281	57.94

790-029S Shell Size M Dimensions

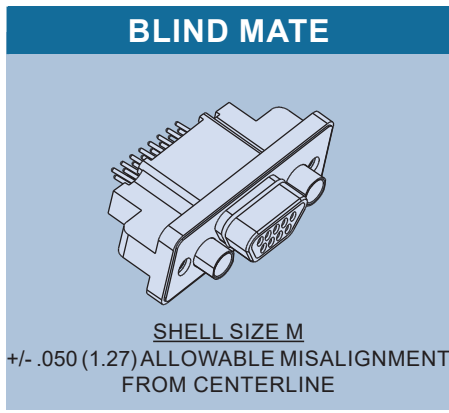
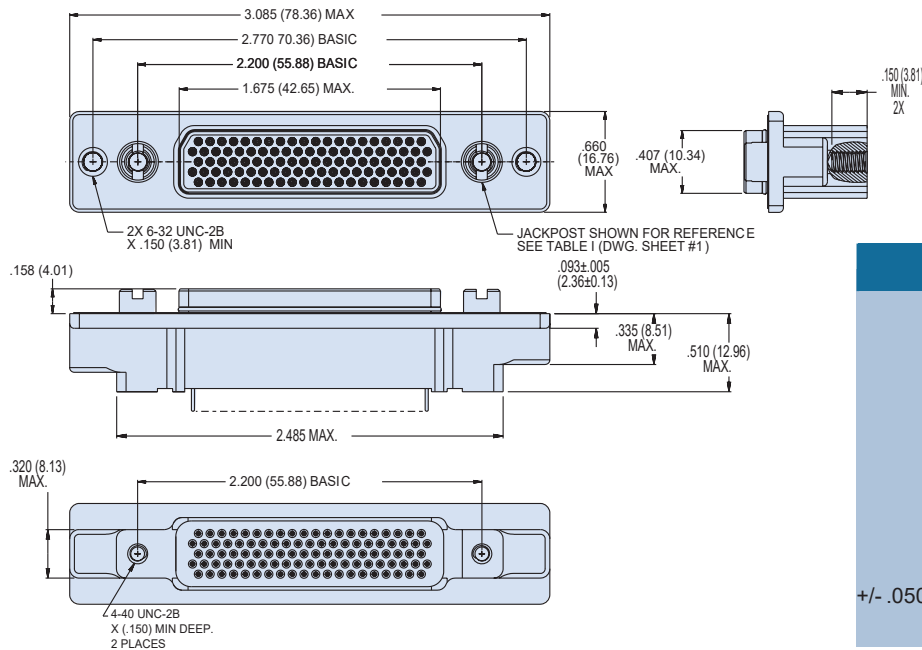

Dimensions in Inches (millimeters) are subject to change without notice.

790-044S Straight PCB Free-Standing Plugs

SOCKET CONTACTS WITH STRAIGHT PCB TERMINATION

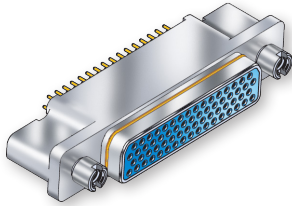

Free-standing, rugged vertical mount headers feature gold-plated PC tail contacts for thru-hole printed circuit board termination. Contacts are permanently installed and are sealed with epoxy. Shells are aluminum alloy. Threaded board mounting holes and integral standoffs simplify installation. Available in 29 different contact arrangements, these connectors feature size #23 signal contacts along with #16 and #12 power contacts for up to 23 amps current rating. Optional EMI spring improves shell-to-shell conductivity and shielding performance. Stainless steel jackposts are non-removable.

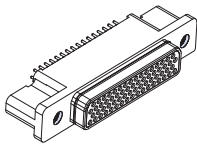
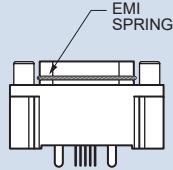
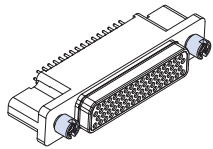
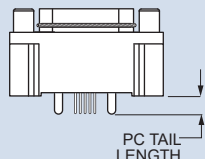
HOW TO ORDER					
Sample Part Number					
790-044S	D-15	MT	E	P	B
Part Number	Shell Size - Insert Arrangements	Shell Finish	EMI Spring	Hardware Option	PC Tail Length
790-044S Plug with Straight Thru-Hole PC Tail Contacts for Termination to Backplanes or Flexible Circuits	See Table 1 for Available Insert Arrangements	M Electroless Nickel <i>general purpose applications</i>	E EMI Spring	 N No Hardware	A .125 Inch (3.2 mm.)
		MT Nickel-PTFE 1000 Hour Grey™ <i>maximum corrosion protection and durability (non-reflective grey)</i>	N No Spring		B .250 inch (6.4 mm.)
		ZNU Zinc-Nickel with Black Chromate <i>tactical applications (non-reflective black)</i> Additional shell finishes are listed on page C-9.	 Note: EMI Spring is not compatible with chromate finishes including cadmium and zinc-nickel	 P Female Jackpost	 PC TAIL LENGTH

SPECIFICATIONS	
Current Rating	#23 5 AMPS, #16 13 A., #12 23 A.
Dielectric Withstanding Voltage	#23 500 VAC RMS, #12 and #16 1800 VAC RMS
Insulation Resistance	5000 megohms minimum
Operating Temperature	-65° C. to +150° C.
Shock	300 g.
Vibration	37 g.

MATERIALS AND FINISHES	
Shell	Aluminum alloy
Contacts	Copper alloy, 50 microinches gold plated, stainless steel hood
Insulator	Liquid crystal polymer (LCP)
Jackposts	300 series stainless steel
Encapsulant	Epoxy

Dimensions in Inches (millimeters) are subject to change without notice.



790-044S Straight PCB Terminated Free Standing Plugs, Socket Contacts How To Order

Table 1 Contact Arrangements

Layout	Contact Quantity			Face View
	#23	#16	#12	
A-5	5			
B-2P2	2			
B-9	9			
C-13	13			
D-15	15			
D-3P3	3			
D-7P2	5	2		
E-11P2	9	2		
E-19	19			
E-7P3	4	3		
F-15P2	13	2		
F-23	23			
F-5P5	5			
G-33	33			
H-10P4	6	4		
H-29P7	22	7		
H-36P2	34	2		
H-54P2	52	2		
H-5P5		5		
H-66	66			
J-17P4	13	4		
J-25P2	23	2		
J-33	33			
J-7P7	7			
K-27P4	23	4		
K-35P2	33	2		
K-43	43			
K-9P9	9			
L-6P6		6		
L-78	78			
M-102	102			

CROSS-SECTIONAL VIEW OF 790-044S

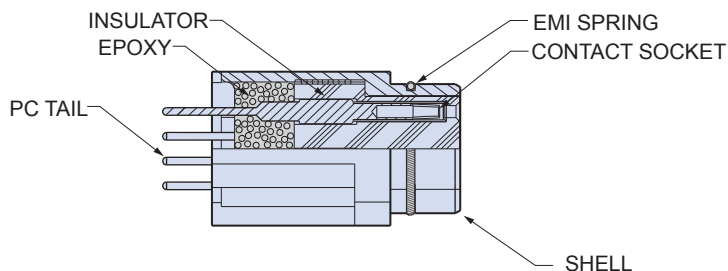
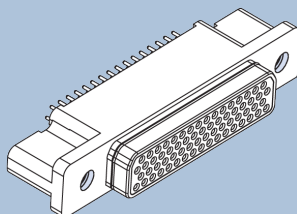

TABLE 2 HARDWARE OPTION



N

No Mating Hardware

Connector is supplied with threaded holes. Shell size M has #8-32 threads, shell sizes H and L have #6-32 threads, other sizes have #4-40 threads. Thread depth is .150" (3.8).

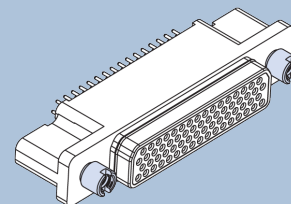

P

Jackposts

Connector is supplied with non-removable stainless steel jackposts. Shell size M has #6-32 threads, shell sizes H and L have #4-40 UNC thread, other sizes have #2-56 thread.

Dimensions in Inches (millimeters) are subject to change without notice.

790-044S
Straight PCB Terminated
Free Standing Plugs, Socket Contacts
Dimensions



790-044S Shell Size A, B, C, D, E, F, J and K Dimensions

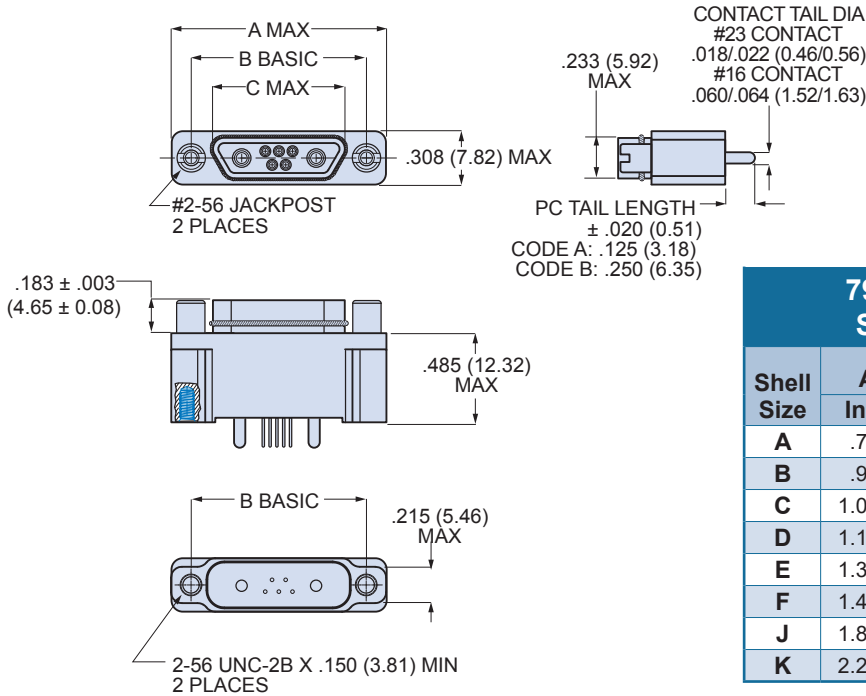

790-044S DIMENSIONS SHELL SIZE A-G, J, K						
Shell Size	A Max.		B Basic		C Max.	
	In.	mm.	In.	mm.	In.	mm.
A	.785	19.94	.565	14.35	.335	8.51
B	.935	23.75	.715	18.16	.485	12.32
C	1.085	27.56	.865	21.97	.635	16.13
D	1.185	30.10	.965	24.51	.735	18.67
E	1.335	33.91	1.115	28.32	.885	22.48
F	1.485	37.72	1.265	32.13	1.035	26.29
J	1.845	46.86	1.615	41.02	1.390	35.61
K	2.240	56.90	2.015	51.18	1.795	45.59

790-044S Shell Size G Dimensions

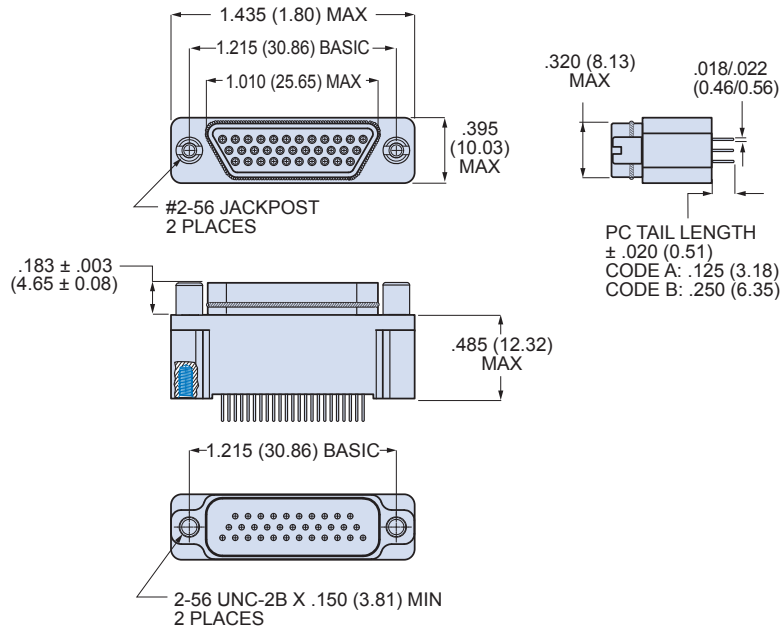

Dimensions in Inches (millimeters) are subject to change without notice.

790-044S Shell Size H & L Dimensions

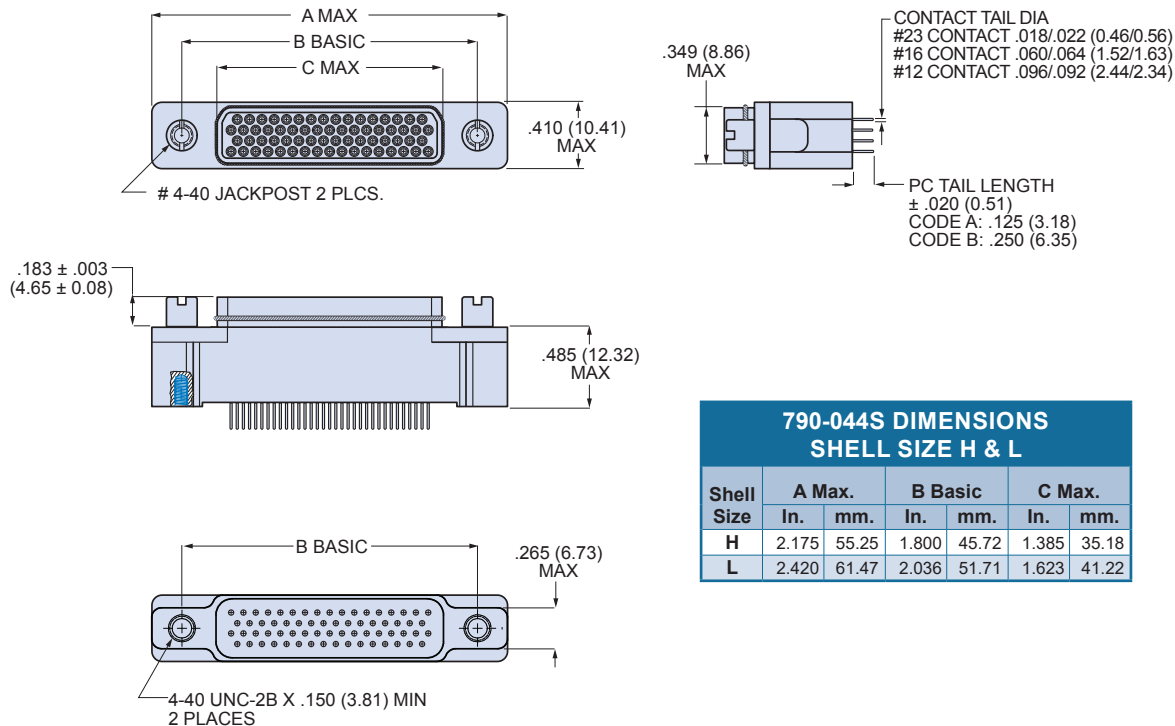

790-044S Shell Size M Dimensions

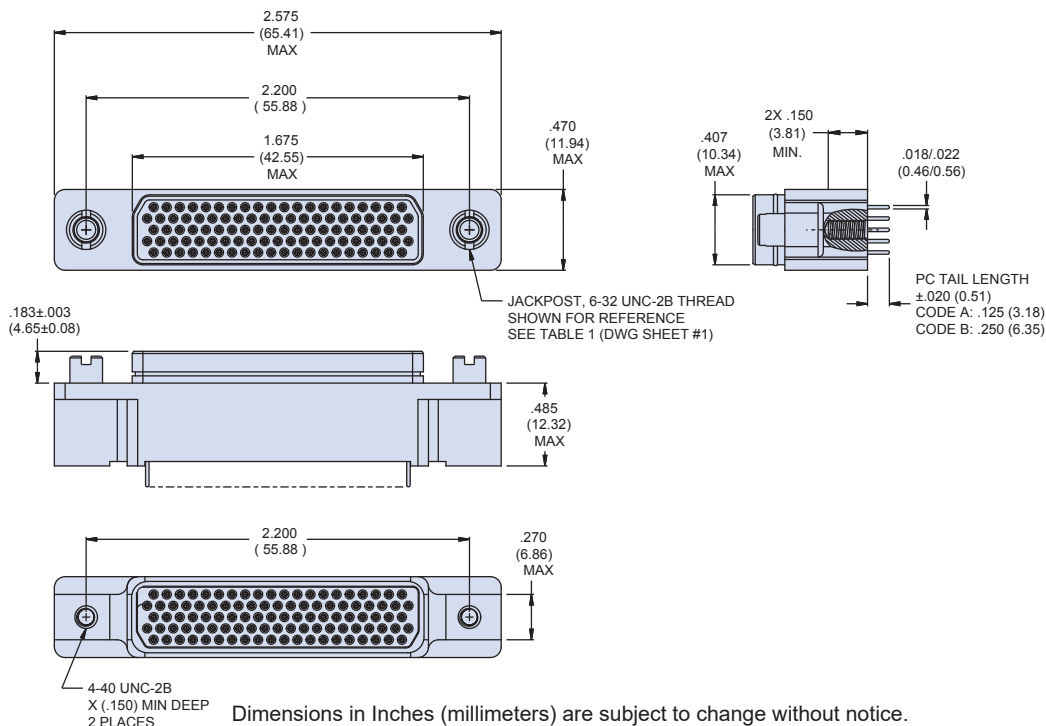

Dimensions in Inches (millimeters) are subject to change without notice.

790-029S and 790-044S Plugs PCB Hole Patterns

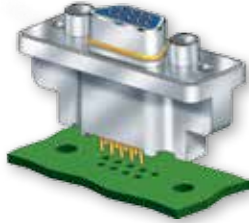

This section contains printed circuit board footprints for vertical mounted Series 79 plugs. The contact identification numbers are shown for the connector mounting side of the PC board. Contact tails are gold over nickel plated.

Contact Size	PC Tail Diameter	
	Ø Diameter In.	Ø Diameter mm.
#23	.018-.022	0.46-0.56
#16	.060-.064	1.52-1.63
#12	.092-.096	2.34-2.44

790-029S AND 790-044S PRINTED CIRCUIT BOARD PATTERNS

Insert Arr.	Component Mounting Side of PCB
A-5	
B-2P2	
B-9	
C-13	

Dimensions in Inches (millimeters) are subject to change without notice.

790-029S AND 790-044S PRINTED CIRCUIT BOARD PATTERNS

Insert Arr.	Component Mounting Side of PCB
D-15	
D-3P3	
D-7P2	
E-11P2	
E-19	

Dimensions in Inches (millimeters) are subject to change without notice.

790-029S and 790-044S Straight PCB Connectors Plug PCB Hole Patterns



790-029S AND 790-044S PRINTED CIRCUIT BOARD PATTERNS

Insert Arr.	Component Mounting Side of PCB
E-7P3	
F-15P2	
F-23	
F-5P5	
G-33	

Dimensions in Inches (millimeters) are subject to change without notice.



790-029S AND 790-044S PRINTED CIRCUIT BOARD PATTERNS

Insert Arr.	Component Mounting Side of PCB
H-10P4	
H-29P7	
H-36P2	
H-54P2	
H-5P5	

Dimensions in Inches (millimeters) are subject to change without notice.

790-029S and 790-044S Straight PCB Connectors Plug PCB Hole Patterns



790-029S AND 790-044S PRINTED CIRCUIT BOARD PATTERNS

Insert Arr.	Component Mounting Side of PCB
H-66	<p>Dimensions: $.300 (7.62)$, $1.800 (45.72)$, $.0375 (0.95)$ TYP, $.125 \pm .003 (3.18 \pm 0.08) 2x$, $\phi .0325 (0.83)$ TYP, $.065 (1.65)$ TYP, $.075 (1.91)$ TYP, $\phi .022 (0.56)$ MAX DIA CONTACT 88x, $\phi .0325 (0.83)$ TYP, $\phi .003 (A)$</p>
J-17P4	<p>Dimensions: $.2575 (6.54)$, $.150 (3.81)$, $1.615 (41.02)$, $.094 \pm .003 (2.39 \pm 0.08) 2x$, $\phi .0325 (0.83)$ TYP, $.065 (1.65)$ TYP, $.075 (1.91)$ TYP, $\phi .022 (0.56)$ MAX DIA CONTACT 13x, $\phi .0325 (0.83)$ TYP, $\phi .003 (A)$, $\phi .064 (1.63)$ MAX DIA CONTACT 4x, $\phi .0375 (0.95)$ TYP, $.175 (4.45)$, $1.100 (27.94)$</p>
J-25P2	<p>Dimensions: $.2575 (6.54)$, $.395 (10.03)$, $1.615 (41.02)$, $.094 \pm .003 (2.39 \pm 0.08) 2x$, $\phi .0325 (0.83)$ TYP, $.065 (1.65)$ TYP, $.075 (1.91)$ TYP, $\phi .022 (0.56)$ MAX DIA CONTACT 23x, $\phi .0325 (0.83)$ TYP, $\phi .003 (A)$, $\phi .064 (1.63)$ MAX DIA CONTACT 2x, $\phi .0375 (0.95)$ TYP, $1.100 (27.94)$</p>
J-33	<p>Dimensions: $.2075 (5.27)$, $.075 (1.91)$ TYP, $1.615 (41.02)$, $.094 \pm .003 (2.39 \pm 0.08) 2x$, $\phi .0325 (0.83)$ TYP, $.065 (1.65)$ TYP, $\phi .022 (0.56)$ MAX DIA CONTACT 33x, $\phi .0325 (0.83)$ TYP, $\phi .003 (A)$, $\phi .0375 (0.95)$ TYP</p>
J-7P7	<p>Dimensions: $.2825 (7.18)$, $.075 (1.91)$ TYP, $1.615 (41.02)$, $.094 \pm .003 (2.39 \pm 0.08) 2x$, $\phi .0325 (0.83)$ TYP, $\phi .064 (1.63)$ MAX DIA CONTACT 2x, $\phi .0375 (0.95)$ TYP, $.175 (4.45)$ 6x, $\phi .003 (A)$</p>
K-27P4	<p>Dimensions: $.595 (15.11)$, $.4325 (10.99)$, $.2575 (6.54)$, $2.015 (51.18)$, $.0375 (0.95)$ TYP, $.075 (1.91)$ TYP, $.094 \pm .003 (2.39 \pm 0.08) 2x$, $\phi .0325 (0.83)$ TYP, $.065 (1.65)$ TYP, $\phi .022 (0.56)$ MAX DIA CONTACT 23x, $\phi .0325 (0.83)$ TYP, $\phi .003 (A)$, $\phi .064 (1.63)$ MAX DIA CONTACT 4x, $\phi .0375 (0.95)$ TYP, $1.150 (29.21)$, $1.500 (38.1)$</p>

Dimensions in Inches (millimeters) are subject to change without notice.

790-029S AND 790-044S PRINTED CIRCUIT BOARD PATTERNS

Insert Arr.	Component Mounting Side of PCB
K-35P2	<p>Dimensions: 2.015 (51.18), 1.500 (38.1), 2.575 (6.54), 4.075 (10.35), .094 ± .003 (2.39 ± 0.08) 2x, .075 (1.91) TYP, .0325 (0.83) TYP, .065 (1.65) TYP, .3075 (7.81) TYP, .175 (4.45), .0375 (0.95) TYP, .022 (0.56) MAX DIA CONTACT 33x, .064 (1.63) MAX DIA CONTACT 2x, .022 (0.56) MAX DIA CONTACT 43x, .096 (2.44) MAX DIA CONTACT 6x, .023 CONTACT 78x, .023 CONTACT 102x.</p>
K-43	<p>Dimensions: 2.015 (51.18), .220 (5.59), .094 ± .003 (2.39 ± 0.08) 2x, .075 (1.91) TYP, .0375 (0.95) TYP, .0325 (0.83) TYP, .065 (1.65) TYP, .022 (0.56) MAX DIA CONTACT 43x.</p>
K-9P9	<p>Dimensions: 2.015 (51.18), .3075 (7.81), .175 (4.45), .094 ± .003 (2.39 ± 0.08) 2x, .064 (1.63) MAX DIA CONTACT 9.</p>
L-6P6	<p>Dimensions: 2.036 (51.71), .428 (10.87), .125 ± .003 (3.18 ± 0.08) 2x, .236 (5.99) 5x, .096 (2.44) MAX DIA CONTACT 6x.</p>
L-78	<p>Dimensions: 2.036 (51.71), .3055 (7.76), .075 (1.91) TYP, .038 (.97) TYP, .125 ± .003 (3.18 ± 0.08) 2x, .0325 (.83) TYP, .065 (1.65) TYP, .023 CONTACT 78x.</p>
M-102	<p>Dimensions: 2.200 (55.88), .350 (8.89), .075 (1.91) TYP, .038 (.97) TYP, .125 ± .003 (3.18 ± 0.08) 2x, .065 (1.65) TYP, .0325 (.83) TYP, .023 CONTACT 102x.</p>

Dimensions in Inches (millimeters) are subject to change without notice.

790-036P
Right Angle PCB Terminated
Panel Mount Receptacle, Pin Contacts
How To Order



790-036P Right Angle PCB Panel Mount Receptacles
PIN CONTACTS WITH RIGHT ANGLE PCB TERMINATION

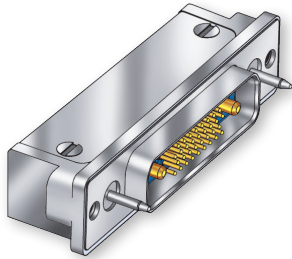

Lightweight, rugged right angle headers feature gold-plated contacts for thru-hole printed circuit board termination. 790-036P connectors are designed for rear-panel mounting and are supplied with conductive panel gaskets. Contacts are permanently installed and are sealed with epoxy. Shells are aluminum alloy. Threaded board mounting holes and integral standoffs simplify installation. EMI shroud improves EMI performance. Fluorosilicone face seal provides watertight interface. Available in 29 different contact arrangements, these connectors feature size #23 signal contacts along with #16 and #12 power contacts for up to 23 amps current rating.

HOW TO ORDER

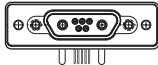
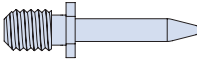
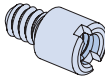
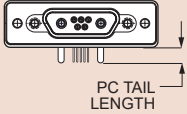
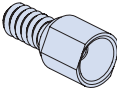
Sample Part Number				
790-036P	D-7P2	MT	P	A
Part Number	Shell Size - Insert Arrangements	Shell Finish	Hardware Option	PC Tail Length
790-036P Rear-Panel Mounted Receptacle with 90° PC Tail Pin Contacts for Termination to Backplanes or Flexible Circuits	See Table 1 for Available Insert Arrangements	M Electroless Nickel <i>general purpose applications</i>	 N No Hardware	A .125 Inch (3.2 mm.)
		MT Nickel-PTFE 1000 Hour Grey™ <i>maximum corrosion protection and durability (non-reflective grey)</i>	 G Guide Pin	B .250 inch (6.4 mm.)
		ZNU Zinc-Nickel with Black Chromate <i>tactical applications (non-reflective black)</i>	 P Female Jackpost	 PC TAIL LENGTH
		Additional shell finishes are listed on page C-9.	 S Female Guide Socket	

SPECIFICATIONS

Current Rating	#23 5 AMPS, #16 13 A., #12 23 A.
Dielectric Withstanding Voltage	#23 500 VAC RMS, #12 and #16 1800 VAC RMS
Insulation Resistance	5000 megohms minimum
Operating Temperature	-65° C. to +150° C.
Shock	300 g.
Vibration	37 g.

MATERIALS AND FINISHES

Shell	Aluminum alloy
Contacts	Copper alloy, 50 microinches gold plated
Insulator	Liquid crystal polymer (LCP)
Interfacial Seal	Fluorosilicone rubber
Hardware	300 series stainless steel
Panel Gasket	Fluorosilicone, conductive
Encapsulant	Epoxy

Dimensions in Inches (millimeters) are subject to change without notice.



790-036P Right Angle PCB Terminated Panel Mount Receptacle, Pin Contacts How To Order

Table Contact Arrangements

Layout	Contact Quantity			Face View
	#23	#16	#12	
A-5	5			
B-2P2		2		
B-9	9			
C-13	13			
D-15	15			
D-3P3		3		
D-7P2	5	2		
E-11P2	9	2		
E-19	19			
E-7P3	4	3		
F-15P2	13	2		
F-23	23			
F-5P5		5		
G-33	33			
H-10P4	6	4		
H-29P7	22	7		
H-36P2	34	2		
H-54P2	52	2		
H-5P5		5		
H-66	66			
J-17P4	13	4		
J-25P2	23	2		
J-33	33			
J-7P7	7			
K-27P4	23	4		
K-35P2	33	2		
K-43	43			
K-9P9	9			
L-6P6		6		
L-78	78			
M-102	102			

CROSS-SECTIONAL VIEW OF 790-036P

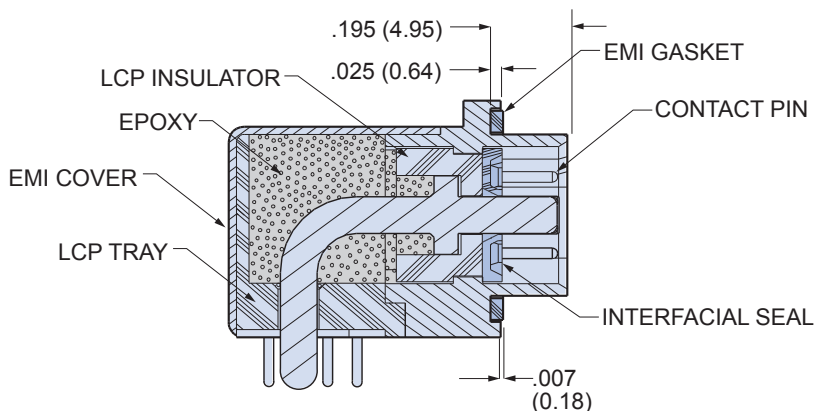
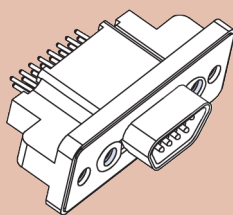

TABLE 2: HARDWARE OPTION



N

No Mating Hardware

Connector is supplied with blind, tapped holes. Shell size M have 8-32 UNC-2B thread, shell sizes H and L have 6-32 UNC-2B thread, other sizes are #4-40. Minimum thread depth is .150" (3.81).

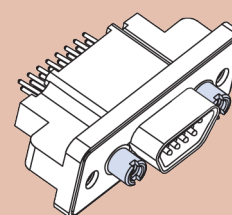

P

Jackposts

Connector is supplied with non-removable jackposts. Shell size M have 6-32 UNC-2B thread, shell sizes H and L have #4-40 UNC-2B thread, other sizes have #2-56 thread.

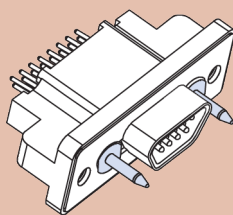

G

Male Guide Pins

Connector is supplied with stainless steel guide pins to mate with code S guide sockets. Pins are non-removable.

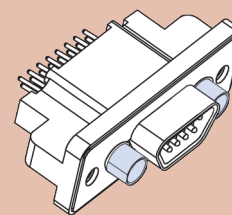

S

Female Guide Sockets

Connector is supplied with stainless steel guide sockets to mate with code G guide pins. Sockets are non-removable.

Dimensions in Inches (millimeters) are subject to change without notice.

790-036P
Right Angle PCB Terminated
Panel Mount Receptacle, Pin Contacts
Dimensions



Series79
 90° PCB
 Connectors

790-036P Shell Sizes A-F, J and K Dimensions

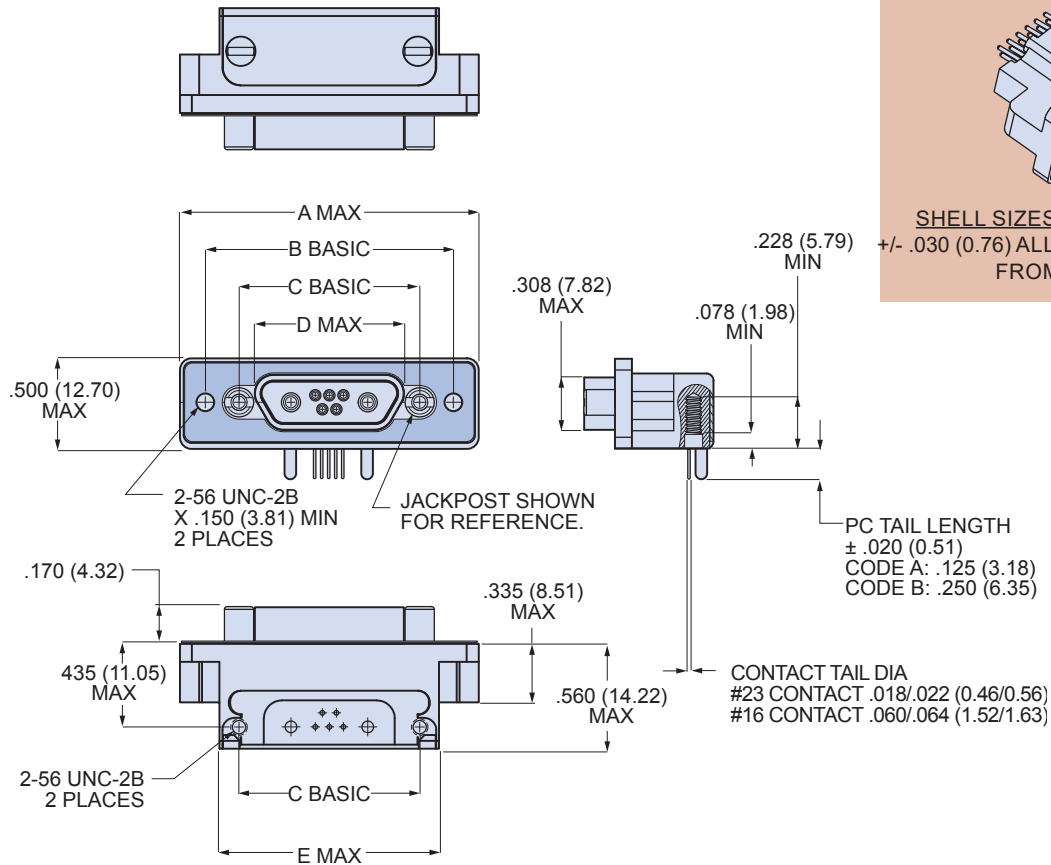

BLIND MATE

SHELL SIZES A, B, C, D, E, F, G, J, K
 +/- .030 (0.76) ALLOWABLE MISALIGNMENT
 FROM CENTERLINE

790-036P SHELL SIZES A-F, J AND K										
Shell Size	A Max.		B Basic		C Basic		D Max.		E Max.	
	In.	mm.	In.	mm.	In.	mm.	In.	mm.	In.	mm.
A	1.211	30.76	.925	23.50	.565	14.35	.401	10.19	.805	20.45
B	1.361	34.57	1.075	27.31	.715	18.16	.551	14.00	.955	24.26
C	1.511	38.38	1.225	31.12	.865	21.97	.701	17.81	1.105	28.07
D	1.611	40.92	1.325	33.66	.965	24.51	.801	20.35	1.205	30.61
E	1.761	44.73	1.475	37.47	1.115	28.32	.951	24.16	1.355	34.42
F	1.911	48.54	1.625	41.28	1.265	32.13	1.101	27.96	1.505	38.23
J	2.261	57.43	1.975	50.17	1.615	41.02	1.460	37.08	1.855	47.12
K	2.661	67.59	2.375	60.33	2.015	51.18	1.860	47.24	2.255	57.28

Dimensions in Inches (millimeters) are subject to change without notice.



790-036P Shell Size G Dimensions

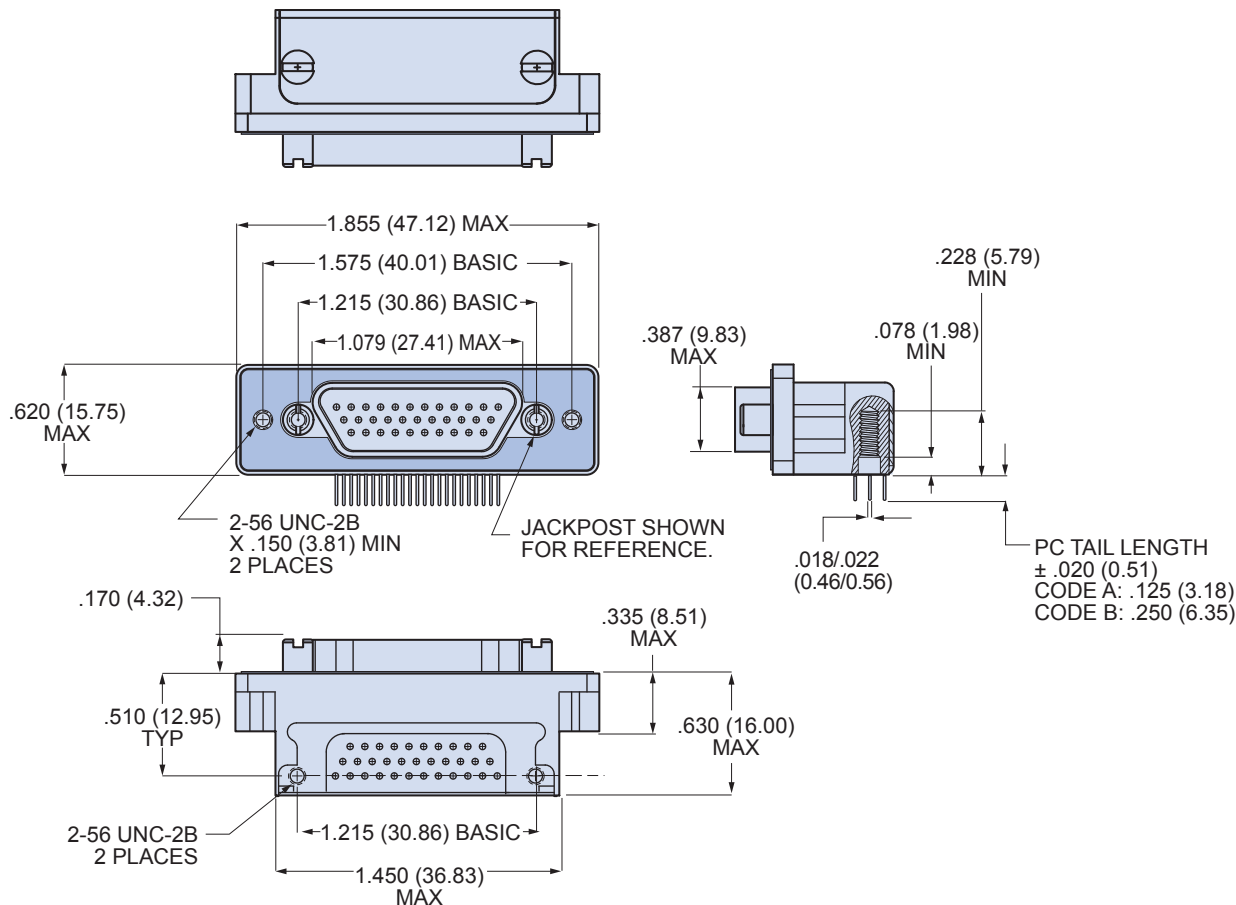

BLIND MATE

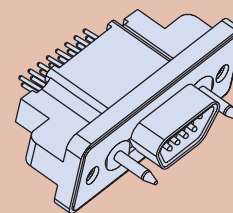

SHELL SIZES A, B, C, D, E, F, G, J, K
+/- .030 (0.76) ALLOWABLE MISALIGNMENT
FROM CENTERLINE

Dimensions in Inches (millimeters) are subject to change without notice.

790-036P Right Angle PCB Terminated Panel Mount Receptacle, Pin Contacts Dimensions



Series79
90° PCB
Connectors

790-036P Shell Sizes H and L Dimensions

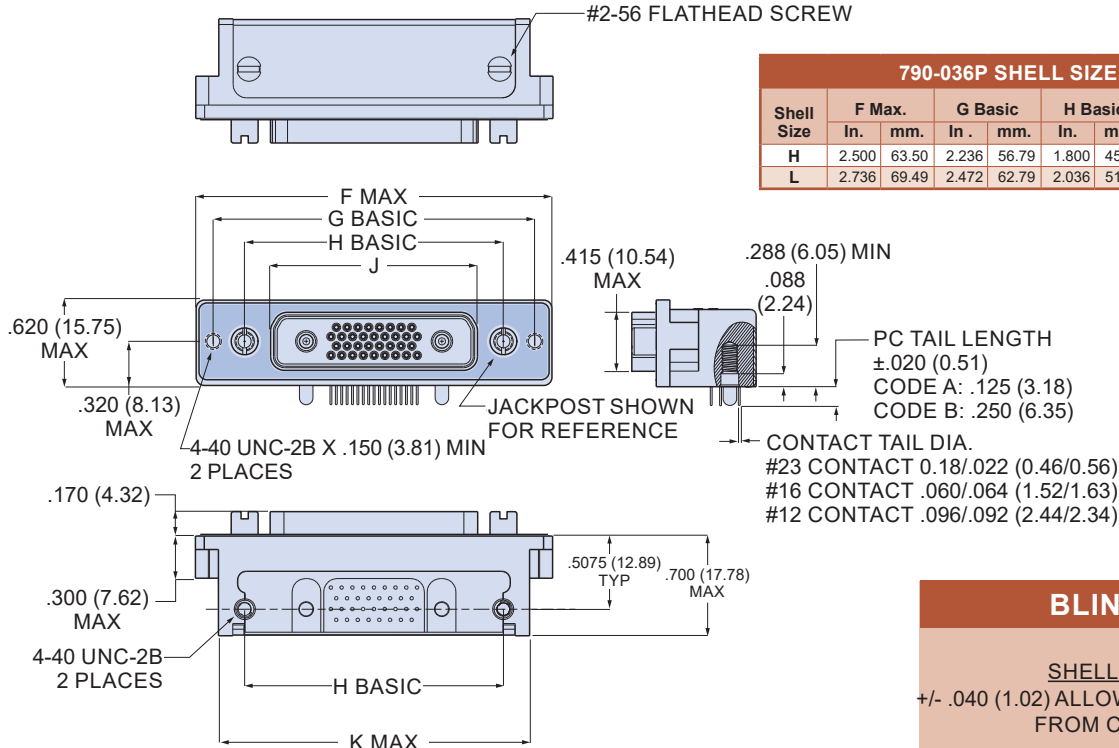

BLIND MATE

SHELL SIZES H, L
+/- .040 (1.02) ALLOWABLE MISALIGNMENT FROM CENTERLINE

790-036P Shell Size M Dimensions

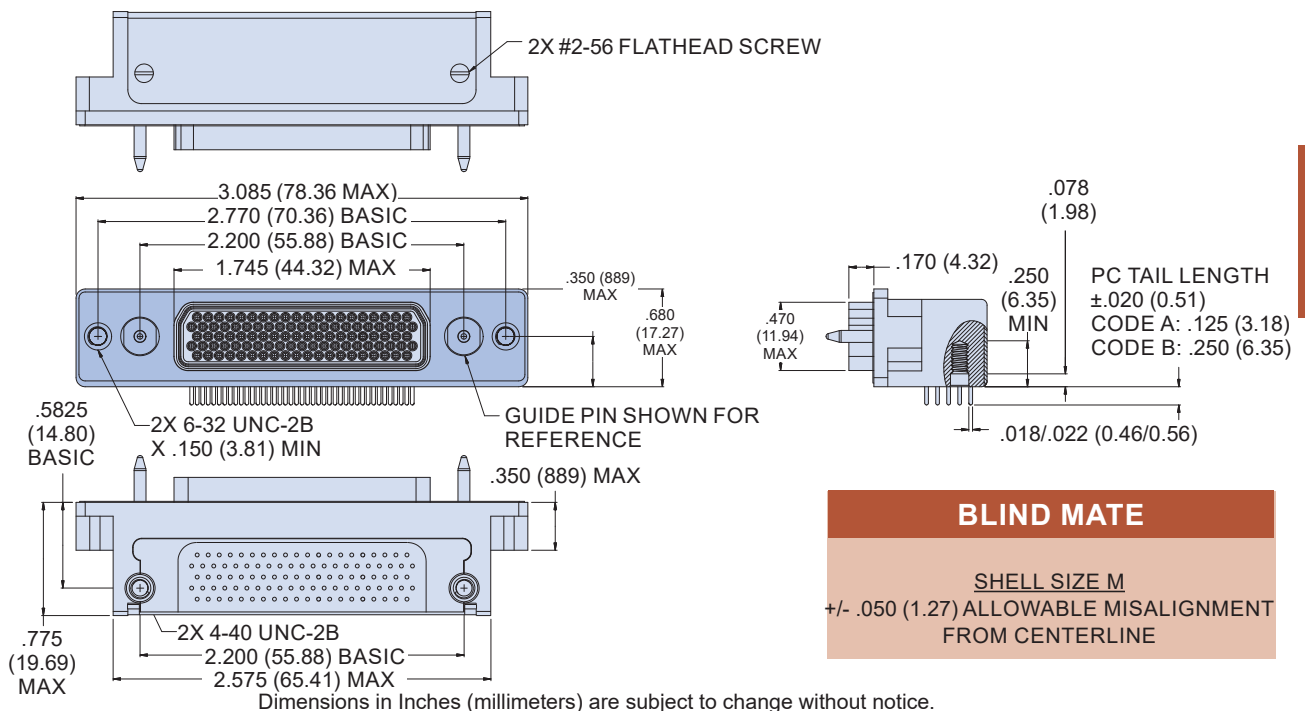

Dimensions in Inches (millimeters) are subject to change without notice.



790-041P
Right Angle PCB Terminated
Free-Standing Receptacle, Pin Contacts
How To Order

790-041P Right Angle Free-Standing Receptacles
PIN CONTACTS WITH RIGHT ANGLE PCB TERMINATION

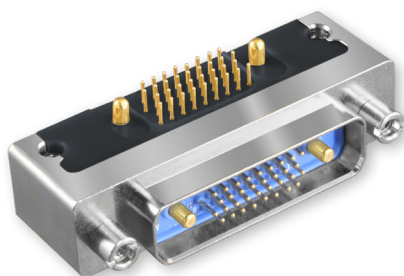

Lightweight, rugged right angle headers feature gold-plated contacts for thru-hole printed circuit board termination. 790-041P connectors are free-standing (not for panel mounting) and mate to 790-025S cable plugs. Contacts are permanently installed and are sealed with epoxy. Shells are aluminum alloy. Threaded board mounting holes and integral standoffs simplify installation. EMI shroud improves EMI performance. Fluorosilicone face seal provides watertight interface. Available in 29 different contact arrangements, these connectors feature size #23 signal contacts along with #16 and #12 power contacts for up to 23 amps current rating.

HOW TO ORDER

Sample Part Number				
790-041P	J-25P2	M	P	A
Part Number	Shell Size - Insert Arrangements	Shell Finish	Hardware Option	PC Tail Length
<p>790-041P Header Receptacle with 90° PC Tail Pin Contacts for Termination to Backplanes or Flexible Circuits</p>	<p>See Table 1 for Available Insert Arrangements</p>	<p>M Electroless Nickel <i>general purpose applications</i></p> <p>MT Nickel-PTFE 1000 Hour Grey™ <i>maximum corrosion protection and durability (non-reflective grey)</i></p> <p>ZNU Zinc-Nickel with Black Chromate <i>tactical applications (non-reflective black)</i></p> <p>Additional shell finishes are listed on page C-9.</p>	<p>N No Hardware</p> <p>P Female Jackpost</p>	<p>A .125 Inch (3.2 mm.)</p> <p>B .250 inch (6.4 mm.)</p>

SPECIFICATIONS

Current Rating	#23 5 AMPS, #16 13 A., #12 23 A.
Dielectric Withstanding Voltage	#23 500 VAC RMS, #12 and #16 1800 VAC RMS
Insulation Resistance	5000 megohms minimum
Operating Temperature	-65° C. to +150° C.
Shock	300 g.
Vibration	37 g.

MATERIALS AND FINISHES

Shell	Aluminum alloy
Contacts	Copper alloy, 50 microinches gold plated
Insulator	Liquid crystal polymer (LCP)
EMI Shroud	Aluminum alloy
Interfacial Seal	Flourosilicone rubber
Jackposts	300 series stainless steel
Tray	Thermoplastic
Encapsulant	Epoxy

Dimensions in Inches (millimeters) are subject to change without notice.

790-041P
Right Angle PCB Terminated
Free-Standing Receptacle, Pin Contacts
How To Order



Table Contact Arrangements

Layout	Contact Quantity		Face View
	#23	#16#12	
A-5	5		
B-2P2	2		
B-9	9		
C-13	13		
D-15	15		
D-3P3	3		
D-7P2	5	2	
E-11P2	9	2	
E-19	19		
E-7P3	4	3	
F-15P2	13	2	
F-23	23		
F-5P5		5	
G-33	33		
H-10P4	6	4	
H-29P7	22	7	
H-36P2	34	2	
H-54P2	52	2	
H-5P5		5	
H-66	66		
J-17P4	13	4	
J-25P2	23	2	
J-33	33		
J-7P7		7	
K-27P4	23	4	
K-35P2	33	2	
K-43	43		
K-9P9		9	
L-6P6		6	
L-78	78		
M-102	102		

CROSS-SECTIONAL VIEW OF 790-041P

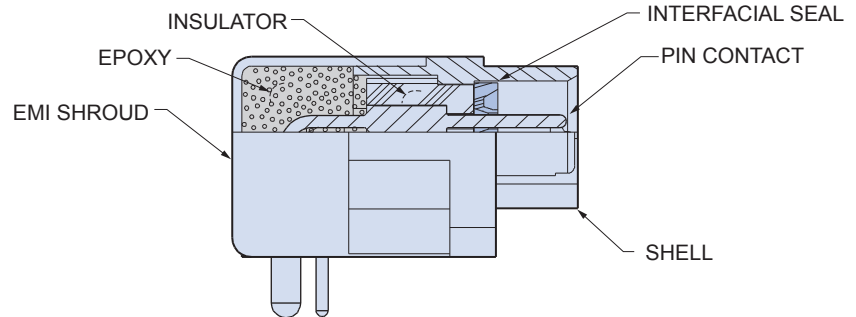
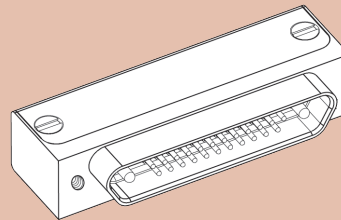

TABLE 2 HARDWARE OPTION



N

No Mating Hardware

Connector is supplied with blind, tapped holes. Shell size M have 8-32 UNC-2B thread, shell sizes H and L have 6-32 UNC-2B thread, other sizes are #4-40. aMinimum thread depth is .150" (3.81).

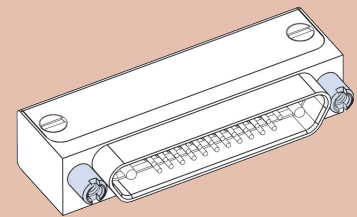

P

Jackposts

Connector is supplied with non-removable jackposts. Shell size M have 6-32 UNC-2B thread, shell sizes H and L have #4-40 UNC-2B thread, other sizes have #2-56 thread.

Dimensions in Inches (millimeters) are subject to change without notice.

790-041P Shell Sizes A-F, J and K Dimensions

790-041P SHELL SIZES A-F, J AND K

Shell Size	A Max.		B Basic		C Max.	
	In.	mm.	In.	mm.	In.	mm.
A	.805	20.45	.565	14.35	.401	10.19
B	.955	24.26	.715	18.16	.551	14.00
C	1.105	28.07	.865	21.97	.701	17.81
D	1.205	30.61	.965	24.51	.801	20.35
E	1.355	34.42	1.115	28.32	.951	24.16
F	1.505	38.23	1.265	32.13	1.101	27.96
J	1.855	47.12	1.615	41.02	1.460	37.08
K	2.255	57.28	2.015	51.18	1.860	47.24

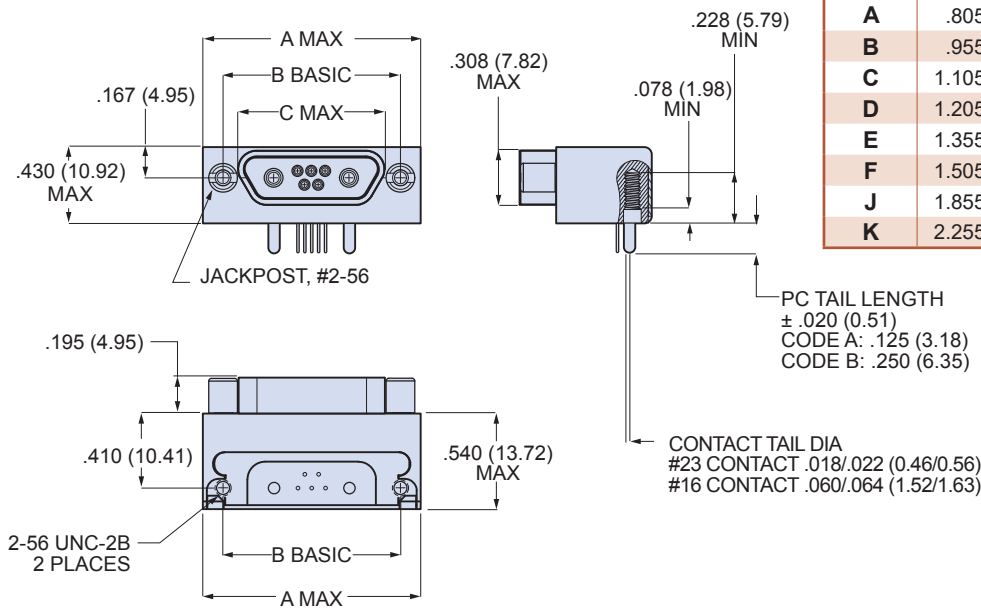

790-041P Shell Size G Dimensions

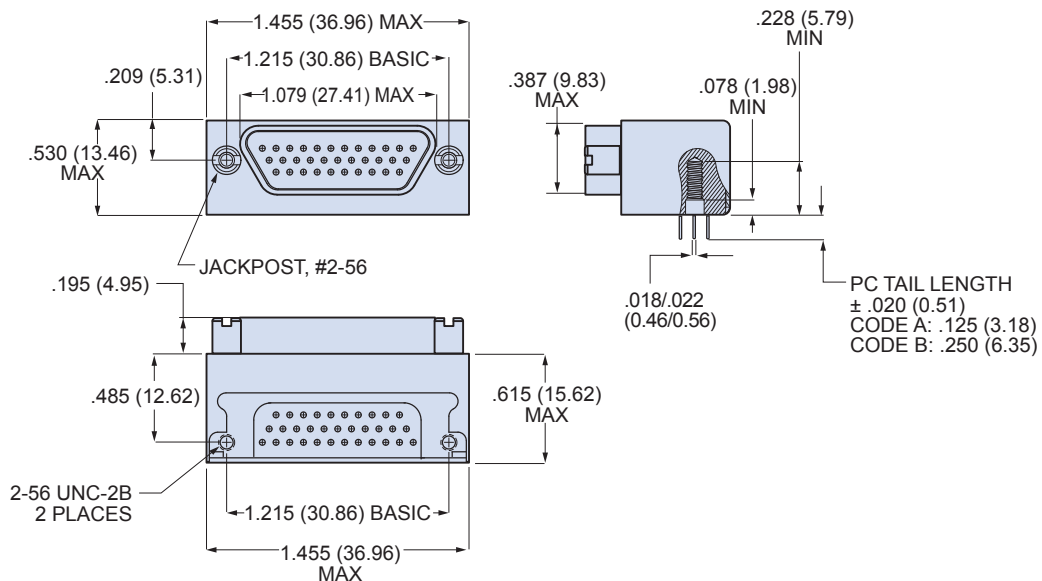

Dimensions in Inches (millimeters) are subject to change without notice.

790-041P
Right Angle PCB Terminated
Free-Standing Receptacle, Pin Contacts
Dimensions



790-041P Shell Sizes H & L Dimensions

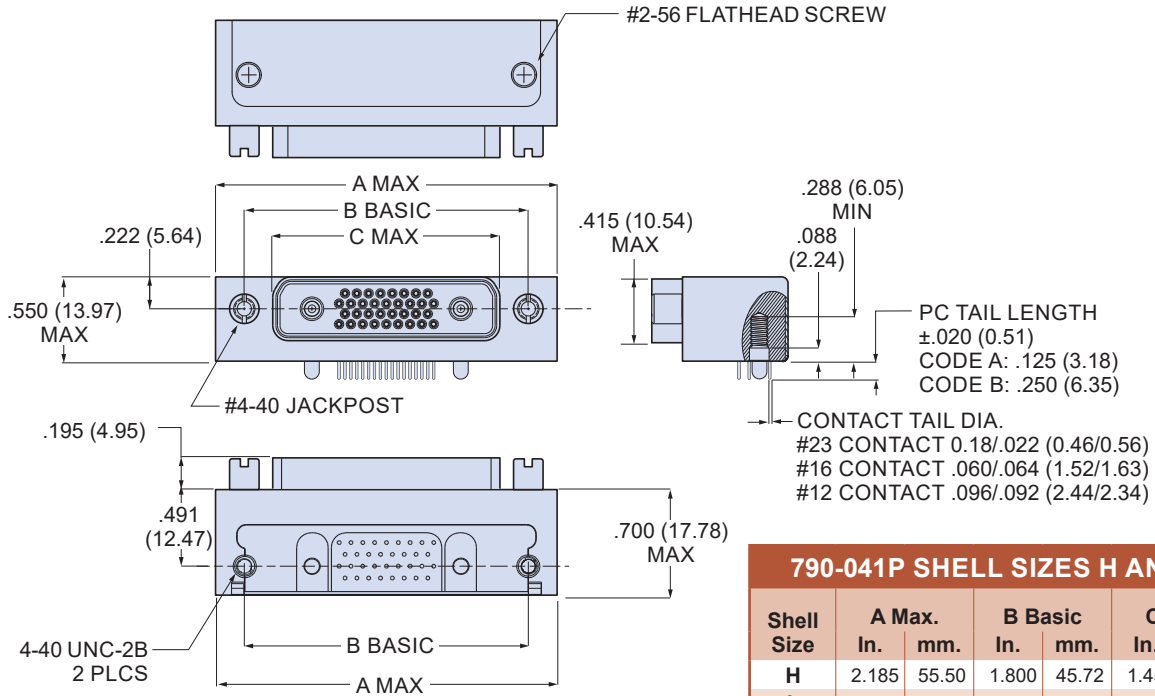

790-041P SHELL SIZES H AND L						
Shell Size	A Max.		B Basic		C Max.	
	In.	mm.	In.	mm.	In.	mm.
H	2.185	55.50	1.800	45.72	1.450	36.83
L	2.430	61.72	2.036	51.71	1.686	42.82

790-041P Shell Size M Dimensions

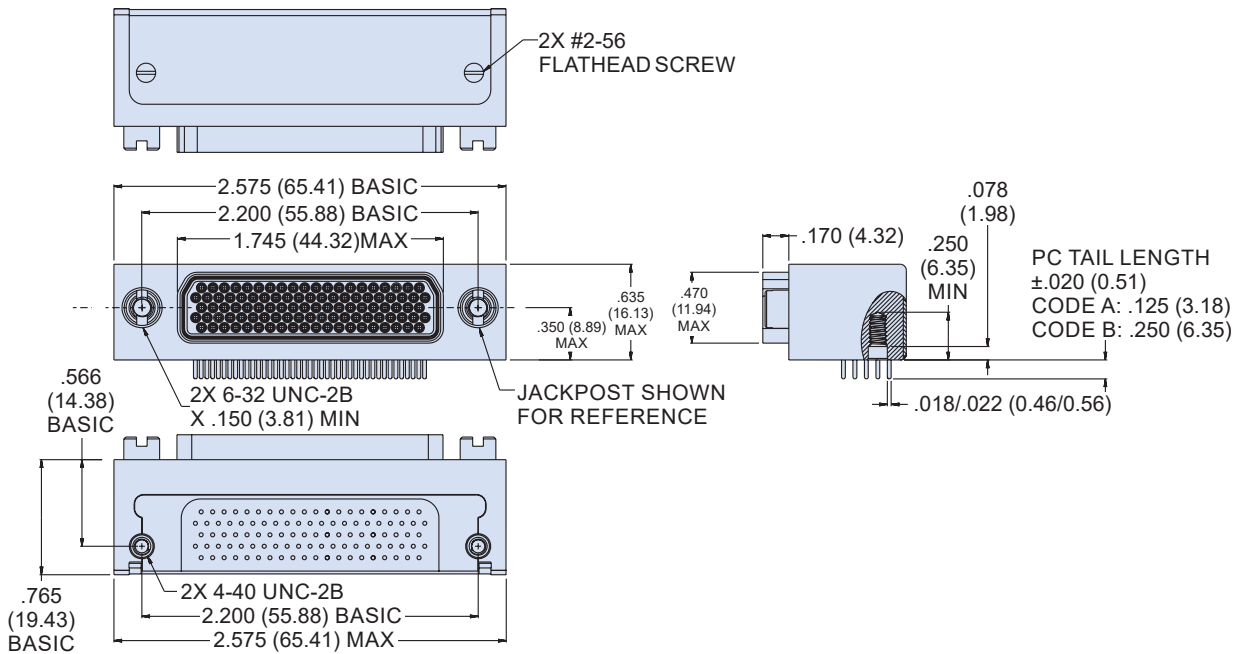

Dimensions in Inches (millimeters) are subject to change without notice.



790-036P and 790-041P
Right Angle PCB Connectors
Receptacle PCB Hole Patterns

790-036P and 790-041P Receptacle PCB Hole Patterns

This section contains printed circuit board footprints for right angle Series 79 receptacles. The contact identification numbers are shown for the connector mounting side of the PCB. Contact tails are gold over nickel plated.

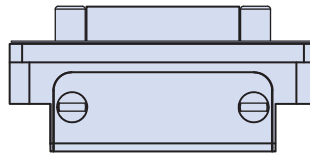

CONNECTOR ORIENTATION

Contact Size	PC Tail Diameter	
	Ø Diameter In.	Ø Diameter mm.
#23	.018-.022	0.46-0.56
#16	.060-.064	1.52-1.63
#12	.092-.096	2.34-2.44

790-036P AND 790-041P PRINTED CIRCUIT BOARD PATTERNS

Insert Arr.

Component Mounting Side of PCB
Mating Face of Connector is Toward Top of Page

A-5

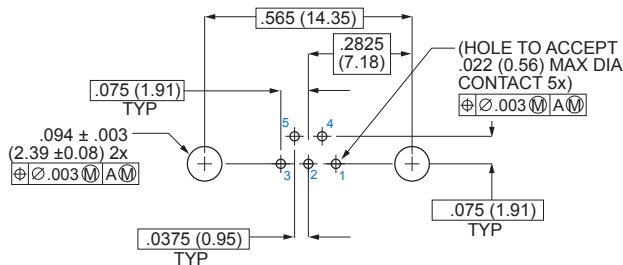

B-2P2

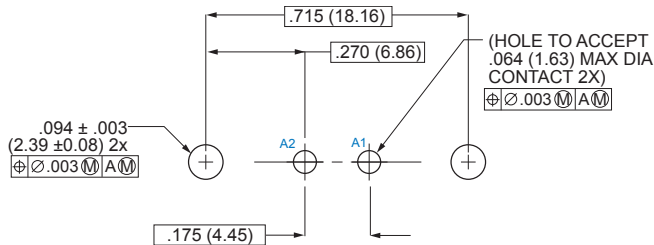

B-9

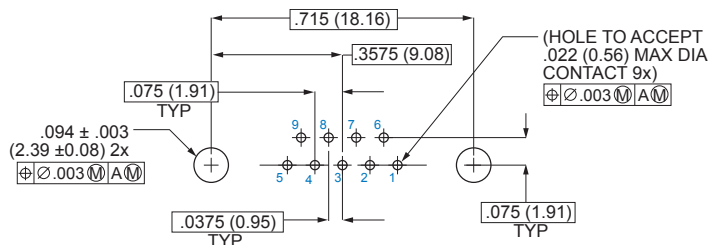

C-13

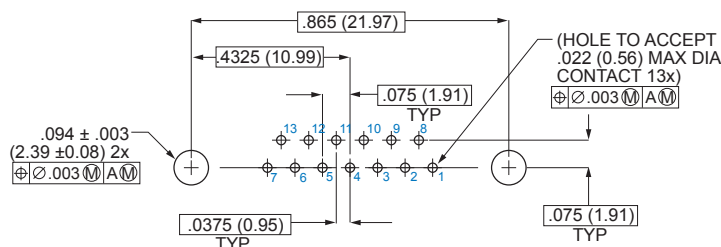

Dimensions in Inches (millimeters) are subject to change without notice.

790-036P and 790-041P
Right Angle PCB Connectors
Receptacle PCB Hole Patterns



Series79
90° PCB
Connectors

790-036P AND 790-041P PRINTED CIRCUIT BOARD PATTERNS

Insert Arr.	Component Mounting Side of PCB Mating Face of Connector is Toward Top of Page
D-15	
D-3P3	
D-7P2	
E-11P2	
E-19	

Dimensions in Inches (millimeters) are subject to change without notice.



790-036P AND 790-041P PRINTED CIRCUIT BOARD PATTERNS

Insert Arr.	Component Mounting Side of PCB Mating Face of Connector is Toward Top of Page
E-7P3	
F-15P2	
F-23	
F-5P5	
G-33	

Dimensions in Inches (millimeters) are subject to change without notice.

790-036P and 790-041P
Right Angle PCB Connectors
Receptacle PCB Hole Patterns



Series79
90° PCB
Connectors

790-036P AND 790-041P PRINTED CIRCUIT BOARD PATTERNS

Insert Arr.	Component Mounting Side of PCB Mating Face of Connector is Toward Top of Page
H-10P4	
H-29P7	
H-36P2	
H-54P2	
H-5P5	

Dimensions in Inches (millimeters) are subject to change without notice.



790-036P AND 790-041P PRINTED CIRCUIT BOARD PATTERNS

Insert Arr.	Component Mounting Side of PCB Mating Face of Connector is Toward Top of Page
H-66	
J-17P4	
J-25P2	
J-33	
J-7P7	
K-27P4	

Dimensions in Inches (millimeters) are subject to change without notice.

790-036P and 790-041P
Right Angle PCB Connectors
Receptacle PCB Hole Patterns



Series79
90° PCB
Connectors

790-036P AND 790-041P PRINTED CIRCUIT BOARD PATTERNS

Insert Arr.	Component Mounting Side of PCB Mating Face of Connector is Toward Top of Page
K-35P2	
K-43	
K-9P9	
L-6P6	
L-78	
M-102	

Dimensions in Inches (millimeters) are subject to change without notice.





790-037S
Right Angle PCB Terminated
Panel Mount Plugs, Socket Contacts
How To Order

790-037S Right Angle PCB Panel Mount Plugs

SOCKET CONTACTS WITH RIGHT ANGLE PCB TERMINATION



Lightweight, rugged right angle headers feature gold-plated PC tail contacts for thru-hole printed circuit board termination. 790-037S connectors are designed for rear-panel mounting and are supplied with conductive panel gaskets. Contacts are permanently installed and are sealed with epoxy. Shells are aluminum alloy. EMI shroud improves shielding performance. Threaded board mounting holes and integral standoffs simplify installation. Available in 29 different contact arrangements, these connectors feature size #23 signal contacts along with #16 and #12 power contacts for up to 23 amps current rating. Optional EMI spring improves shell-to-shell conductivity and shielding performance.

HOW TO ORDER

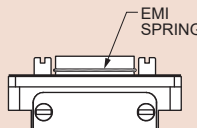
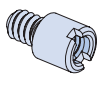
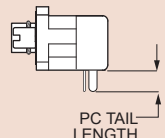
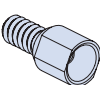
Sample Part Number					
790-037S	H-5P5	M	E	P	B
Part Number	Shell Size - Insert Arrangements	Shell Finish	EMI Spring	Hardware Option	PC Tail Length
790-037S Rear Panel Mounted Plug with 90° PC Tail Contacts for Termination to Backplanes or Flexible Circuits	See Table 1 for Available Insert Arrangements	M Electroless Nickel <i>general purpose applications</i>	E EMI Spring	 N No Hardware	A .125 Inch (3.2 mm.)
		MT Nickel-PTFE <i>1000 Hour Grey™ maximum corrosion protection and durability (non-reflective grey)</i>	N No Spring	 G Guide Pin	B .250 inch (6.4 mm.)
		ZNU Zinc-Nickel with Black Chromate <i>tactical applications (non-reflective black)</i>	Note: EMI Spring is not compatible with chromate finishes including cadmium and zinc-nickel	 P Female Jackpost	 PC TAIL LENGTH
		Additional shell finishes are listed on page C-9.		 S Female Guide Socket	

SPECIFICATIONS

Current Rating	#23 5 AMPS, #16 13 A., #12 23 A.
Dielectric Withstanding Voltage	#23 500 VAC RMS, #12 and #16 1800 VAC RMS
Insulation Resistance	5000 megohms minimum
Operating Temperature	-65° C. to +150° C.
Shock	300 g.
Vibration	37 g.

MATERIALS AND FINISHES

Shell	Aluminum alloy
Contacts	Copper alloy, gold plated, with stainless steel hood
Insulator	Liquid crystal polymer (LCP)
PCB Tray	Thermoplastic
EMI Shroud	Aluminum alloy
Hardware	300 series stainless steel
Panel Gasket	Fluorosilicone, conductive
Encapsulant	Epoxy

Dimensions in Inches (millimeters) are subject to change without notice.

790-037S

Right Angle PCB Terminated Panel Mount Plugs, Socket Contacts How To Order



Series79
90° PCB
Connectors

Table Contact Arrangements

Layout	Contact Quantity			Face View
	#23	#16	#12	
A-5	5			
B-2P2	2			
B-9	9			
C-13	13			
D-15	15			
D-3P3	3			
D-7P2	5	2		
E-11P2	9	2		
E-19	19			
E-7P3	4	3		
F-15P2	13	2		
F-23	23			
F-5P5	5			
G-33	33			
H-10P4	6	4		
H-29P7	22	7		
H-36P2	34	2		
H-54P2	52	2		
H-5P5		5		
H-66	66			
J-17P4	13	4		
J-25P2	23	2		
J-33	33			
J-7P7	7			
K-27P4	23	4		
K-35P2	33	2		
K-43	43			
K-9P9	9			
L-6P6		6		
L-78	78			
M-102	102			

CROSS-SECTIONAL VIEW OF 790-037S

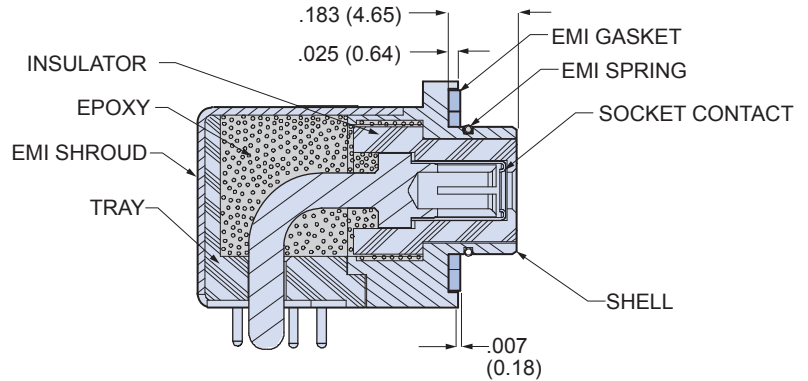

**TABLE 2
HARDWARE OPTION**

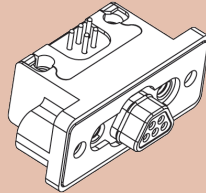

N

No Mating Hardware

Connector is supplied with blind, tapped holes. Shell size M have 8-32 UNC-2B thread, shell sizes H and L have 6-32 UNC-2B thread, other sizes are #4-40. Minimum thread depth is .150" (3.81).

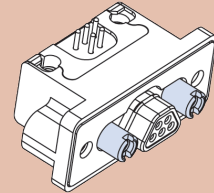

P

Jackposts

Connector is supplied with non-removable jackposts. Shell size M have 6-32 UNC-2B thread, shell sizes H and L have #4-40 UNC-2B thread, other sizes have #2-56 thread.

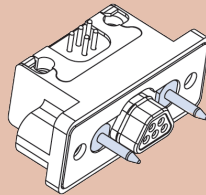

G

Male Guide Pins

Connector is supplied with stainless steel guide pins to mate with code S guide sockets. Pins are non-removable.

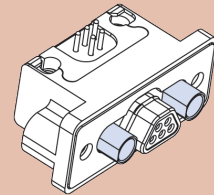

S

Female Guide Sockets

Connector is supplied with stainless steel guide sockets to mate with code G guide pins. Sockets are non-removable.

Dimensions in Inches (millimeters) are subject to change without notice.

G



790-037S Right Angle PCB Terminated Panel Mount Plugs, Socket Contacts Dimensions

790-037S Shell Sizes A-F, J and K Dimensions

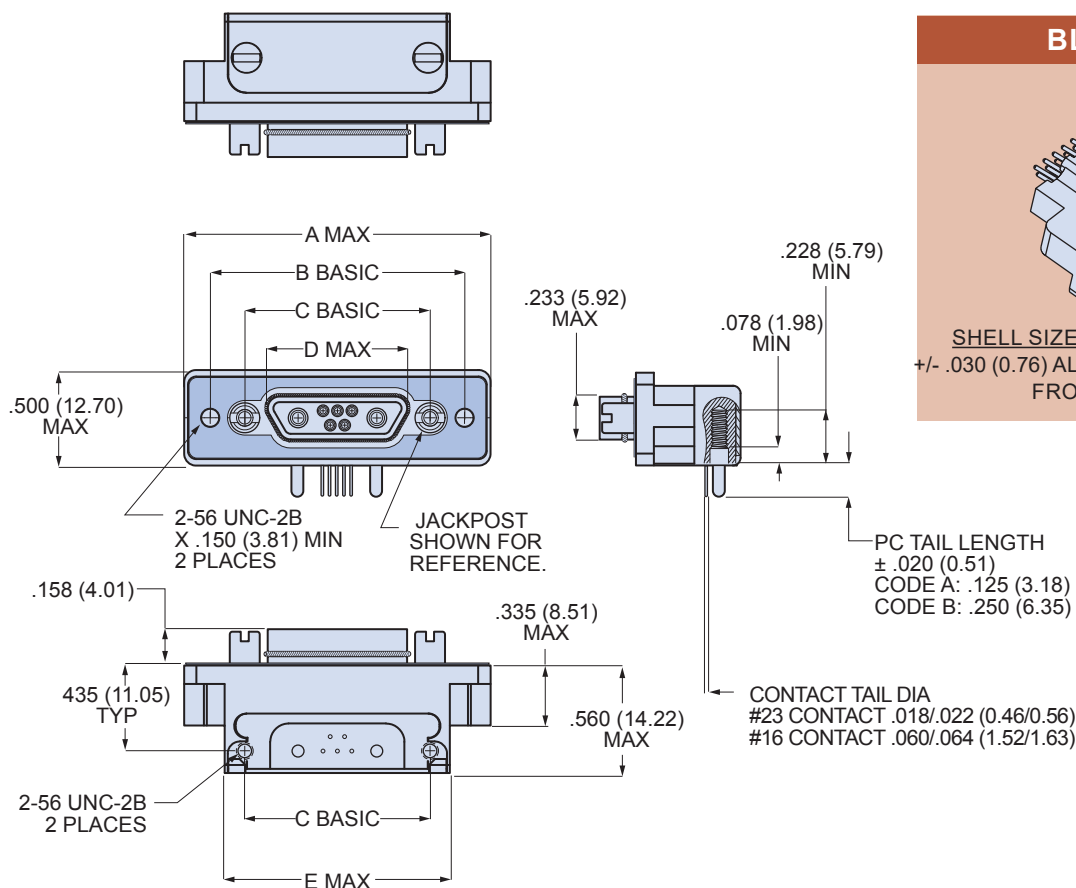

BLIND MATE

SHELL SIZES A, B, C, D, E, F, G, J, K
+/- .030 (0.76) ALLOWABLE MISALIGNMENT
FROM CENTERLINE

790-037S SHELL SIZES A-F, J AND K

Shell Size	A Max.		B Basic		C Basic		D Max.		E Max.	
	In.	mm.	In.	mm.	In.	mm.	In.	mm.	In.	mm.
A	1.211	30.76	.925	23.50	.565	14.35	.335	8.51	.805	20.45
B	1.361	34.57	1.075	27.31	.715	18.16	.485	12.32	.955	24.26
C	1.511	38.38	1.225	31.12	.865	21.97	.635	16.13	1.105	28.07
D	1.611	40.92	1.325	33.66	.965	24.51	.735	18.67	1.205	30.61
E	1.761	44.73	1.475	37.47	1.115	28.32	.885	22.48	1.355	34.42
F	1.911	48.54	1.625	41.28	1.265	32.13	1.035	26.29	1.505	38.23
J	2.261	57.43	1.975	50.17	1.615	41.02	1.380	35.05	1.855	47.12
K	2.661	67.59	2.375	60.33	2.015	51.18	1.783	45.29	2.255	57.28

Dimensions in Inches (millimeters) are subject to change without notice.

790-037S
Right Angle PCB Terminated
Panel Mount Plugs, Socket Contacts
Dimensions



Series79
 90° PCB
 Connectors

790-037S Shell Size G Dimensions

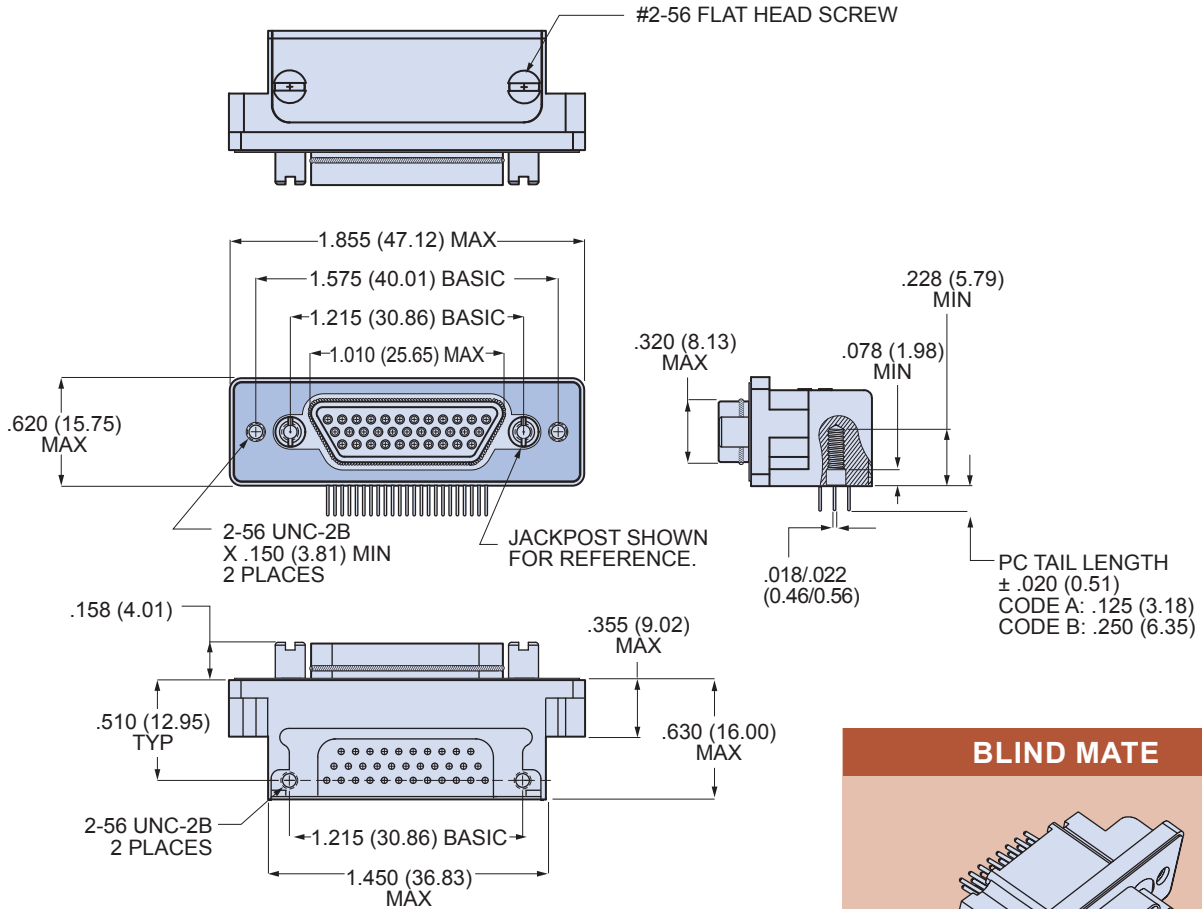

BLIND MATE

SHELL SIZES A, B, C, D, E, F, G, J, K
 +/- .030 (0.76) ALLOWABLE MISALIGNMENT FROM CENTERLINE



Dimensions in Inches (millimeters) are subject to change without notice.



790-037S Right Angle PCB Terminated Panel Mount Plugs, Socket Contacts Dimensions

790-037S Shell Sizes H and L Dimensions

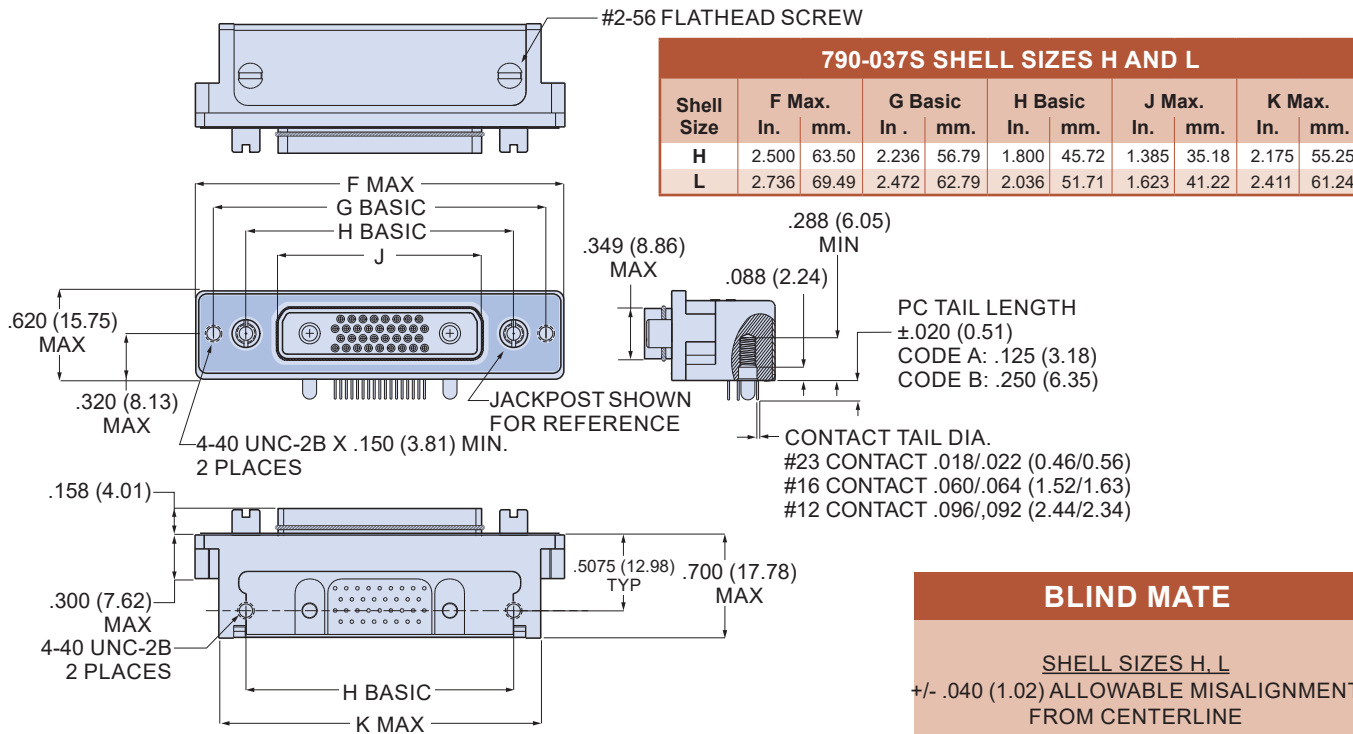

790-037S Shell Size M Dimensions

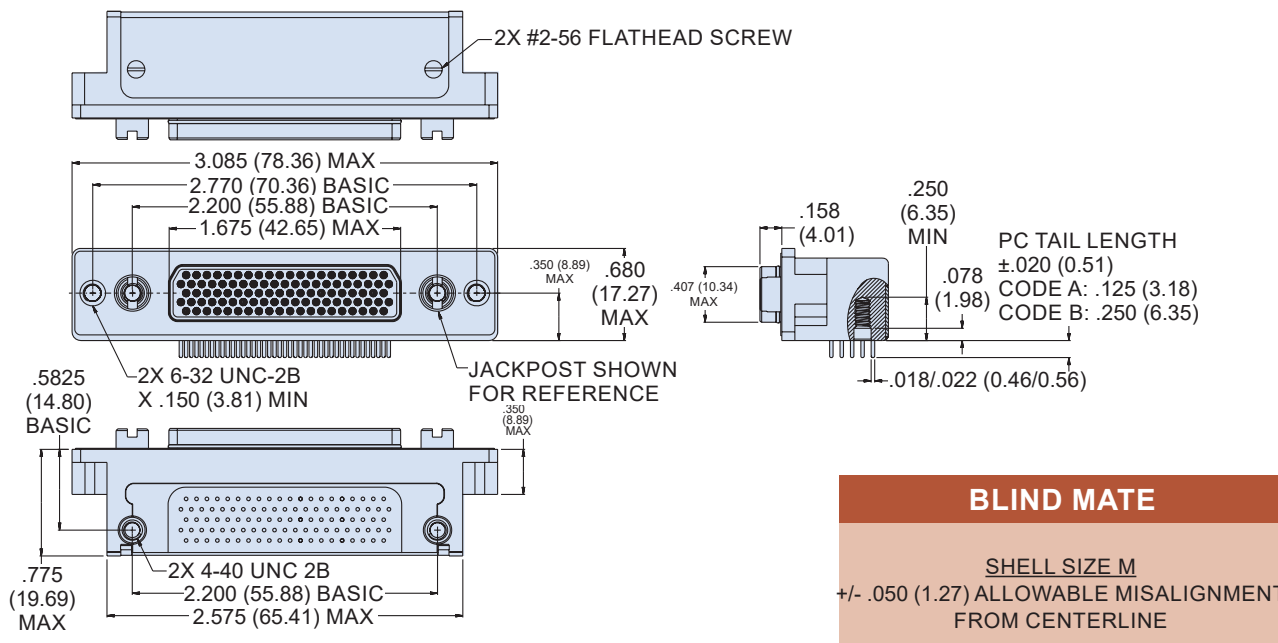

Dimensions in Inches (millimeters) are subject to change without notice.

790-042S
Right Angle PCB Terminated
Free-Standing Plugs, Socket Contacts
How To Order



790-042S Right Angle PCB Free-Standing Plugs
SOCKET CONTACTS WITH PCB TERMINATION

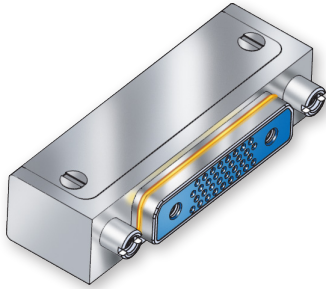

Free-standing rugged right angle headers feature gold-plated PC tail contacts for thru-hole printed circuit board termination. Not for panel mounting. Contacts are permanently installed and are sealed with epoxy. Shells are aluminum alloy. EMI shroud improves shielding performance. Threaded board mounting holes and integral standoffs simplify installation. Available in 29 different contact arrangements, these connectors feature size #23 signal contacts along with #16 and #12 power contacts for up to 23 amps current rating. Optional EMI spring improves shell-to-shell conductivity and shielding performance. Mates with 790-024p cable receptacles.

HOW TO ORDER

Sample Part Number

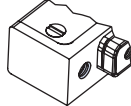
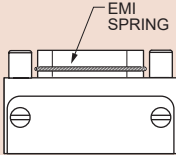
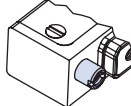
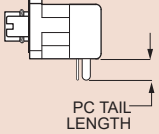
790-042S	L-6P6	M	E	P	A
Part Number	Shell Size - Insert Arrangements	Shell Finish	EMI Spring	Hardware Option	PC Tail Length
790-042S Right Angle Plug with 90° PC Tail Contacts for Termination to Backplanes or Flexible Circuits	See Table 1 for Available Insert Arrangements	M Electroless Nickel <i>general purpose applications</i>	E EMI Spring		A .125 Inch (3.2 mm.)
		MT Nickel-PTFE 1000 Hour Grey™ <i>maximum corrosion protection and durability (non-reflective grey)</i>	N No Spring		B .250 inch (6.4 mm.)
		ZNU Zinc-Nickel with Black Chromate <i>tactical applications (non-reflective black)</i> Additional shell finishes are listed on page C-9.	Note: EMI Spring is not compatible with chromate finishes including cadmium and zinc-nickel		

SPECIFICATIONS

Current Rating	#23 5 AMPS, #16 13 A., #12 23 A.
Dielectric Withstanding Voltage	#23 500 VAC RMS, #12 and #16 1800 VAC RMS
Insulation Resistance	5000 megohms minimum
Operating Temperature	-65° C. to +150° C.
Shock	300 g.
Vibration	37 g.

MATERIALS AND FINISHES

Shell	Aluminum alloy
Contacts	Copper alloy, gold plated
Insulator	Liquid crystal polymer (LCP)
PCB Tray	Thermoplastic
EMI Shroud	Aluminum alloy
Hardware	300 series stainless steel
Panel Gasket	Fluorosilicone, conductive
Encapsulant	Epoxy

Dimensions in Inches (millimeters) are subject to change without notice.



790-042S Right Angle PCB Terminated Free-Standing Plugs, Socket Contacts How To Order

Table Contact Arrangements

Layout	Contact Quantity		Face View
	#23	#16#12	
A-5	5		
B-2P2	2		
B-9	9		
C-13	13		
D-15	15		
D-3P3	3		
D-7P2	5	2	
E-11P2	9	2	
E-19	19		
E-7P3	4	3	
F-15P2	13	2	
F-23	23		
F-5P5	5		
G-33	33		
H-10P4	6	4	
H-29P7	22	7	
H-36P2	34	2	
H-54P2	52	2	
H-5P5		5	
H-66	66		
J-17P4	13	4	
J-25P2	23	2	
J-33	33		
J-7P7	7		
K-27P4	23	4	
K-35P2	33	2	
K-43	43		
K-9P9	9		
L-6P6		6	
L-78	78		
M-102	102		

CROSS-SECTIONAL VIEW OF 790-042S

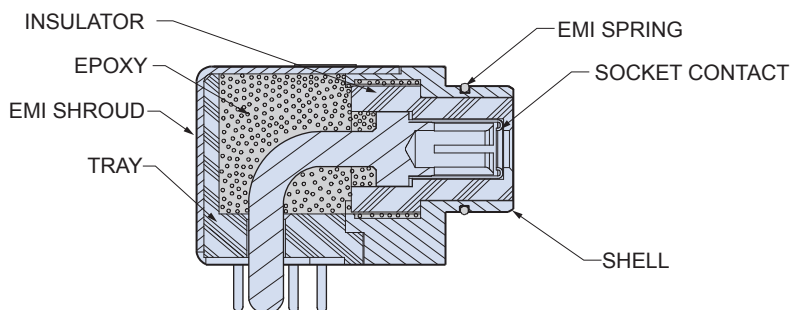
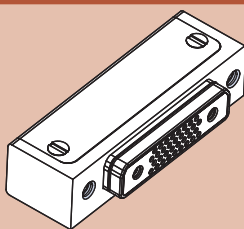

TABLE 2 HARDWARE OPTION



N

No Mating Hardware

Connector is supplied with blind, tapped holes. Shell size M have 8-32 UNC-2B thread, shell sizes H and L have 6-32 UNC-2B thread, other sizes are #4-40. Minimum thread depth is .150" (3.81).

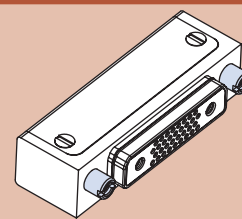

P

Jackposts

Connector is supplied with non-removable jackposts. Shell size M have 6-32 UNC-2B thread, shell sizes H and L have #4-40 UNC-2B thread, other sizes have #2-56 thread.

Dimensions in Inches (millimeters) are subject to change without notice.

790-042S
Right Angle PCB Terminated
Free-Standing Plugs, Socket Contacts
Dimensions



790-042S Shell Sizes A-F, J and K Dimensions

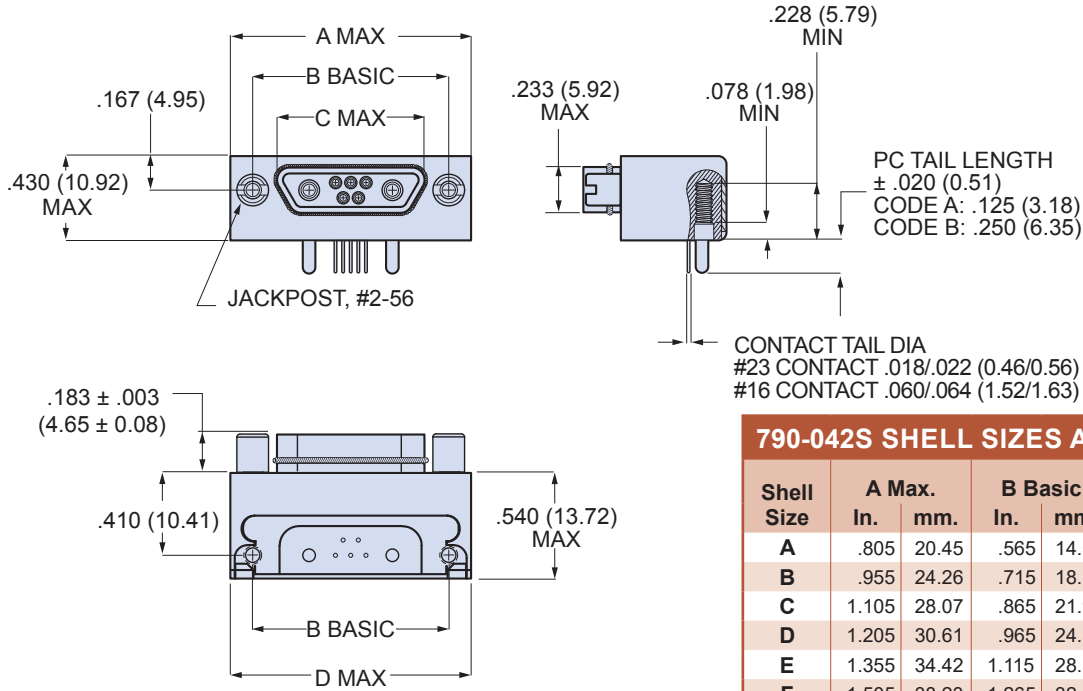

790-042S SHELL SIZES A-F, J AND K

Shell Size	A Max.		B Basic		C Max.	
	In.	mm.	In.	mm.	In.	mm.
A	.805	20.45	.565	14.35	.335	8.51
B	.955	24.26	.715	18.16	.485	12.32
C	1.105	28.07	.865	21.97	.635	16.13
D	1.205	30.61	.965	24.51	.735	18.67
E	1.355	34.42	1.115	28.32	.885	22.48
F	1.505	38.23	1.265	32.13	1.035	26.29
J	1.855	47.12	1.615	41.02	1.380	35.05
K	2.255	57.28	2.015	51.18	1.783	45.29

790-042S Shell Size G Dimensions

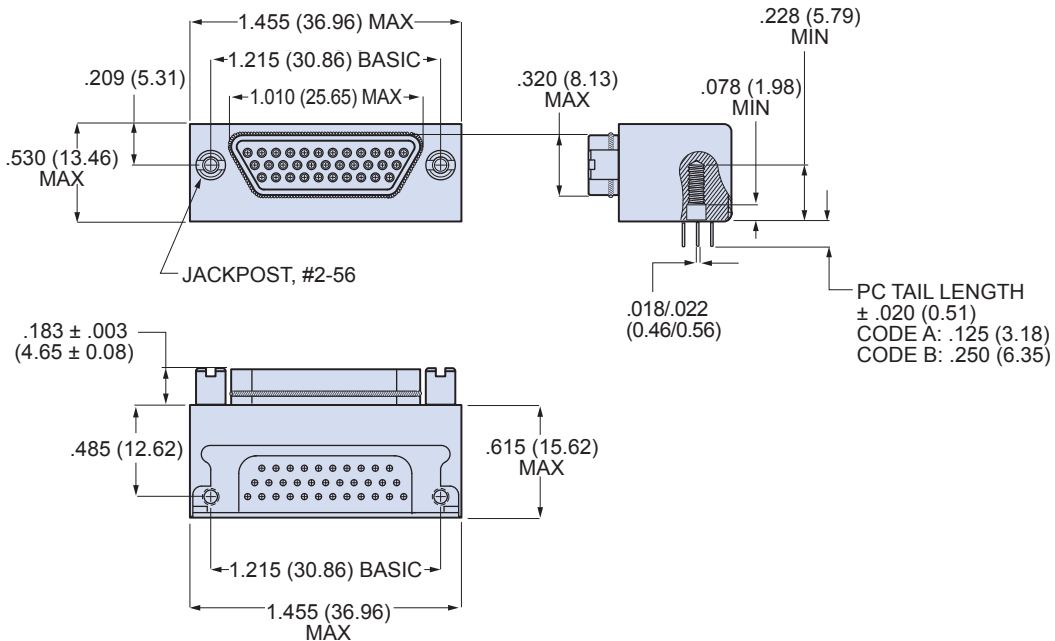

Dimensions in Inches (millimeters) are subject to change without notice.



790-042S Shell Sizes H and L Dimensions

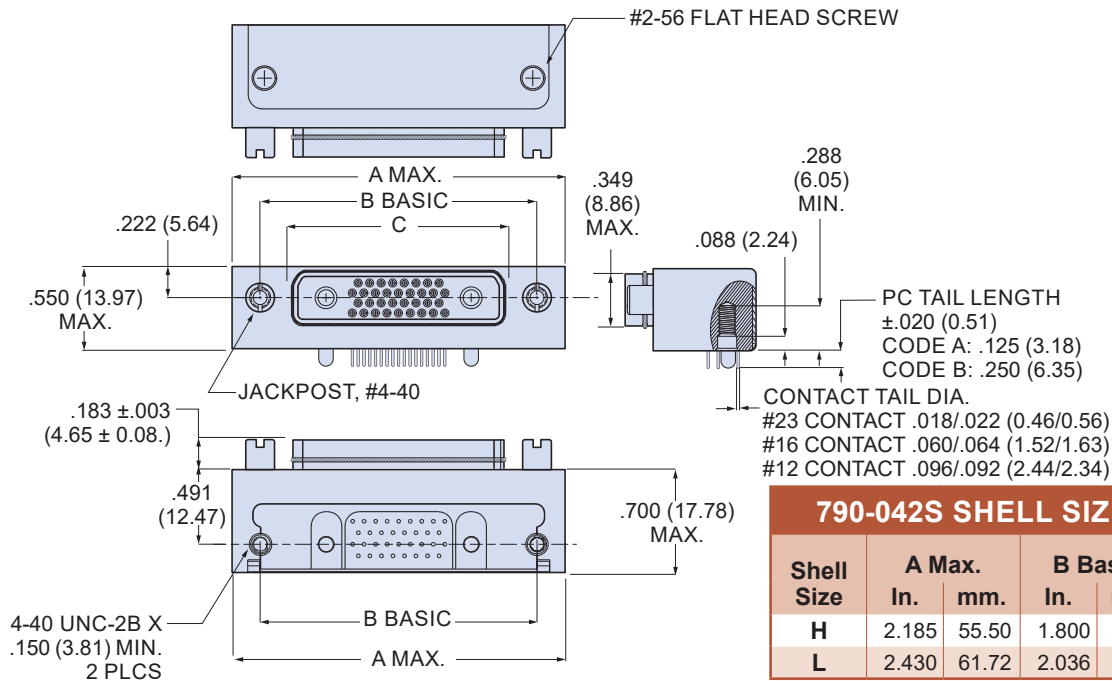

790-042S Shell Size M Dimensions

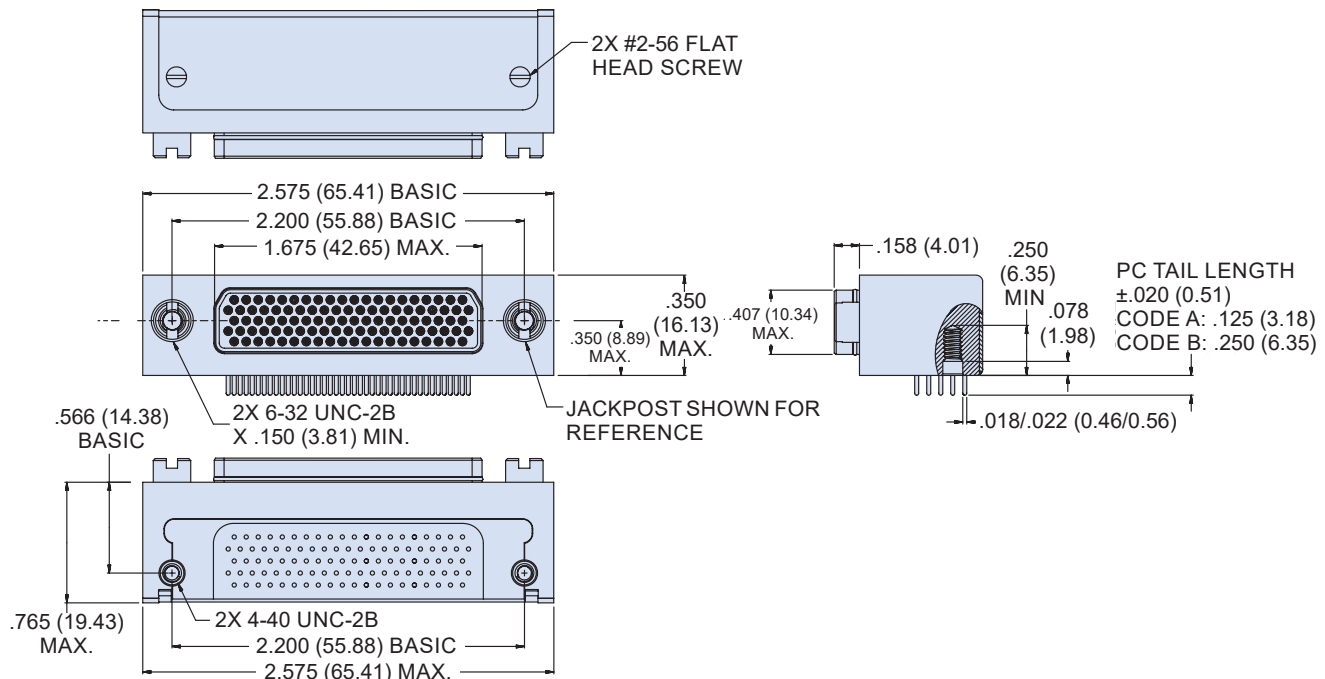

Dimensions in Inches (millimeters) are subject to change without notice.

790-037S and 790-042S Right Angle PCB Connectors Plug PCB Hole Patterns



Series79
90° PCB
Connectors

790-037S and 790-042S Plug Hole Patterns

This section contains printed circuit board footprints for right angle Series 79 plugs. The contact identification numbers are shown for the connector mounting side of the PC board. Contact tails are gold over nickel plated.

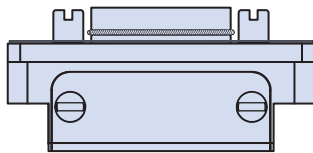

CONNECTOR ORIENTATION

Contact Size	PC Tail Diameter	
	Ø Diameter In.	Ø Diameter mm.
#23	.018-.022	0.46-0.56
#16	.060-.064	1.52-1.63
#12	.092-.096	2.34-2.44

790-037S AND 790-042S PRINTED CIRCUIT BOARD PATTERNS

Insert Arr.	Component Mounting Side of PCB Mating Face of Connector is Toward Top of Page
A-5	
B-2P2	
B-9	
C-13	

Dimensions in Inches (millimeters) are subject to change without notice.



790-037S AND 790-042S PRINTED CIRCUIT BOARD PATTERNS

Insert Arr.	Component Mounting Side of PCB Mating Face of Connector is Toward Top of Page
D-15	
D-3P3	
D-7P2	
E-11P2	
E-19	

Dimensions in Inches (millimeters) are subject to change without notice.

790-037S and 790-042S Right Angle PCB Connectors Plug PCB Hole Patterns



Series79
90° PCB
Connectors

790-037S AND 790-042S PRINTED CIRCUIT BOARD PATTERNS

Insert Arr.	Component Mounting Side of PCB Mating Face of Connector is Toward Top of Page
E-7P3	
F-15P2	
F-23	
F-5P5	
G-33	

Dimensions in Inches (millimeters) are subject to change without notice.





790-037S and 790-042S Right Angle PCB Connectors Plug PCB Hole Patterns

790-037S AND 790-042S PRINTED CIRCUIT BOARD PATTERNS

Insert Arr.	Component Mounting Side of PCB Mating Face of Connector is Toward Top of Page
H-10P4	
H-29P7	
H-36P2	
H-54P2	
H-5P5	

Dimensions in Inches (millimeters) are subject to change without notice.

790-037S and 790-042S Right Angle PCB Connectors Plug PCB Hole Patterns



Series79
90° PCB
Connectors

790-037S AND 790-042S PRINTED CIRCUIT BOARD PATTERNS

Insert Arr.	Component Mounting Side of PCB Mating Face of Connector is Toward Top of Page
H-66	
J-17P4	
J-25P2	
J-33	
J-7P7	
K-27P4	

Dimensions in Inches (millimeters) are subject to change without notice.





790-037S and 790-042S Right Angle PCB Connectors Plug PCB Hole Patterns

790-037S AND 790-042S PRINTED CIRCUIT BOARD PATTERNS

Insert Arr.	Component Mounting Side of PCB Mating Face of Connector is Toward Top of Page
K-35P2	
K-43	
K-9P9	
L-6P6	
L-78	
M-102	

Dimensions in Inches (millimeters) are subject to change without notice.

799-015
Low Profile EMI Backshell
for 790-024 and 790-025 Cable Connectors
How To Order







799-015 Low Profile EMI Backshell
FOR 790-024 AND 790-025 CABLE CONNECTORS

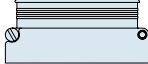

Attach cable braid to connector with 799-015 adapters. These adapters fit securely into a groove on 790-024 and 790-025 cable connectors. Terminate shields with **BAND-IT**® 300 Series SST/Passivate I.A.W. AMS 2700. Elliptical cable entry provides room for large wire bundles. Machined T6061 aluminum adapters consist of two interlocking housings, two fillister head screws and two lockwashers. These lightweight, space-saving adapters are compatible with captive screws on connector flange. This adapter is non environmental. Fill with potting compound to prevent water intrusion.

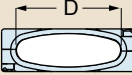
How To Order

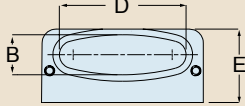
How To Order																																																									
Sample Part Number																																																									
799-015T	M	B	02	N	02																																																				
Part Number	Shell Finish	Shell Size	Cable Entry Size	Band Option	Optional Height Code*																																																				
 799-015T Top Entry  799-015S Side Entry	M Electroless Nickel <i>general purpose applications</i> MT Nickel-PTFE 1000 Hour Grey™ <i>maximum corrosion protection and durability (non-reflective grey)</i>	A		N No Band Supplied M BAND-IT ™ Micro-Band Included. .125 (3.18) Wide. 	 <table border="1"> <thead> <tr> <th rowspan="2">Height Code</th> <th colspan="2">E</th> </tr> <tr> <th>In.</th> <th>mm.</th> </tr> </thead> <tbody> <tr><td>01</td><td>.810</td><td>20.6</td></tr> <tr><td>02</td><td>.940</td><td>23.9</td></tr> <tr><td>03</td><td>1.060</td><td>26.9</td></tr> <tr><td>04</td><td>1.190</td><td>30.2</td></tr> <tr><td>05</td><td>1.310</td><td>33.3</td></tr> <tr><td>06</td><td>1.440</td><td>36.6</td></tr> <tr><td>07</td><td>1.560</td><td>39.6</td></tr> <tr><td>08</td><td>1.690</td><td>42.9</td></tr> <tr><td>09</td><td>1.810</td><td>46.0</td></tr> <tr><td>10</td><td>1.940</td><td>49.3</td></tr> <tr><td>Omit</td><td>.690</td><td>17.5</td></tr> </tbody> </table>	Height Code	E		In.	mm.	01	.810	20.6	02	.940	23.9	03	1.060	26.9	04	1.190	30.2	05	1.310	33.3	06	1.440	36.6	07	1.560	39.6	08	1.690	42.9	09	1.810	46.0	10	1.940	49.3	Omit	.690	17.5														
		Height Code	E																																																						
			In.			mm.																																																			
		01	.810			20.6																																																			
		02	.940			23.9																																																			
		03	1.060			26.9																																																			
	04	1.190	30.2																																																						
	05	1.310	33.3																																																						
	06	1.440	36.6																																																						
	07	1.560	39.6																																																						
	08	1.690	42.9																																																						
	09	1.810	46.0																																																						
10	1.940	49.3																																																							
Omit	.690	17.5																																																							
ZNU Zinc-Nickel with Black Chromate <i>tactical applications (non-reflective black)</i> Additional shell finishes are listed on page C-9.	B	D	<table border="1"> <thead> <tr> <th rowspan="2">Cable Entry Code</th> <th colspan="2">D</th> <th rowspan="2">Shell Size</th> </tr> <tr> <th>In.</th> <th>mm.</th> </tr> </thead> <tbody> <tr><td>01</td><td>.140</td><td>3.56</td><td>A-M</td></tr> <tr><td>02</td><td>.290</td><td>7.37</td><td>B-M</td></tr> <tr><td>03</td><td>.440</td><td>11.18</td><td>C-M</td></tr> <tr><td>04</td><td>.540</td><td>13.72</td><td>D-M</td></tr> <tr><td>05</td><td>.690</td><td>17.53</td><td>E-M</td></tr> <tr><td>06</td><td>.810</td><td>20.57</td><td>F-M</td></tr> <tr><td>07</td><td>1.000</td><td>25.40</td><td>H-M</td></tr> <tr><td>08</td><td>1.190</td><td>30.23</td><td>H-M</td></tr> <tr><td>09</td><td>1.305</td><td>33.15</td><td>K-M</td></tr> <tr><td>10</td><td>1.420</td><td>36.07</td><td>K-M</td></tr> <tr><td>11</td><td>1.600</td><td>40.64</td><td>K</td></tr> <tr><td>12</td><td>1.500</td><td>38.10</td><td>K and M</td></tr> </tbody> </table>	Cable Entry Code	D		Shell Size	In.	mm.	01	.140	3.56	A-M	02	.290	7.37	B-M	03	.440	11.18	C-M	04	.540	13.72	D-M	05	.690	17.53	E-M	06	.810	20.57	F-M	07	1.000	25.40	H-M	08	1.190	30.23	H-M	09	1.305	33.15	K-M	10	1.420	36.07	K-M	11	1.600	40.64	K	12	1.500	38.10	K and M
	Cable Entry Code	D			Shell Size																																																				
		In.		mm.																																																					
	01	.140		3.56	A-M																																																				
	02	.290		7.37	B-M																																																				
	03	.440		11.18	C-M																																																				
04	.540	13.72	D-M																																																						
05	.690	17.53	E-M																																																						
06	.810	20.57	F-M																																																						
07	1.000	25.40	H-M																																																						
08	1.190	30.23	H-M																																																						
09	1.305	33.15	K-M																																																						
10	1.420	36.07	K-M																																																						
11	1.600	40.64	K																																																						
12	1.500	38.10	K and M																																																						
C	D	E																																																							
F	G	H																																																							
J	K	L																																																							
M																																																									

* For Top Entry Style T, shortest height code of E = .69" is limited to shell & entry size combinations A01, B02, C03, D04, E05, F06, G06, H08, J08, K11, L10 & M12 to ensure adequate wire clearance. Contact factory for other combinations. For Side Entry Style S, shortest height code E is acceptable for all shell & entry size combinations except consideration for 12AWG wire bend radius.

Dimensions in Inches (millimeters) are subject to change without notice.





799-015
Low Profile EMI Backshell
for 790-024 and 790-025 Cable Connectors
How To Order

799-015 Low Profile EMI Backshell

STYLE T - TOP ENTRY

STYLE S - SIDE ENTRY

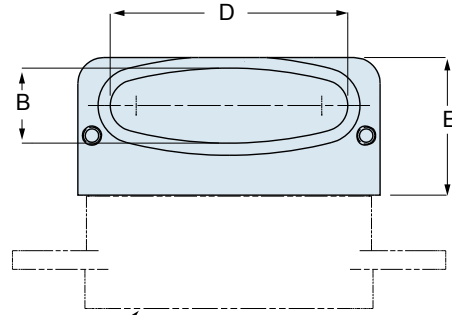
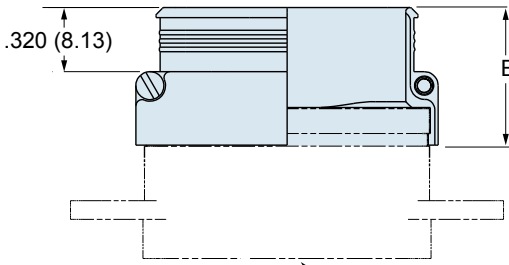
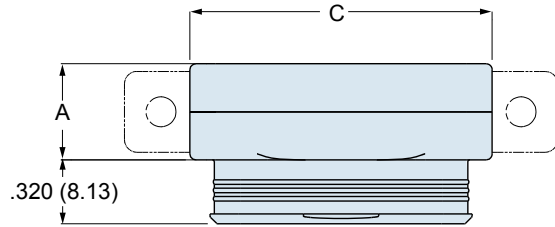
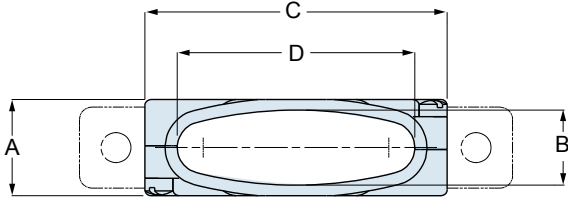

CONNECTOR SHOWN FOR REFERENCE - NOT SUPPLIED

799-015 DIMENSIONS

Shell Size	A Max.		B		C Max.		Available Entries
	In.	mm.	In.	mm.	In.	mm.	
A	.385	9.78	.270	6.86	.485	12.32	01
B	.385	9.78	.270	6.86	.635	16.13	01 thru 02
C	.385	9.78	.270	6.86	.785	19.94	01 thru 03
D	.385	9.78	.270	6.86	.885	22.48	01 thru 04
E	.385	9.78	.270	6.86	1.035	26.29	01 thru 05
F	.385	9.78	.270	6.86	1.185	30.10	01 thru 06
G	.465	11.81	.350	8.89	1.145	29.08	01 thru 06
H	.495	12.57	.380	9.65	1.525	38.74	01 thru 08
J	.385	9.78	.270	6.86	1.545	39.24	01 thru 08
K	.385	9.78	.270	6.86	1.945	49.40	01 thru 11
L	.495	12.57	.380	9.65	1.765	44.83	01 thru 10
M	.555		.440		1.830		01 thru 10, 12

ENTRY SIZE

Entry Size	D		Available Sizes
	In.	mm.	
01	.140	3.56	A Thru L
02	.290	7.37	B thru L
03	.440	11.18	C thru L
04	.540	13.72	D thru L
05	.690	17.53	E thru L
06	.810	20.57	F, H, J, K, L
07	1.000	25.40	H thru L
08	1.190	30.23	H Thru L
09	1.305	33.15	K, L
10	1.420	36.07	K, L
11	1.600	40.64	K
12	1.500	38.10	K and M

HEIGHT CODE

CODE	E	
	In.	mm.
01	.810	20.6
02	.940	23.9
03	1.060	26.9
04	1.190	30.2
05	1.310	33.3
06	1.440	36.6
07	1.560	39.6
08	1.690	42.9
09	1.810	46.0
10	1.940	49.3

Component	Material	Finish
Backshell	Aluminum Alloy	See table below
Hardware	Stainless Steel	Passivated

Dimensions in Inches (millimeters) are subject to change without notice.

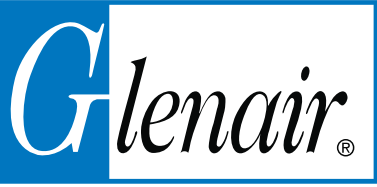

799-011
Standard EMI Backshell
 for 790-024 and 790-025 Cable Connectors
 How To Order

799-011 Standard EMI Backshell

STYLE T - TOP ENTRY

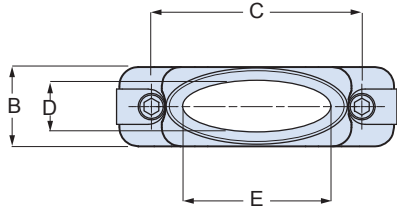

STYLE S - SIDE ENTRY

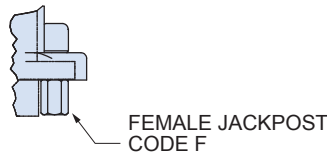
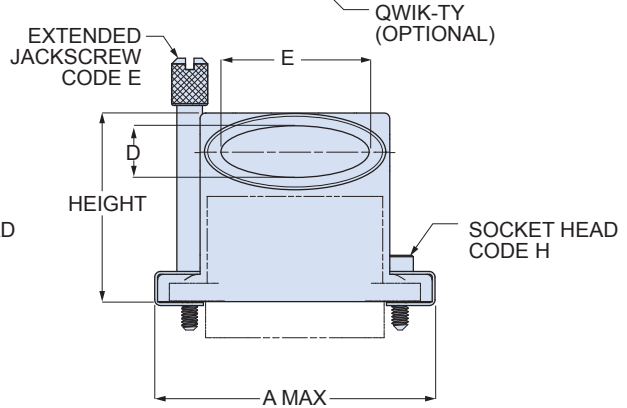
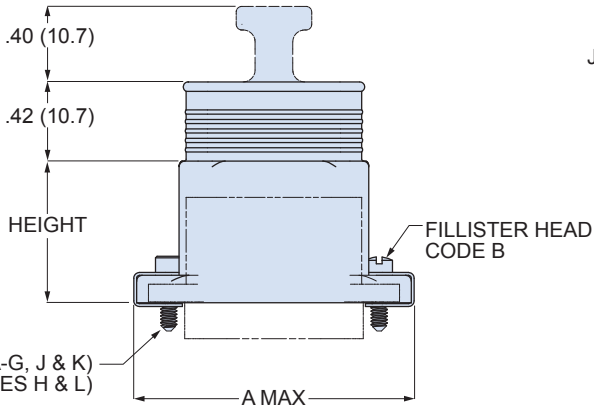
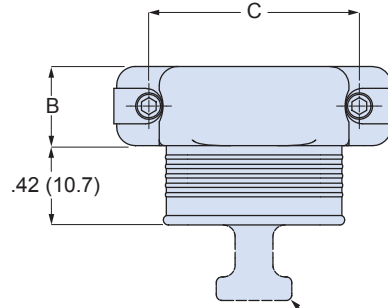

Component	Material	Finish
Backshell	Aluminum Alloy	See table below
Hardware	Stainless Steel	Passivated

799-011 DIMENSIONS

Shell Size	A Max.		B Max.		C		D		Available Entries
	In.	mm.	In.	mm.	In.	mm.	In.	mm.	
A	.935	23.75	.450	11.43	.565	14.35	.300	7.62	01
B	1.085	27.56	.450	11.43	.715	18.16	.300	7.62	01 thru 02
C	1.235	31.37	.450	11.43	.865	21.97	.300	7.62	01 thru 03
D	1.335	33.91	.450	11.43	.965	24.51	.300	7.62	01 thru 04
E	1.485	37.72	.450	11.43	1.115	28.32	.300	7.62	01 thru 05
F	1.635	41.53	.450	11.43	1.265	32.13	.300	7.62	01 thru 06
G	1.585	40.26	.533	13.54	1.215	30.86	.383	9.73	01 thru 06
H	2.320	58.93	.560	14.22	1.800	45.72	.410	10.41	01 thru 08
J	1.990	50.55	.450	11.43	1.615	41.02	.300	7.62	01 thru 08
K	2.385	60.58	.450	11.43	2.015	51.18	.300	7.62	01 thru 11
L	2.556	64.92	.560	14.22	2.036	51.71	.410	10.41	01 thru 10
M	2.720	69.01	.620	15.75	2.200	55.88	.470	11.94	01 thru 10; 12

ENTRY SIZE

Code	E		Available Sizes
	In.	mm.	
01	.300	7.62	A thru M
02	.450	11.43	B thru M
03	.600	15.24	C thru M
04	.700	17.78	D thru M
05	.850	21.59	E thru M
06	.965	24.51	F thru M
07	1.155	29.34	H thru M
08	1.345	34.16	H thru M
09	1.460	37.08	K thru M
10	1.581	40.16	K thru M
11	1.760	44.70	K
12	1.645	41.78	M

Dimensions in Inches (millimeters) are subject to change without notice.

H

799-016
EMI Backshell for Panel Mount Connectors
How To Order



799-016 EMI Backshell
FOR PANEL MOUNT CONNECTORS

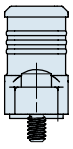
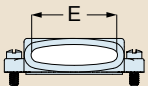
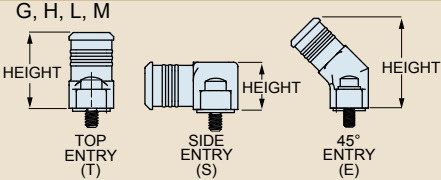
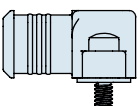
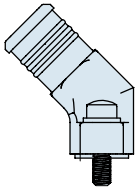

Attach shield braid to panel-mounted connectors with 799-016 EMI adapters. These one-piece backshells attach to connector with stainless steel screws. These adapters feature an interlocking tongue that fits inside the connector for improved EMI shielding. Terminate shields with **BAND-IT™** stainless steel straps. Elliptical cable entry provides room for large wire bundles. These machined T6061 aluminum backshells are supplied with two mounting screws. These adapters fit 790-026 receptacles and 790-027 plugs.

How To Order																																																																																																																																																
Sample Part Number																																																																																																																																																
799-016T	M	F	04	N	09																																																																																																																																											
Part Number	Shell Finish	Shell Size	Cable Entry Size	Band Option	Height Code																																																																																																																																											
 799-016T Top Entry	M Electroless Nickel <i>general purpose applications</i>	A B C	 E	N No Band Supplied	 G, H, L, M HEIGHT TOP ENTRY (T) SIDE ENTRY (S) 45° ENTRY (E)																																																																																																																																											
 799-016S Side Entry	MT Nickel-PTFE <i>1000 Hour Grey™ maximum corrosion protection and durability (non-reflective grey)</i>	D E F G H	<table border="1"> <thead> <tr> <th>Cable Entry Code</th> <th>E (In.)</th> <th>Shell Size</th> </tr> </thead> <tbody> <tr><td>01</td><td>.255</td><td>A-M</td></tr> <tr><td>02</td><td>.405</td><td>B-M</td></tr> <tr><td>03</td><td>.555</td><td>C-M</td></tr> <tr><td>04</td><td>.655</td><td>D-M</td></tr> <tr><td>05</td><td>.805</td><td>E-M</td></tr> <tr><td>06</td><td>.920</td><td>F-M</td></tr> <tr><td>07</td><td>1.110</td><td>H-M</td></tr> <tr><td>08</td><td>1.300</td><td>H-M</td></tr> <tr><td>09</td><td>1.415</td><td>K-M</td></tr> <tr><td>10</td><td>1.535</td><td>K-M</td></tr> <tr><td>11</td><td>1.705</td><td>K</td></tr> <tr><td>12</td><td>1.600</td><td>K and M</td></tr> </tbody> </table>	Cable Entry Code	E (In.)	Shell Size	01	.255	A-M	02	.405	B-M	03	.555	C-M	04	.655	D-M	05	.805	E-M	06	.920	F-M	07	1.110	H-M	08	1.300	H-M	09	1.415	K-M	10	1.535	K-M	11	1.705	K	12	1.600	K and M	M BAND-IT™ Micro-Band Included. .125 (3.18) Wide.	<table border="1"> <thead> <tr> <th colspan="5">Entry Style Range</th> </tr> <tr> <th>Height Code</th> <th>Length (In.)</th> <th>Top Entry (T)</th> <th>Side Entry (S)</th> <th>45° Entry (E)</th> </tr> </thead> <tbody> <tr><td>05</td><td>.313</td><td>—</td><td>A-F, J, K</td><td>—</td></tr> <tr><td>06</td><td>.375</td><td>—</td><td>A-F, J, K</td><td>—</td></tr> <tr><td>07</td><td>.438</td><td>—</td><td>A-L</td><td>—</td></tr> <tr><td>08</td><td>.500</td><td>—</td><td>A-M</td><td>—</td></tr> <tr><td>09</td><td>.563</td><td>A-F, J, K</td><td>A-M</td><td>—</td></tr> <tr><td>10</td><td>.625</td><td>A-G, H, L</td><td>A-M</td><td>—</td></tr> <tr><td>11</td><td>.688</td><td>A-M</td><td>A-M</td><td>A-F, J, K</td></tr> <tr><td>12</td><td>.750</td><td>A-M</td><td>A-M</td><td>A-G, J, K</td></tr> <tr><td>13</td><td>.813</td><td>A-M</td><td>—</td><td>A-L</td></tr> <tr><td>14</td><td>.875</td><td>A-M</td><td>—</td><td>A-M</td></tr> <tr><td>15</td><td>.938</td><td>A-M</td><td>—</td><td>A-M</td></tr> <tr><td>16</td><td>1.000</td><td>A-M</td><td>—</td><td>A-M</td></tr> <tr><td>17</td><td>1.063</td><td>A-M</td><td>—</td><td>A-M</td></tr> <tr><td>18</td><td>1.125</td><td>A-M</td><td>—</td><td>G, H, L, M</td></tr> <tr><td>19</td><td>1.188</td><td>G, H, L, M</td><td>—</td><td>G, H, L, M</td></tr> <tr><td>20</td><td>1.250</td><td>G, H, L, M</td><td>—</td><td>G, H, L, M</td></tr> <tr><td>21</td><td>1.313</td><td>G, H, L, M</td><td>—</td><td>G, H, L, M</td></tr> <tr><td>22</td><td>1.375</td><td>G, H, L, M</td><td>—</td><td>—</td></tr> </tbody> </table>	Entry Style Range					Height Code	Length (In.)	Top Entry (T)	Side Entry (S)	45° Entry (E)	05	.313	—	A-F, J, K	—	06	.375	—	A-F, J, K	—	07	.438	—	A-L	—	08	.500	—	A-M	—	09	.563	A-F, J, K	A-M	—	10	.625	A-G, H, L	A-M	—	11	.688	A-M	A-M	A-F, J, K	12	.750	A-M	A-M	A-G, J, K	13	.813	A-M	—	A-L	14	.875	A-M	—	A-M	15	.938	A-M	—	A-M	16	1.000	A-M	—	A-M	17	1.063	A-M	—	A-M	18	1.125	A-M	—	G, H, L, M	19	1.188	G, H, L, M	—	G, H, L, M	20	1.250	G, H, L, M	—	G, H, L, M	21	1.313	G, H, L, M	—	G, H, L, M	22	1.375	G, H, L, M	—	—
Cable Entry Code	E (In.)	Shell Size																																																																																																																																														
01	.255	A-M																																																																																																																																														
02	.405	B-M																																																																																																																																														
03	.555	C-M																																																																																																																																														
04	.655	D-M																																																																																																																																														
05	.805	E-M																																																																																																																																														
06	.920	F-M																																																																																																																																														
07	1.110	H-M																																																																																																																																														
08	1.300	H-M																																																																																																																																														
09	1.415	K-M																																																																																																																																														
10	1.535	K-M																																																																																																																																														
11	1.705	K																																																																																																																																														
12	1.600	K and M																																																																																																																																														
Entry Style Range																																																																																																																																																
Height Code	Length (In.)	Top Entry (T)	Side Entry (S)	45° Entry (E)																																																																																																																																												
05	.313	—	A-F, J, K	—																																																																																																																																												
06	.375	—	A-F, J, K	—																																																																																																																																												
07	.438	—	A-L	—																																																																																																																																												
08	.500	—	A-M	—																																																																																																																																												
09	.563	A-F, J, K	A-M	—																																																																																																																																												
10	.625	A-G, H, L	A-M	—																																																																																																																																												
11	.688	A-M	A-M	A-F, J, K																																																																																																																																												
12	.750	A-M	A-M	A-G, J, K																																																																																																																																												
13	.813	A-M	—	A-L																																																																																																																																												
14	.875	A-M	—	A-M																																																																																																																																												
15	.938	A-M	—	A-M																																																																																																																																												
16	1.000	A-M	—	A-M																																																																																																																																												
17	1.063	A-M	—	A-M																																																																																																																																												
18	1.125	A-M	—	G, H, L, M																																																																																																																																												
19	1.188	G, H, L, M	—	G, H, L, M																																																																																																																																												
20	1.250	G, H, L, M	—	G, H, L, M																																																																																																																																												
21	1.313	G, H, L, M	—	G, H, L, M																																																																																																																																												
22	1.375	G, H, L, M	—	—																																																																																																																																												
 799-016E 45° Entry	ZNU Zinc-Nickel with Black Chromate <i>tactical applications (non-reflective black)</i>	K L M																																																																																																																																														
	Additional shell finishes are listed on page C-9.																																																																																																																																															

Dimensions in Inches (millimeters) are subject to change without notice.



799-016
EMI Backshell for Panel Mount Connectors
How To Order

799-016 Standard EMI Backshell

799-016 STYLE T - TOP ENTRY

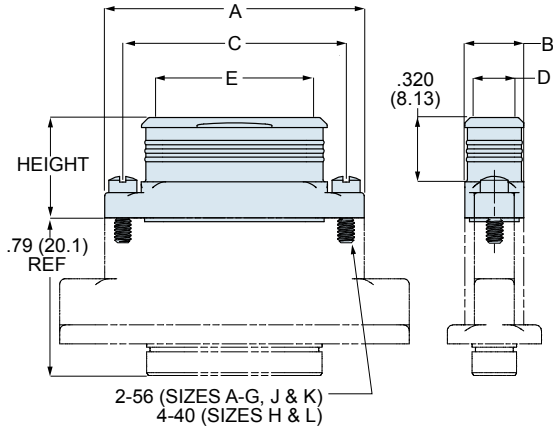

799-016 STYLE E - 45° ENTRY

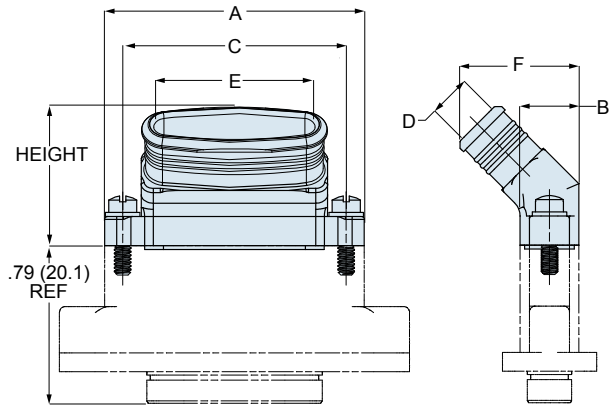

799-016 STYLE S - SIDE ENTRY

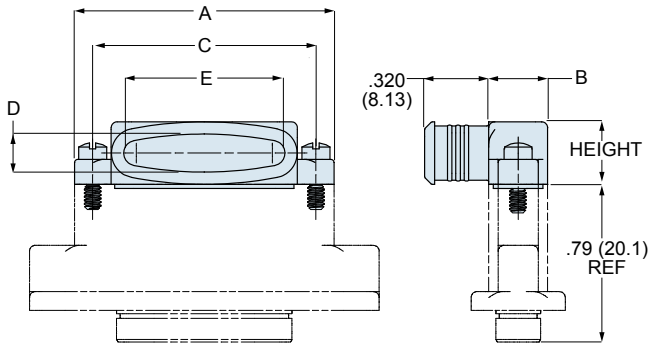

Component	Material	Finish
Backshell	Aluminum Alloy	See table below
Hardware	Stainless Steel	Passivated

799-016 DIMENSIONS

Shell Size	A Max.		B Max.		C		D		F		Max. Entry Size
	In.	mm.	In.	mm.	In.	mm.	In.	mm.	In.	mm.	
A	.760	19.30	.308	7.82	.565	14.35	.190	4.83	.59	15.0	01
B	.910	23.11	.308	7.82	.715	18.16	.190	4.83	.59	15.0	02
C	1.060	26.92	.308	7.82	.865	21.97	.190	4.83	.59	15.0	03
D	1.160	29.46	.308	7.82	.965	24.51	.190	4.83	.59	15.0	04
E	1.310	33.27	.308	7.82	1.115	28.32	.190	4.83	.59	15.0	05
F	1.460	36.83	.308	7.82	1.265	32.13	.190	4.83	.59	15.0	06
G	1.410	35.81	.395	10.03	1.215	30.86	.275	6.99	.68	17.3	06
H	2.045	51.94	.410	10.41	1.800	45.72	.300	7.62	.70	17.8	08
J	1.810	45.97	.308	7.82	1.615	41.02	.190	4.83	.59	15.0	08
K	2.210	56.13	.308	7.82	2.015	51.18	.190	4.83	.59	15.0	11
L	2.281	57.94	.410	10.41	2.036	51.71	.300	7.62	.70	17.8	10
M	2.445	62.10	.470	11.94	2.200	55.88	.360	9.14	.76	19.3	01 thru 10; 12

ENTRY SIZE

Code	E		Available Sizes
	In.	mm.	
01	.255	6.48	A thru M
02	.405	10.29	B thru M
03	.555	14.10	C thru M
04	.655	16.64	D thru M
05	.805	20.45	E thru M
06	.920	23.37	F thru M
07	1.110	28.19	H thru M
08	1.300	33.02	H thru M
09	1.415	35.94	K thru M
10	1.535	38.99	K thru M
11	1.705	43.31	K
12	1.600	40.64	K and M

Dimensions in Inches (millimeters) are subject to change without notice.

799-018 and 799-019 Protective Covers FOR SERIES 79 MICRO-CRIMP CONNECTORS

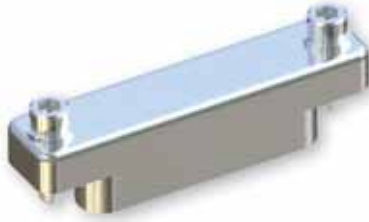





Protect Connectors From Damage – Machined aluminum covers prevent ingress of water and contamination. Plug covers provide metal-to-metal bottoming for EMI protection. Receptacle covers feature conductive fluorosilicone gaskets.

Stainless Steel Fittings and Rings – Choose small diameter eye fittings for panel attachment. Larger rings fit over cable jackets. Split rings can be installed on fully assembled cables.

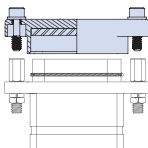
Polyurethane-Coated SST Wire Rope offers high strength, excellent abrasion resistance and good flexibility. Or, choose Teflon® jacket for high temperature exposure.

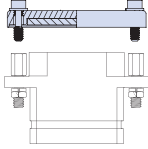
Braided Nylon Rope provides excellent flexibility and good abrasion resistance, and can be ordered with slip knot fittings for easy installation on any size cable.

How To Order						
Sample Part Number						
799-018	E	E	MB	N	6	-04
Part Number	Shell Finish	Shell Size	Jackscrew Option	Lanyard Type	Attachment Length in Inches	Attachment Code
 799-018 Plug Cover	M Electroless Nickel <i>general purpose applications</i>	A B C	MB Slotted Fillister Head Jackscrew	N No Attachment G Nylon Rope H Stainless Steel Rope, Teflon jacket	Omit for Attachment Type N (no attachment) Example "6" equals six inch length	Omit for attachment Types N (No Attachment) and SK (Slip Knot)  Small Ring 01 – .126 (3.20) I.D. 02 – .145 (3.68) I.D. 04 – .188 (4.78) I.D. 06 – .197 (5.00) I.D.
	MT Nickel-PTFE 1000 Hour Grey™ <i>maximum corrosion protection and durability (non-reflective grey)</i>	D E F G H	MH Hex Socket Head Jackscrew	R Stainless Steel Rope, PVC jacket F Stainless Steel Rope, Nylon jacket		
 799-019 Receptacle Cover	ZNU Zinc-Nickel with Black Chromate <i>tactical applications (non-reflective black)</i> Additional shell finishes are listed on page C-9.	J K L M			 Split Ring 50 – .420 (10.67) I.D. 52 – .480 (12.19) I.D. 54 – .635 (16.13) I.D. 56 – .745 (18.92) I.D. 58 – .885 (22.48) I.D. 60 – 1.010 (25.65) I.D. 64 – 1.125 (28.58) I.D. 68 – 1.345 (34.16) I.D.	

Dimensions in Inches (millimeters) are subject to change without notice.



799-018
Protective Plug Covers
How To Order

799-018 Protective Plug Covers

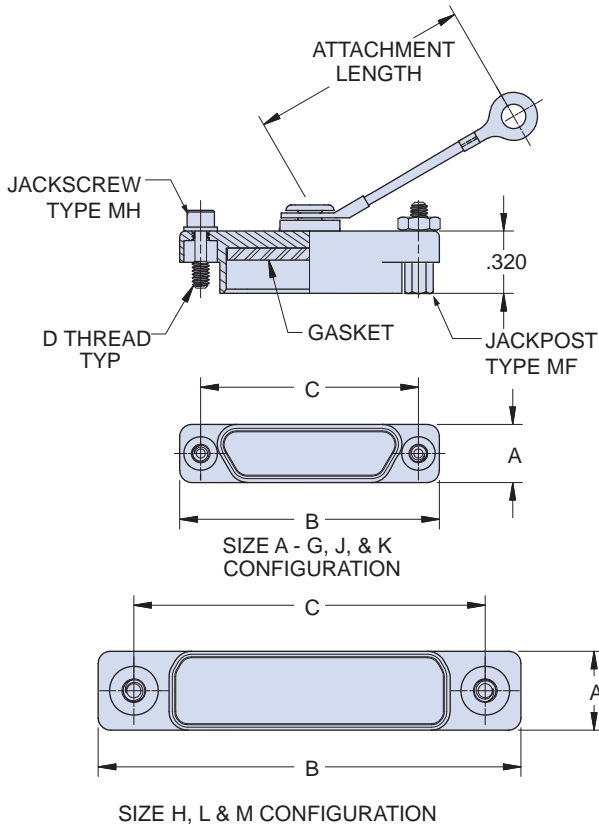

799-018 DIMENSIONS

Shell Size	A Max.		B Max.		C		D Thread
	In.	mm.	In.	mm.	In.	mm.	
A	.308	7.82	.785	19.94	.565	14.35	2-56 UNC
B	.308	7.82	.935	23.75	.715	18.16	2-56 UNC
C	.308	7.82	1.085	27.56	.865	21.97	2-56 UNC
D	.308	7.82	1.185	30.10	.965	24.51	2-56 UNC
E	.308	7.82	1.335	33.91	1.115	28.32	2-56 UNC
F	.308	7.82	1.485	37.72	1.265	32.13	2-56 UNC
G	.395	10.03	1.435	36.45	1.215	30.86	2-56 UNC
H	.410	10.41	2.170	55.12	1.800	45.72	4-40 UNC
J	.308	7.82	1.845	46.86	1.615	41.02	2-56 UNC
K	.308	7.82	2.240	56.90	2.015	51.18	2-56 UNC
L	.410	10.41	2.406	61.11	2.036	51.71	4-40 UNC
M	.470	11.94	2.570	65.28	2.200	55.88	6-32 UNC

Component	Material	Finish
Backshell	Aluminum Alloy	See Ordering Info
Hardware	Stainless Steel	Passivated
Gasket	Conductive Fluorosilicone	None

Lanyard options

	-55° to +100°C., black, very flexible, very good abrasion resistance, good resistance to fuels, .120" (3mm) diameter
Nylon Rope	
	Black polyurethane over stainless steel rope, -55° to +125°C., very flexible, excellent abrasion resistance, excellent resistance to fuels, .080" (2mm) diameter
Polyurethane Coated Wire Rope	
	Translucent FEP jacket over stainless steel, -55° to +200°C., fair flexibility, good abrasion resistance, .100" diameter
Teflon® Jacketed Wire Rope	
	55° to +100°C., black, very flexible, very good abrasion resistance, good resistance to fuels, .120" (3mm) diameter. Length includes .5" (13mm) diameter loop.
Slip Knot (SK) for Attaching Covers to Cable	

Dimensions in Inches (millimeters) are subject to change without notice.

799-019
Protective Receptacle Covers
How To Order



799-019 Protective Receptacle Covers

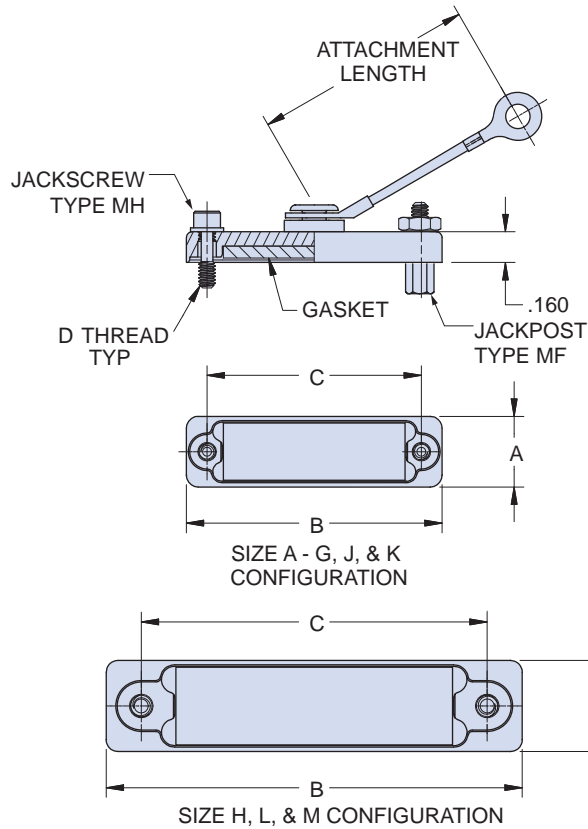

799-019 DIMENSIONS

Shell Size	A Max.		B Max.		C		D Thread
	In.	mm.	In.	mm.	In.	mm.	
A	.385	7.82	.785	19.94	.565	14.35	2-56 UNC
B	.385	7.82	.935	23.75	.715	18.16	2-56 UNC
C	.385	7.82	1.085	27.56	.865	21.97	2-56 UNC
D	.385	7.82	1.185	30.10	.965	24.51	2-56 UNC
E	.385	7.82	1.335	33.91	1.115	28.32	2-56 UNC
F	.385	7.82	1.485	37.72	1.265	32.13	2-56 UNC
G	.470	10.03	1.435	36.45	1.215	30.86	2-56 UNC
H	.490	10.41	2.170	55.12	1.800	45.72	4-40 UNC
J	.385	7.82	1.845	46.86	1.615	41.02	2-56 UNC
K	.385	7.82	2.240	56.90	2.015	51.18	2-56 UNC
L	.490	10.41	2.406	61.11	2.036	51.71	4-40 UNC
M	.550	11.94	2.570	65.28	2.200	55.88	6-32 UNC

Component	Material	Finish
Backshell	Aluminum Alloy	See Ordering Info
Hardware	Stainless Steel	Passivated
Gasket	Conductive Fluorosilicone	None

Lanyard options

	-55° to +100°C., black, very flexible, very good abrasion resistance, good resistance to fuels, .120" (3mm) diameter
Nylon Rope	
	Black polyurethane over stainless steel rope, -55° to +125°C., very flexible, excellent abrasion resistance, excellent resistance to fuels, .080" (2mm) diameter
Polyurethane Coated Wire Rope	
	Translucent FEP jacket over stainless steel, -55° to +200°C., fair flexibility, good abrasion resistance, .100" diameter
Teflon® Jacketed Wire Rope	
	55° to +100°C., black, very flexible, very good abrasion resistance, good resistance to fuels, .120" (3mm) diameter. Length includes .5" (13mm) diameter loop.
Slip Knot (SK) for Attaching Covers to Cable	

Dimensions in Inches (millimeters) are subject to change without notice.

SERIES 79

MICRO-CRIMP

MISSION-CRITICAL CONNECTORS



The Series 79 Micro-Crimp is a High-density, crimp-contact Micro-D, offering advanced EMI shielding and sealing compared to standard D-sub. The connector series is ideally suited for use in mission-critical applications such as satellite payloads. Available in cable, panel-mount and PCB versions, the Micro-Crimp features snap-in size #23 crimp contacts, snap-in Size #12 and #16 power and/or coax contacts in hybrid layouts, easy integration into High-Reliability cable assemblies (no splicing or soldering), and guide pin versions (for blind mating). Series 79 Micro-Crimp is the high-performance, advanced EMC and environmental protection interconnect solution.



Series 79 Micro-Crimp Part Number Index



600-052 B-11	799-016T H-5	809-119 B-5
600-052-1 B-11	799-018 H-7	809-120 B-5
600-057 B-11	799-019 H-7	809-121 B-5
600-057-1 B-11	809-001 B-2	809-124 B-8
600-058 B-11	809-002 B-2	809-125 B-8
600-061 B-11	809-005 B-8	809-126 B-9
600-083 B-11	809-013 B-10	809-127 B-9
600-083-1 B-11	809-015 B-8	809-128 B-8
600-090 B-11	809-042 B-2	809-129 B-9
600-090-1 B-11	809-043 B-2	809-130 B-9
790-024P D-1	809-057 B-8	809-131 B-10
790-025S D-4	809-065A B-2	809-132 B-10
790-026P E-1	809-065C B-2	809-133 B-9
790-027S E-6	809-066A B-2	809-134 B-9
790-028P F-1	809-066C B-2	809-135 B-8
790-029S F-16	809-088 B-10	809-136 B-8
790-036P G-1	809-093 B-4	809-137 B-8
790-037S G-16	809-107-1 B-10	809-138 B-8
790-041P G-6	809-107-2 B-10	830-004 ¹ B-7
790-042S G-21	809-107-3 B-10	830-003 ² B-7
790-043P F-6	809-107-4 B-10	852-015-01 B-6
790-044S F-21	809-110 B-4	852-015-02 B-6
790-049S E-17	809-111 B-4	852-015-03 B-6
790-050P E-11	809-112 B-4	852-016-01 B-6
799-011S H-3	809-113 B-4	852-016-02 B-6
799-011T H-3	809-114 B-5	852-016-03 B-6
799-015S H-1	809-115 B-5	852-017 B-6
799-015T H-1	809-116 B-5	852-018 B-6
799-016E H-5	809-117 B-5	859-006 B-8
799-016S H-5	809-118 B-5	

1. 830-004 supersedes 857-010

2. 830-003 supersedes 857-011

Dimensions in Inches (millimeters) are subject to change without notice.

NEW FROM GLENAIR: SERIES 28

HiPer-D

MIL-DTL-24308 INTERMATEABLE



Bringing 21st Century Technology to the World's Most Popular Connector Interface

The Extreme Duty D-Sub Connector

Meet the Series 28 HiPer-D. Intermateable and intermountable with standard M24308 type D-Subs, the HiPer-D meets the need for improved performance in hostile environments. Unlike standard M24308 connectors with stamped steel shells, the HiPer-D is machined from aluminum or stainless steel. The dielectric inserts are made with thermoset epoxy for unbeatable resistance to chemicals and are capable of 200°C continuous operating temperature. Aerospace grade fluorosilicone grommets and face seals provide watertight sealing. Integrated grounding fingers provide advanced electromagnetic compatibility. Best of all, the HiPer-D is available in every standard and high-density M24308 layout and is stocked for immediate same-day shipment.





SERIES 28 HiPer-D

The Advanced D-Sub Connector for Reliable Performance in Hostile Environments

Product Features

- Environmental, crimp removable rectangular connector
- Advanced temperature, vibration and EMC/electrical performance
- M24308/D-Sub intermatable
- Fits panel and pcb footprint of M24308/D-Sub products
- Available in all 11 "standard" insert arrangements
- Standard Density (#20) and High Density (#22D)
- EMI Spring
- High Temperature Thermoset Epoxy Insulators
- Watertight Sealing
- Rugged Machined One-Piece Shell

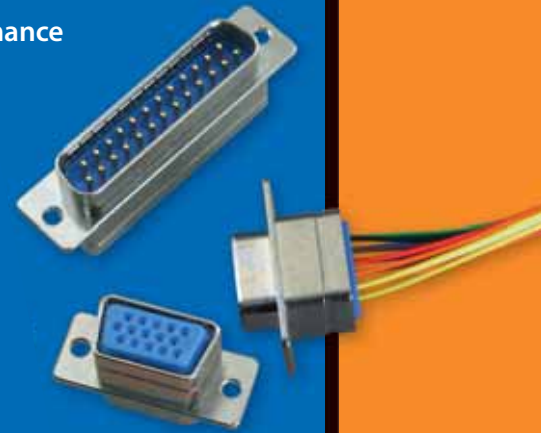

Available configurations

- Crimp Termination for Attaching Wire or Cable: Standard Cable, Rear Panel Mount and Float Mount
- Printed Circuit Board Termination for Rear Panel Mounting: Straight and Right Angle
- Free-Standing Printed Circuit Board Termination: Straight and Right Angle

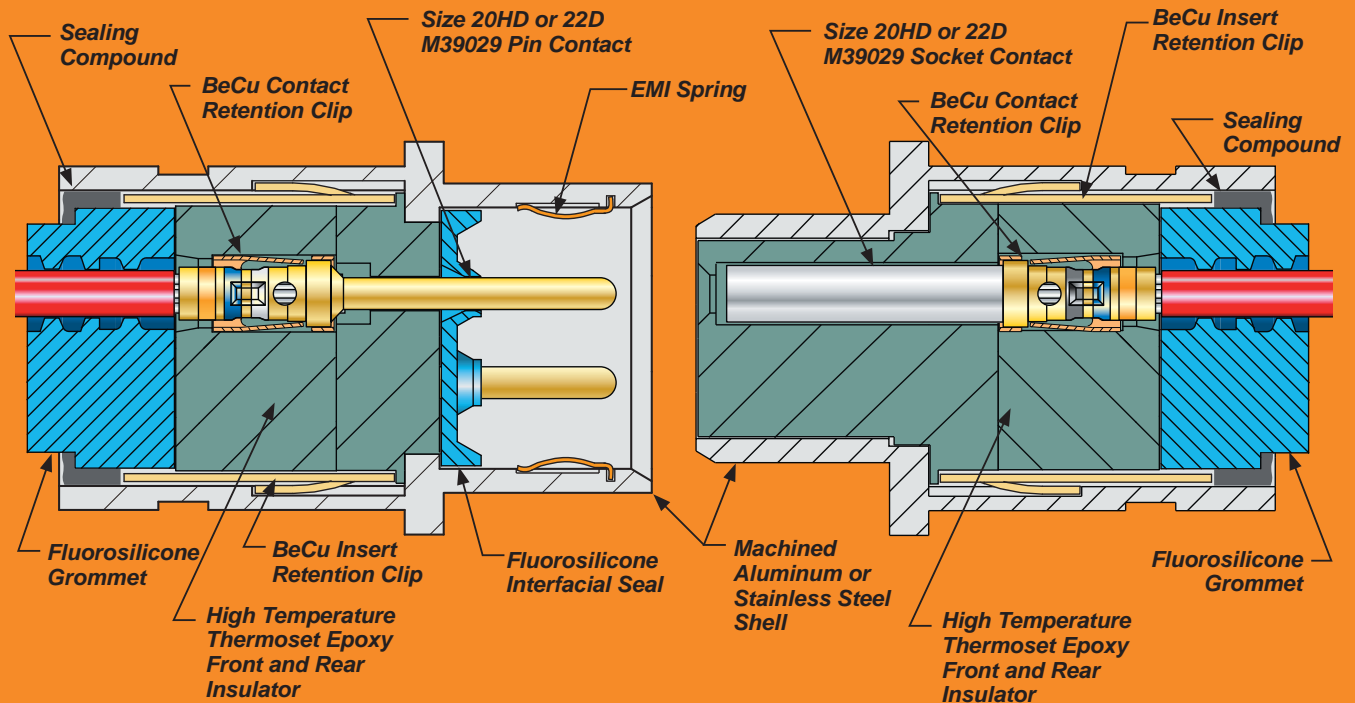

Consult factory for complete ordering information



SERIES 28 HiPer-D

Connector Selection Guide

Connectors with Pin Contacts

Crimp Termination For Attaching Wire or Cable

Standard Cable

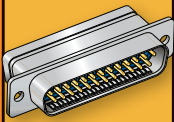

280-018P

Rear Panel Mount



280-020P

Float Mount



280-030P

Printed Circuit Board For Rear Panel Mounting

Straight PCB

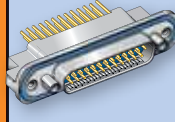

280-022P

Right Angle PCB

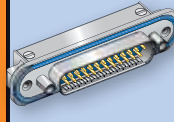

280-024P

Printed Circuit Board Free-Standing

Straight PCB

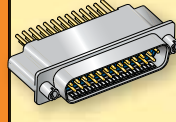

280-026P

Right Angle PCB

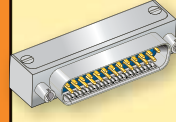

280-028P

Connectors with Socket Contacts

Crimp Termination For Attaching Wire or Cable

Standard Cable

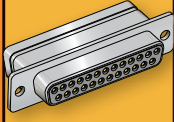

280-019S

Rear Panel Mount



280-021S

Float Mount

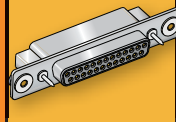

280-031S

Printed Circuit Board For Rear Panel Mounting

Straight PCB

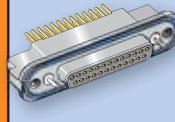

280-023S

Right Angle PCB

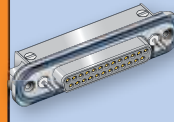

280-025S

Printed Circuit Board Free-Standing

Straight PCB

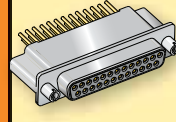

280-027S

Right Angle PCB

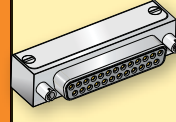

280-029S

Consult factory for complete ordering information



The world's broadest selection of interconnect products—in stock and ready for immediate same-day shipment

Glenair's World of Interconnect Solutions

A complete overview of Glenair's innovative range of interconnect products and services, including Military Standard and commercial equivalent connectors, fiber optic solutions and accessories.



Micro-D Twistpin Connectors and Accessories

Glenair offers both Military Standard 83513 Micro-D connectors as well as COTS selections, backshells, mounting hardware and more. Our TwistPin contact provides superior performance.



EMI/EMP Filter Connectors

MIL-DTL-38999 type EMI/EMP filter connectors, as well as other Military Standard and commercial electromagnetic shielding technologies. Also includes Glenair Series 80 "Mighty Mouse" filter products.

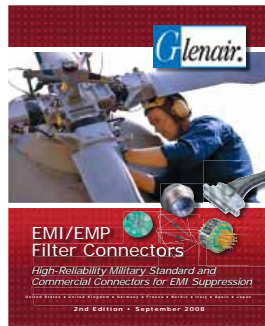

Fiber Optic Interconnect Solutions

Tactical fiber optic connectors, cables, and termini for airframe, shipboard, and military ground vehicles. Catalog features Glenair's innovative high-density (GHD) connector system for reduced size and weight applications.



Available now: Glenair's Interconnect Product Guide CD, featuring our entire library of Glenair catalogs and data sheets.



In addition to over a dozen product line catalogs, the CD includes a powerful part number development program that takes all the pain and confusion out of ordering interconnect components. An easy-to-use inventory search program provides ready access to 60,000 MIL-STD and commercial part numbers.

Series 89 Nano Miniature Connectors

MIL-DTL-32139 qualified connectors for mission-critical board to wire applications. The world's highest performing and most complete .025 inch contact density connector offering. Hundreds of part numbers in stock.



Series 28 HiPer-D Connectors

Fully intermateable and intermountable with standard MIL-DTL-24308 connectors, the Series 28 HiPer-D offers advanced electrical, mechanical and environmental performance for truly mission-critical applications.



Series 80 "Mighty Mouse" Connectors and Cables

Glenair's revolutionary connector series that reduces interconnect system size and weight by 50% compared to standard MIL-DTL-38999 connectors. Now used on hundreds of mission-critical military and commercial applications.

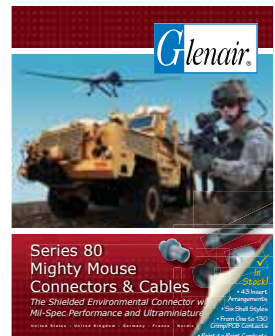

Visit us at www.glenair.com and use the literature order form for immediate catalog fulfillment



A World of Interconnect Solutions

Glenair, Inc.

1211 Air Way • Glendale, California • 91201-2497
Telephone: 818-247-6000 • Fax: 818-500-9912 • sales@glenair.com
www.glenair.com

**Glenair Power
Products Group**
860 N. Main Street Extension
Wallingford, CT
06492

Telephone:
203-741-1115
Facsimile:
203-741-0053
sales@glenair.com

Glenair UK Ltd
40 Lower Oakham Way
Oakham Business Park
P.O. Box 37, Mansfield
Notts, NG18 5BY England

Telephone:
+44-1623-638100
Facsimile:
+44-1623-638111
sales@glenair.co.uk

Glenair Microway Systems
7000 North Lawndale Avenue
Lincolnwood, IL
60712

Telephone:
847-679-8833
Facsimile:
847-679-8849

Glenair Nordic AB
Gustav III : S Boulevard 46
S - 169 27 Solna
Sweden

Telephone:
+46-8-50550000
Facsimile:
+46-8-50550001
sales@glenair.se

Glenair Electric GmbH
Siemensstrasse 9
D-61449 Steinbach
Germany

Telephone:
+49-6171-5905-0
Facsimile:
+49-6171-5905-90
germany@glenair.com

Glenair Iberica
C/ La Vega, 16
45612 Velada
Spain

Telephone:
+ 34-925-89-29-88
Facsimile:
+ 34-925-89-29-87
sales@glenair.es

Glenair Italia S.p.A.
Via Cà dell'Orbo Nord, 22
40055 Villanova di Castenaso
Bologna, Italy

Telephone:
+39-051-780098
Facsimile:
+39-051-782259
info@glenair.it

Glenair France SARL
7, Avenue Parmentier
Immeuble Central Parc #2
31200 Toulouse
France

Telephone:
+33-5-34-40-97-40
Facsimile:
+33-5-61-47-86-10
sales@glenair.fr

