

ULTRAMINIATURE CIRCULAR

SERIES 806 MIGHTY MOUSE MIL-AERO CONNECTORS

**Next-Generation High-Density Connector Series for Demanding
Aerospace, Defense and other Harsh-Application Environments**

FIRST EDITION · APRIL 2017



Series 806 Mighty Mouse Mil-Aero Connectors

Advanced electrical, mechanical and environmental performance *plus reduced size and weight* compared to D38999

Series 806 offers significant size and weight savings while meeting key performance benchmarks for a broad range of applications such as commercial and military aerospace, industrial robotics, transportation systems and more. Designed for general use in harsh vibration, shock and environmental settings—as well as high-altitude, unpressurized aircraft zones with aggressive voltage ratings and altitude immersion standards—the Series 806 Mil-Aero features numerous mechanical design innovations including durable mechanical insert retention, radial seals and triple-ripple grommet seals. Its reduced thread pitch and re-engineered ratchet prevent decoupling problems, particularly in small shell sizes, solving one of the major problems of shell size 9 and 11 MIL-DTL-38999 Series III connectors.

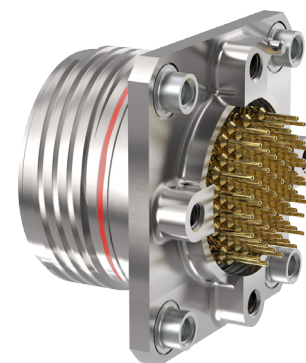

- Next-generation small form factor aerospace-grade circular connector
- Designed for general use in harsh application environments such as aircraft, industrial robotics and more
- Upgraded environmental, electrical and mechanical performance
- Integrated anti-decoupling technology
- Higher density 20HD and 22HD contact arrangements
- Glass hermetic, lightweight aluminum hermetic, and filtered versions
- +200° C temperature rating

SAVE SIZE AND WEIGHT WITH SERIES 806 CONNECTORS

Series 806 Mil-Aero
Smallest Size
.500 In. Mating Threads
3 #20 Contacts or 7 #22
contacts



MIL-DTL-38999
Smallest Size
.625 In. Mating Threads
3 #20 Contacts or 6 #22
contacts



MIGHTY MOUSE MIL-AERO GENERAL INFORMATION AND REFERENCE



Introduction and Product Features
Page 2

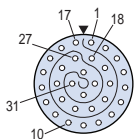

Contact Arrangements
Page 5

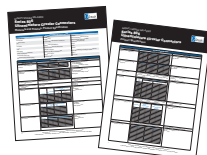

Performance Specifications
Page 6



Space-Grade Information
Page 9

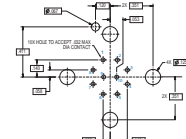

Printed Circuit Board Layouts
Page 70

SERIES 806 MIGHTY MOUSE MIL-AERO CONNECTORS



Plugs
806-012
Page 10



Square Flange Receptacles
806-013
Page 12



Line Receptacles
806-019
Page 14



Jam Nut Receptacles
806-020
Page 16



Jam Nut PCB Receptacles
806-021
Page 18



Square Flange PCB Receptacles
806-022
Page 20



Glass Hermetic Receptacles
806-025
Page 22



Glass Hermetic PCB Receptacles
806-026
Page 25



Lightweight Hermetic PCB Receptacles
806-028
Page 28



Filtered Receptacles
240-806
Page 30



Filtered PCB Receptacles
240-806-21
Page 32

SERIES 806 MIGHTY MOUSE MIL-AERO ACCESSORIES



Contacts
Page 34



Crimp Tools, Ins/Ext Tools
Page 37



Filler Plugs
Page 38



Band-Master ATS®
Page 38



Panel O-rings
Page 38

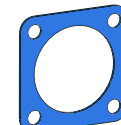

Panel Gaskets
Page 39



Connector Holding Tools
Page 39



Nut Plates
Page 40



Protective Covers
Page 41



Stowage Receptacles
Page 44



Shrink Boots
Page 45



Backshell Selection Guide
Page 48



About The Series 806

The Mighty Mouse Series 806 Mil-Aero is an aerospace-grade ultraminiature circular connector with triple-start threaded coupling. The 806 connector is smaller and lighter than traditional aerospace connectors. Featuring size 20HD and 22HD contacts, the Series 806 offers up to twice the number of contacts with no reduction in performance. Independent laboratory testing has demonstrated that the Series 806 meets the requirements of MIL-DTL-38999 Series III.

But there is more to the 806 than size and weight reduction. This new high-performance connector has many innovative features that meet the most aggressive requirements of the military/aerospace industry. One such feature is better resistance to vibration-induced decoupling. This is accomplished by re-engineering the ratchet mechanism and introducing a shallower mating thread ramp angle.

Glenair pioneered integral banding platforms to allow direct attachment of cable shields, boots and overmolds. This innovation continues with the 806, Glenair's first connector to exclusively use the ultralightweight Nano-Band for maximum size and weight reduction.

Another enhancement is a "top hat" insulator with raised bosses for foolproof alignment of insulator cavities and retention clips as well as higher voltage ratings.

The 806 series connector features an O-ring radial interface sealing design instead of a flat gasket. This allows for easier metal-to-metal coupling, improved sealing, and better EMI performance. The MIL-DTL-38999 Series III and other legacy aerospace circular connectors have a flat gasket inside the receptacle shell. This peripheral seal must be compressed sufficiently to allow full metal-to-metal connector bottoming. In certain tolerance conditions this seal can make it difficult to fully mate the connectors "without the use of tools" as is required by MIL-DTL-38999.

Save Size and Weight with Series 806 Connectors
 Mighty Mouse Mil-Aero Is The Next Generation Higher Density Connector for Demanding Aerospace and Defense Applications



MIL-DTL-38999 Series 806

Series 806 plug with 19 #22 contacts compared to MIL-DTL-38999 Series III with 6 #22 contacts. More than 3X the number of contacts, yet only .020 inches larger diameter.

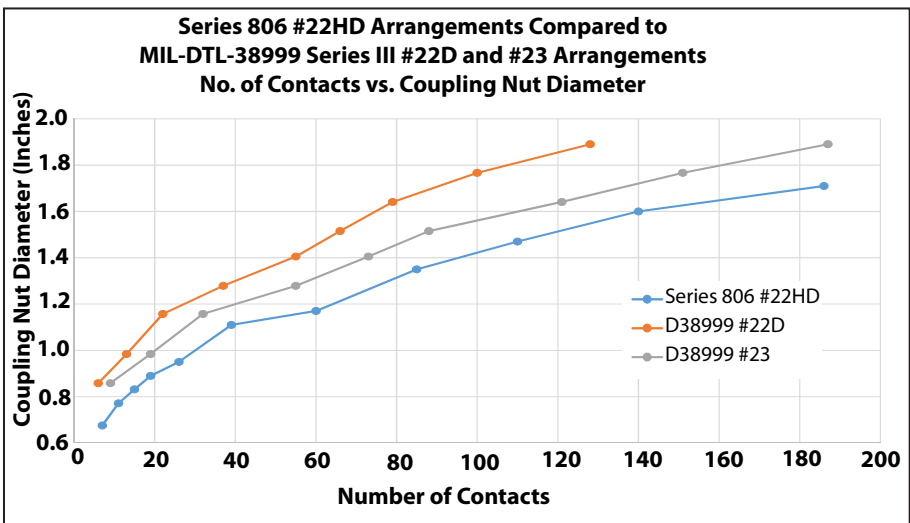
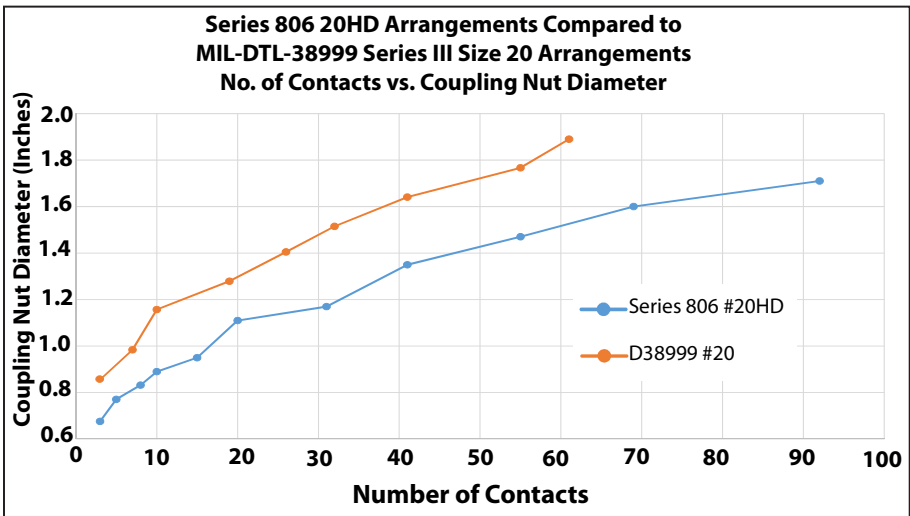



KEY FEATURES

- Next-generation high performance ultraminiature aerospace connector
- Reduced pitch triple-start modified anti-decoupling stub ACME thread
- Higher density 20HD and 22HD contact arrangements
- +200° C operating temperature
- High strength aluminum alloy plug barrel
- “Triple ripple” wire sealing grommet (75,000 ft. rated)
- Snap in, rear release crimp contacts
- Metal contact retention clips
- Integral Nano-Band shield termination platform
- EMI shielding effectiveness per MIL-DTL-38999M para. 4.5.28 (65 dB min. leakage attenuation @ 10GHz)
- 10,000 amp indirect lightning strike
- 300g. shock
- MIL-S-901 Grade A high impact shock
- Aluminum and stainless steel versions
- Environmental crimp contact, glass-to-metal seal PC tail and solder cup hermetics, and EMI filter versions
- RoHS compliant nickel, nickel-PTFE, black zinc and stainless steel plus mil-grade cadmium finish options
- Printed circuit board versions with threaded flange

Plug Connector

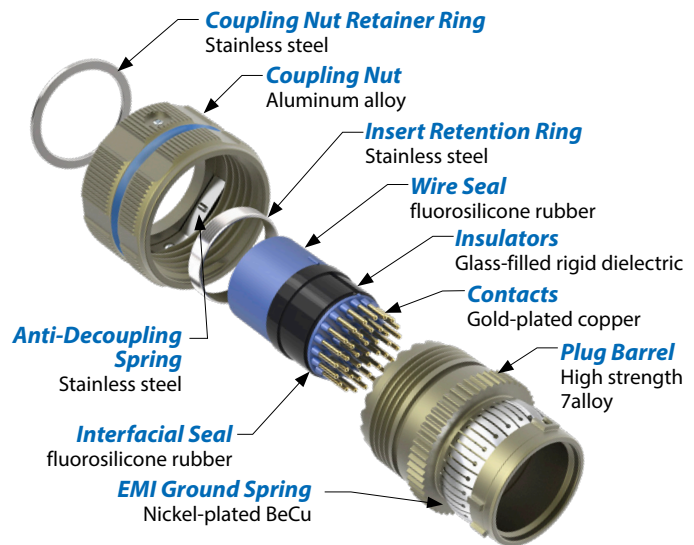

Receptacle Connector

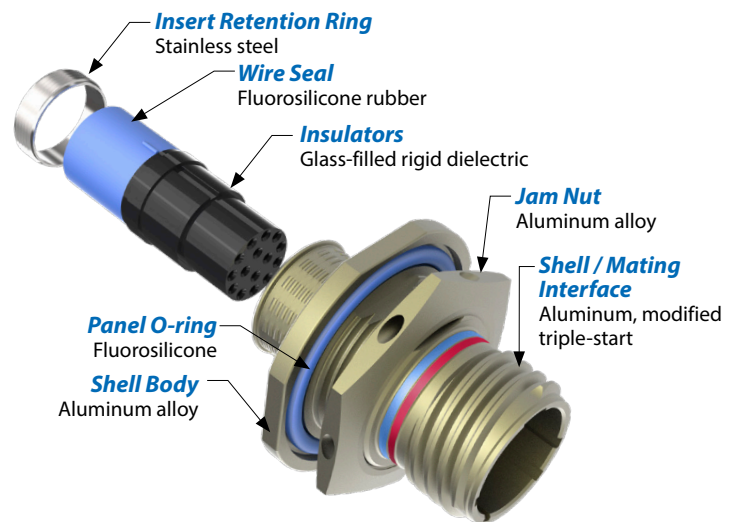

AVAILABLE LIGHTWEIGHT ALUMINUM “CODE RED” HERMETICS

CODE RED is a lightweight encapsulant sealing and application process with 50% package-weight savings compared to glass-to-metal seal Kovar/stainless steel solutions. Non-outgassing CODE RED (IAW NASA/ESA) provides durable hermetic sealing with better than 1×10^{-7} leak rate performance. Gold-plated copper contacts deliver outstanding low-resistance current carrying capacity. See 806-028 page 27.



SERIES 806 MIGHTY MOUSE MIL-AERO FEATURES

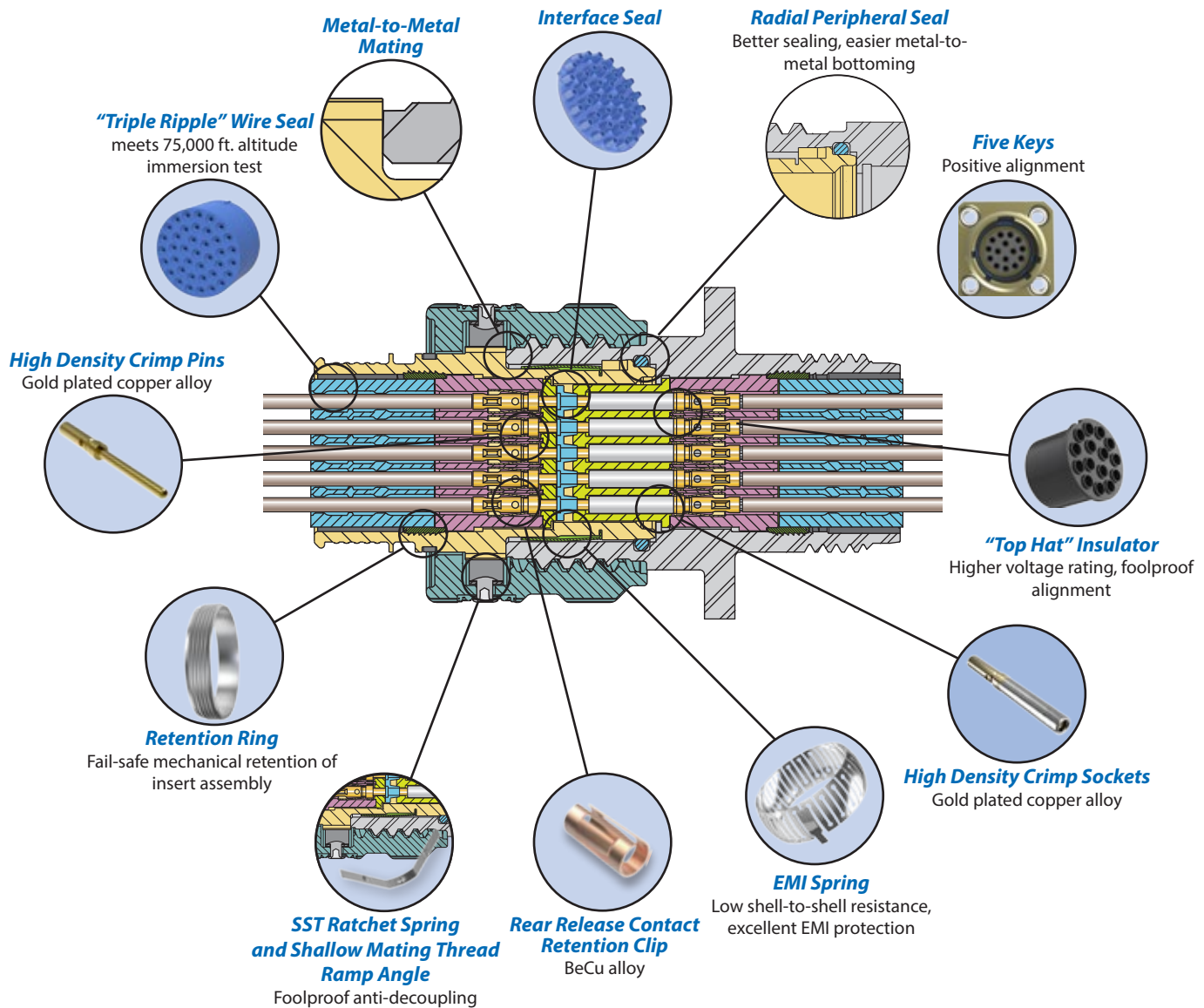

Series 806 Mighty Mouse, with its high-density size #20HD and #22HD contact arrangements, is designed for universal mil-aero use. The many special design features shown above allow this ultraminiature connector to meet and even exceed MIL-DTL-38999 performance even in high-altitude, unpressurized zones. Other Mighty Mouse Series connectors, such as the 801 and 805 with their size #23 contact layouts, are optimized for size and weight reduction in land, sea and pressurized-zone aircraft applications.



Series 806 Arrangements with #20HD Contacts (1800 Vac, 7.5 A)								
Mating face of pin connector. Socket numbering is reversed. Symbol ▼ indicates master key location.								
	Arrangement No. 8-3	Arrangement No. 9-5	Arrangement No. 10-8	Arrangement No. 11-10	Arrangement No. 12-15	Arrangement No. 14-20	Arrangement No. 16-31	
No. of Contacts	3	5	8	10	15	20	31	
Mating face of pin connector. Socket numbering is reversed. Symbol ▼ indicates master key location.								
	Arrangement No. 18-41	Arrangement No. 20-55	Arrangement No. 22-69	Arrangement No. 24-92				
No. of Contacts	41	55	69	92				
Series 806 Arrangements with #22HD Contacts (1300 Vac, 5 A)								
Mating face of pin connector. Socket numbering is reversed. Symbol ▼ indicates master key location.								
	Arrangement No. 8-4	Arrangement No. 8-7	Arrangement No. 9-11	Arrangement No. 10-15	Arrangement No. 11-19	Arrangement No. 12-26	Arrangement No. 14-39	Arrangement No. 16-60
No. of Contacts	4	7	11	15	19	26	39	60
Mating face of pin connector. Socket numbering is reversed. Symbol ▼ indicates master key location.								
	Arrangement No. 18-85	Arrangement No. 20-110	Arrangement No. 22-140	Arrangement No. 24-186				
No. of Contacts	85	110	140	186				



Standard Materials and Finishes		
DESCRIPTION	MATERIAL	FINISH
Pin Contact	Copper alloy	50 microinches gold over nickel
Socket Contact	Copper alloy, with stainless steel hood	50 microinches gold over nickel Contact hood: passivate
Insulators	High grade rigid dielectric	None
Seals	Fluorosilicone/silicone blend, blue	None
EMI Spring	Beryllium copper	Nickel
Shell, Coupling Nut, Jam Nut	Aluminum alloy or stainless steel	See sales drawing or catalog for finish options
Contact Retention Clip	Beryllium copper	None
Anti-Decoupling Ratchet Spring	Stainless steel	Passivate

Performance Specification				
TEST DESCRIPTION	REQUIREMENT			PROCEDURE
Dielectric withstanding voltage at sea level	Contact Size	Altitude	Voltage	
	20HD	Sea level	1800	
	22HD	Sea level	1300	
Dielectric withstanding voltage at altitude	Contact Size	Altitude	Voltage	
	20HD	50,000 ft	1000	
		70,000 ft	1000	
		100,000 ft	1000	
	22HD	50,000 ft	800	
		70,000 ft	800	
100,000 ft		800		
Insulation resistance at ambient temperature	5000 megohms minimum			MIL-DTL-38999M para. 4.5.11.1 EIA-364-20 Method A 2 mA maximum leakage current Unmated pairs
Insulation resistance at elevated temperature	1000 megohms minimum			MIL-DTL-38999M para. 4.5.11.2 EIA-364-20 Method A 2 mA maximum leakage current Mated pairs
Contact resistance at 25°C, crimp contacts	Wire Size	Test Current Amperes	Maximum Voltage Drop (millivolts)	
			Initial	After Conditioning
	20	7.5	55	66
	22	5	73	88
	24	3	45	54
	26	2	52	63
	28	1.5	54	65
	30	1	60	73
Contact resistance at 200° C, crimp contacts	Wire Size	Test Current Amperes	Maximum Voltage Drop (millivolts)	
			Initial	After Conditioning
	20	7.5	94	
	22	5	125	
	24	3	77	
	26	2	89	
	28	1.5	92	
	30	1	103	
Low level contact resistance, crimp contacts	Wire Size	Maximum Contact Resistance (milliohms)		
		Initial Values	After Conditioning	
	20	9	11	
	22	15	17	
	24	20	23	
	26	31	38	
	28	50	60	
30	75	88		



Performance Specification					
TEST DESCRIPTION	REQUIREMENT			PROCEDURE	
Contact resistance, glass-sealed hermetic connectors	Contact Size, Wire Size	Test Current Amperes	Maximum Millivolt Drop		MIL-DTL-38999M Para. 3.18.2 EIA-364-06
			Initial	After Conditioning	
	20	5	60	75	
	22	3	85	95	
Shell-to-shell conductivity	Finish Code	Shell Matl/Fin	Millivolt Drop (mV)		MIL-DTL-38999M Para. 4.5.25 EIA-364-83
	NF	Al/OD Cad	2.5		
	MT	Al/Ni-PTFE	2.5		
	ME	Al/EN	1.0		
	ZR	Al/Zn-Ni	2.5		
	Z1	SST/pass.	10.0		
Backshell shield braid to shell conductivity	Finish Code	Shell Matl/Fin	Millivolt Drop (mV)		MIL-DTL-38999M Para. 4.5.25.1 EIA-364-83
	NF	Al/OD Cad	5.0		
	MT	Al/Ni-PTFE	5.0		
	ME	Al/EN	3.5		
	ZR	Al/Zn-Ni	5.0		
	Z1	SST/pass.	15.0		
Indirect lightning strike	No evidence of damage which could impair proper functioning. Connectors shall meet shell-to-shell conductivity, DWV and coupling torque.			MIL-DTL-38999M Para. 4.5.47 EIA-364-75 10,000 Amps peak current	
	EMI shielding	Leakage Attenuation, (dB) minimum		MIL-DTL-38999M Para. 4.5.28	
	Freq. MHz	Electroless Nickel Finish	Cadmium, Nickel-PTFE, Zinc-Nickel Finish		
	100	90	90		
	200	88	88		
	300	88	88		
	400	87	87		
	800	85	85		
	1,000	85	85		
	1,500	76	69		
	2,000	70	65		
	3,000	69	61		
	4,000	68	58		
	6,000	66	55		
	10,000	65	50		
Durability	No evidence of damage which could impair proper functioning following 500 cycles of mating and unmating.			MIL-DTL-38999M Para. 4.5.8 EIA-364-09	
Coupling and uncoupling torque	Shell size	Maximum Engagement lbs.-inch.	Minimum Disengagement lbs.-inch.		MIL-DTL-38999M Para. 4.5.7 EIA-364-114
	8	8	2		
	9	8	2		
	10	12	2		
	11	12	2		
	12	12	2		
	14	16	2		
	16	20	3		
	18	24	3		
	20	28	3		
	22	32	5		
	24	36	5		
	Insert retention	100 pounds per square inch, 25 pound minimum force			
External bend moment	Shell size	Pound inches			MIL-DTL-38999M Para. 4.5.16 EIA-364-43
	8	100			
	9	100			
	10	100			
	11	200			
	12	300			
	14	400			
	16	500			
	18	600			
	20	700			
	22	800			
	24	900			



Performance Specification																							
TEST DESCRIPTION	REQUIREMENT	PROCEDURE																					
Contact retention	<table border="1"> <thead> <tr> <th>Contact size</th> <th>Pounds ± 10 percent</th> </tr> </thead> <tbody> <tr> <td>22HD</td> <td>10</td> </tr> <tr> <td>20HD</td> <td>10</td> </tr> </tbody> </table>	Contact size	Pounds ± 10 percent	22HD	10	20HD	10	MIL-DTL-38999M Para. 4.5.20.1 EIA-364-29															
Contact size	Pounds ± 10 percent																						
22HD	10																						
20HD	10																						
Magnetic permeability	2 μ maximum	MIL-DTL-38999M Para. 4.5.48 EIA-364-54																					
Contact engaging /separation force	Contact forces shall meet AS39029 Table 9 requirements	AS39029C Para. 4.7.6 EIA-364-37																					
Temperature cycling (thermal shock)	No evidence of damage detrimental to the function of the connector	MIL-DTL-38999M Para. 4.5.4 EIA-364-32 Mated connectors, -65° C to +200° C																					
Random vibration, elevated temperature, 43g rms	No discontinuities of 1 microsecond or longer No resonance at frequencies less than 300 Hz	MIL-DTL-38999M Para. 4.5.23.2.3 with Figure 24 accessory load EIA-364-28 +200° C																					
Random vibration, ambient temperature, 49g rms	No discontinuities of 1 microsecond or longer	MIL-DTL-38999M Para. 4.5.23.2.4 EIA-364-28 Test Condition V																					
Sine vibration, 60g	No discontinuities of 1 microsecond or longer	MIL-DTL-38999M Para. 4.5.23.2.1 with Figure 24 accessory load 12 hours in each of 3 axes 4 hours at ambient, 4 hours at -55° C, 4 hours at +200° C																					
Mechanical shock, 300g	No discontinuities of 1 microsecond or longer	MIL-DTL-38999M Para. 4.5.24.1 EIA-364-27																					
High impact shock (901)	No discontinuities of 1 microsecond or longer No evidence of damage which could impair proper functioning.	MIL-DTL-38999M Para. 4.5.24.2 MIL-S-901 Grade A																					
Humidity, cyclic	Meet DWV and IR test	MIL-DTL-38999M Para. 4.5.26 EIA-364-31 Method 4 10 cycles, 10 days, 25 – 65° C 80 – 100% RH																					
Ozone exposure	No evidence of damage detrimental to the function of the connector	MIL-DTL-38999M Para. 4.5.29 EIA-364-14																					
Fluid immersion	No damage to plastic, elastomeric and bonding materials detrimental to the function of the connector. Connector shall meet coupling torque and DWV requirements when tested within 3 hours of immersion.	MIL-DTL-38999M Para. 4.5.30 EIA-364-10																					
Altitude immersion	No evidence of moisture on connector interface or contacts. At the end of the third cycle, while still submersed, connectors shall meet dielectric withstanding voltage and 1,000 megohms insulation resistance.	MIL-DTL-38999M Para. 4.5.9 EIA-364-03 75,000 feet																					
Altitude- low temperature	Connectors shall meet insulation resistance requirement while at -65° C and 100,000 ft. Connectors shall meet DWV requirement when returned to ambient conditions.	MIL-DTL-38999M Para. 4.5.21 EIA-364-105 -65° C 100,000 ft.																					
Thermal vacuum outgassing	All nonmetallic materials shall not exceed 1.0% Total Mass Loss and 0.1% Total Volatile Condensable Materials. Applicable only to connectors that have been subjected to optional thermal vacuum outgassing.	MIL-DTL-38999M Para. 4.5.42 ASTM E595																					
Salt Spray (dynamic)	<table border="1"> <thead> <tr> <th>Finish Code</th> <th>Matl/Fin</th> <th>Hours</th> </tr> </thead> <tbody> <tr> <td>NF</td> <td>Al/OD Cad</td> <td>500</td> </tr> <tr> <td>MT</td> <td>Al/Ni-PTFE</td> <td>500</td> </tr> <tr> <td>ME</td> <td>Al/EN</td> <td>96</td> </tr> <tr> <td>ZR</td> <td>Al/Zn-Ni</td> <td>500</td> </tr> <tr> <td>Z1</td> <td>SST/passivate</td> <td>1000</td> </tr> <tr> <td>ZL</td> <td>SST/Ni</td> <td>1000</td> </tr> </tbody> </table>	Finish Code	Matl/Fin	Hours	NF	Al/OD Cad	500	MT	Al/Ni-PTFE	500	ME	Al/EN	96	ZR	Al/Zn-Ni	500	Z1	SST/passivate	1000	ZL	SST/Ni	1000	MIL-DTL-38999M Para. 4.5.13.2 EIA-364-26 500 mating cycles
Finish Code	Matl/Fin	Hours																					
NF	Al/OD Cad	500																					
MT	Al/Ni-PTFE	500																					
ME	Al/EN	96																					
ZR	Al/Zn-Ni	500																					
Z1	SST/passivate	1000																					
ZL	SST/Ni	1000																					

Series 806

Mighty Mouse Mil-Aero Connectors

Space-grade Guidelines for Series 806 Connectors



Series 806 Connectors for Space Flight

The Series 806 is an ideal interconnect choice for space flight equipment. The series 806 features space materials, finishes, and performance specifications that match MIL-DTL-38999 Class G space-grade connectors, except with higher density and lower weight.

Outgassing

Space flight equipment requires low-outgassing components in order to prevent degradation to optics and other sensitive instruments. Series 806 connectors contain nonmetallic materials such as rubber, plastic, adhesives and potting compounds which can give off gasses when subjected to a vacuum or high heat. Unless the connector is specially processed, the TML and CVCM can exceed allowable limits. The space industry has adopted a standardized test procedure, ASTM E595, to evaluate outgassing properties. The MIL-DTL-38999 specification Class G also details specific TVM and CVCM values. In Glenair's 429J process, for example, connectors and connector materials are heated to 175°C at a vacuum of 5×10^{-3} torr for 48 hours. Items under test are then weighed to calculate the Total Mass Loss (TML), which may not exceed 1.0% of the total initial mass. A collector plate is used to determine the Collected Volatile Condensable Material (CVCM), which may not exceed 0.1% of the total original specimen mass. Glenair is able to offer outgassing processes which assure all materials comply with their respective standards.

Note on Connector Material and Finish Options

Some types of metals are prohibited for space flight. "Cadmium, zinc, chemically coated cadmium or zinc, or silver shall not be used as a connector or contact finish" (NASA EEE-INST-002 Instructions for EEE Parts Selection, Screening, Qualification, and Derating). NASA recommends electroless nickel or gold finish on connector shells and gold finish for contacts.

Specifying a Space-grade Series 806 Connector

- 1 Choose a NASA EEE-INST-002 Table 2A screening level.** This table contains three screening levels: **Level 1** for missions requiring the highest reliability and lowest level of risk, **Level 2** for low to moderate risk missions, and **Level 3** missions where enhanced screening and inspection is not invoked.
- 2 Choose outgassing process.** Three options are available: no special processing, 48 hour bakeout, or thermal vacuum outgassing.
- 3 Select the modification code** from the table and add it to the Series 806 part number. Example: 806-012-ME8-7PMA-**186T**.

Modification Codes for Nasa and D38999 Class G Levels					
Screening Level	Screening Type	No Outgassing Processing	48 Hour Oven Bake 175° C 100%	Thermal Vacuum Outgassing 24 Hour 125° C 100%	Mod Code
3	Standard Reliability			●	186M
			●		186T
2	High Reliability	●			429
			●	●	429A
			●		429K
1	Highest Reliability	●			429B
				●	429C
			●		429J

NASA EEE-INST-02, TABLE 2A SCREENING LEVELS			
Inspection	Level 1	Level 2	Level 3
Visual	100%	100%	100%
Mechanical	2	2	
Dielectric Withstanding Voltage	2	2	
Insulation Resistance	2	2	
Contact Engagement & Separation Force	2		
Hermeticity (Sealed Receptacles Only)	100%	100%	100%
Coupling Force	2		

Note: required inspection quantity is shown. Zero acceptance of failures allowed for all quantities inspected.



Features

- Triple-start stub ACME mating thread
- High density #20HD and #22HD arrangements for reduced size and weight
- Aerospace-grade materials, construction
- Snap-in crimp contacts

Specifications

- Operating temperature:
Finishes ME, MT, Z1: -65°C to +200°C
Finishes NF, ZR: -65°C to +175°C
- Wire sizes:
#20HD contacts: 20–24 AWG
#22HD contacts: 22–28 AWG
- Dielectric withstanding voltage
#20HD layouts: 1800 Vac
#22HD layouts: 1300 Vac
- Current rating
#20HD contacts 7.5 A
#22HD contacts 5 A
- Mating durability: 500 cycles
- Mechanical shock: EIA-364-27, 300g.
- Vibration (sine): MIL-DTL-38999M, 60g.
- Vibration (random) EIA-364-28 Condition VI, Letter J, 43.92 Grms, +200°C
- High Impact shock: MIL-S-901 Grade A
- Humidity: EIA-364-31 Method 4
- Salt spray (dynamic): EIA-364-26, 500 hours (96 hours for nickel-plated versions)
- Altitude immersion: EIA-364-03 75,000 feet altitude

Connector Construction

- Shell and coupling nut: aluminum or stainless steel
- Contacts: copper alloy, gold plating
- Wire grommet: fluorosilicone
- Dielectric inserts: high grade rigid dielectric
- Ground spring: copper alloy, nickel plating
- Contact retention clips: copper alloy
- Ratchet springs: stainless steel, passivated
- Retainer rings: stainless steel, passivated

Ultraminiature 806-012 plugs save size and weight compared to traditional aerospace-grade circular connectors. Rugged ratchet mechanism and unique triple-start mating thread provide improved de-coupling resistance under vibration. Series 806 enhanced performance connectors are intended for use in unpressurized aircraft areas subject to vibration, moisture, and temperature extremes.

How To Order							
SAMPLE PART NUMBER →	806-012 -ME 8-3 S M A						
Product	806-012 = Cable Plug						
Shell Material and Finish	ME = Aluminum, Electroless Nickel MT = Aluminum, Ni/PTFE ZR = Aluminum, Black Zinc-Nickel NF = Aluminum, Olive Drab Cadmium Z1 = Stainless Steel, Passivated						
Arrangement Number (Shell Size - Insert Arr.)	See Table 1						
Contact Type	<table border="0"> <tr> <td>Connector supplied with contacts</td> <td>Connector supplied without contacts</td> </tr> <tr> <td>P = Pin</td> <td>A = Pin</td> </tr> <tr> <td>S = Socket</td> <td>B = Socket</td> </tr> </table>	Connector supplied with contacts	Connector supplied without contacts	P = Pin	A = Pin	S = Socket	B = Socket
Connector supplied with contacts	Connector supplied without contacts						
P = Pin	A = Pin						
S = Socket	B = Socket						
Shell Style	M = Metric accessory threads B = Nano Band platform						
Polarizing Position (Table 2)	A B C D E F						

No. of Contacts	#20HD	#22HD	Arr.	Shell Size
3	●		8-3	8
4		●	8-4	8
5	●		9-5	9
7		●	8-7	8
8	●		10-8	10
10	●		11-10	11
11		●	9-11	9
15		●	10-15	10
15	●		12-15	12
19		●	11-19	11
20	●		14-20	14
26		●	12-26	12
31	●		16-31	16
39		●	14-39	14
41	●		18-41	18
55	●		20-55	20
60		●	16-60	16
69	●		22-69	22
85		●	18-85	18
92	●		24-92	24
110		●	20-110	20
140		●	22-140	22
186		●	24-186	24

Position	A°	B°	C°	D°
A	105	140	215	265
B	102	170	248	305
C	80	150	230	295
D	68	140	205	275
E	64	155	234	304
F	72	120	200	298

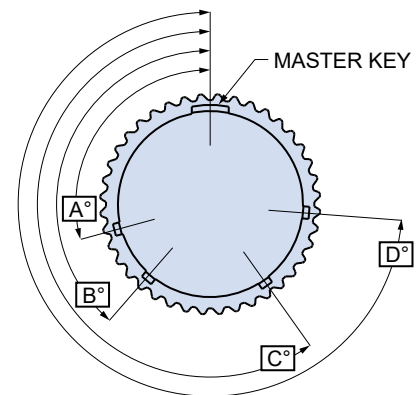

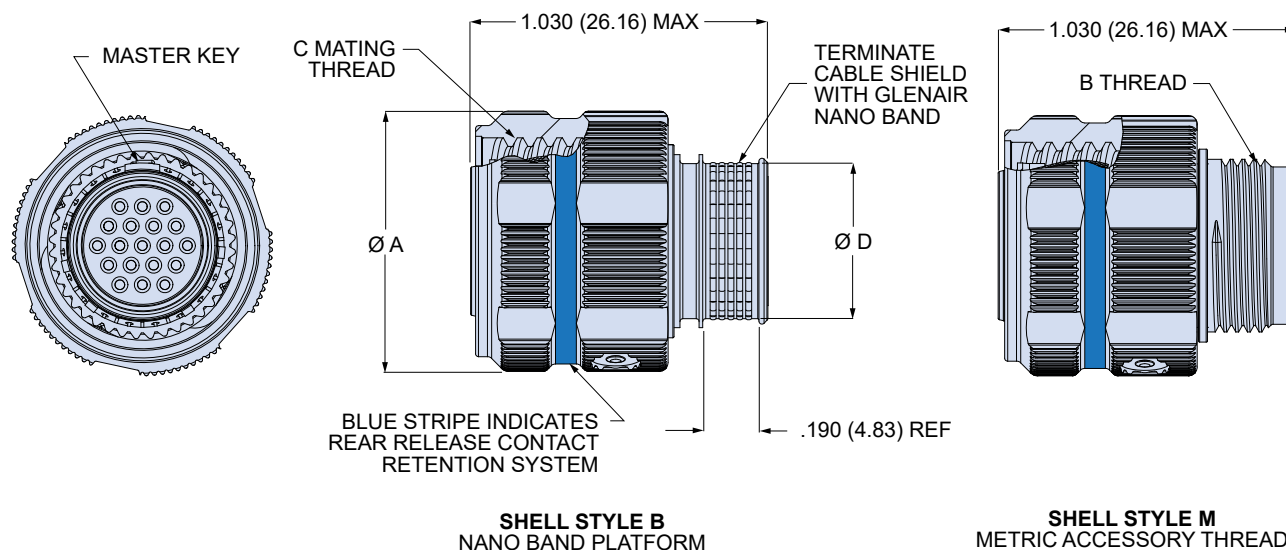

806-012 Plug Dimensions						
Shell Size	øA Max		B Thread	C Mating Thread	øD	
	In.	mm.			In.	mm.
8	.676	17.17	M10x1.0-6g-0.100R	.5000-.067P-.2L-TS-2B	.330	8.38
9	.771	19.58	M12x1.0-6g-0.100R	.5625-.067P-.2L-TS-2B	.409	10.39
10	.832	21.13	M14x1.0-6g-0.100R	.6250-.067P-.2L-TS-2B	.487	12.37
11	.890	22.61	M15x1.0-6g-0.100R	.6875-.067P-.2L-TS-2B	.527	13.39
12	.950	24.13	M17x1.0-6g-0.100R	.7500-.067P-.2L-TS-2B	.606	15.39
14	1.110	28.19	M19x1.0-6g-0.100R	.8750-.067P-.2L-TS-2B	.684	17.37
16	1.170	29.72	M22x1.0-6g-0.100R	1.0000-.067P-.2L-TS-2B	.785	19.94
18	1.350	34.29	M25x1.0-6g-0.100R	1.1250-.067P-.2L-TS-2B	.899	22.83
20	1.470	37.34	M28x1.0-6g-0.100R	1.2500-.067P-.2L-TS-2B	1.046	26.57
22	1.600	40.64	M31x1.0-6g-0.100R	1.3750-.067P-.2L-TS-2B	1.158	29.41
24	1.710	43.43	M34x1.0-6g-0.100R	1.5000-.067P-.2L-TS-2B	1.276	32.41

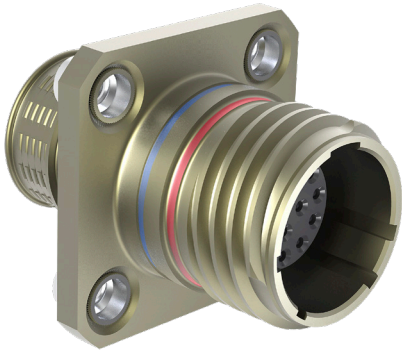

Features

- Triple-start stub ACME mating thread
- High density #20HD and #22HD arrangements for reduced size and weight
- Aerospace-grade materials, construction
- Snap-in crimp contacts

Specifications

- Operating temperature:
Finishes ME, MT, Z1: -65°C to +200°C
Finishes NF, ZR: -65°C to +175°C
- Wire sizes:
#20HD contacts: 20–24 AWG
#22HD contacts: 22–28 AWG
- Dielectric withstanding voltage
#20HD layouts: 1800 Vac
#22HD layouts: 1300 Vac
- Current rating
#20HD contacts 7.5 A
#22HD contacts 5 A
- Mating durability: 500 cycles
- Mechanical shock: EIA-364-27, 300g.
- Vibration (sine): MIL-DTL-38999M, 60g.
- Vibration (random) EIA-364-28 Condition VI, Letter J, 43.92 Grms, +200°C
- High Impact shock: MIL-S-901 Grade A
- Humidity: EIA-364-31 Method 4
- Salt spray (dynamic): EIA-364-26, 500 hours (96 hours for nickel-plated versions)
- Fluid immersion: EIA-364-10
- Altitude immersion: EIA-364-03 75,000 feet altitude

Connector Construction

- Shell: aluminum or stainless steel
- Contacts: copper alloy, gold plating
- Wire grommet: blue fluorosilicone
- Dielectric inserts: high grade rigid dielectric
- Peripheral seal: blue fluorosilicone
- Contact retention clips: copper alloy
- Clinch nuts: stainless steel, passivated
- Retainer rings: stainless steel, passivated

Ultraminiature 806-013 square flange panel receptacles save size and weight compared to traditional aerospace-grade connectors. Series 806 high performance connectors are intended for use in unpressurized aircraft areas subject to vibration, moisture, and temperature extremes. Available with integral Nano Band platform or with metric accessory threads, these connectors feature snap-in, rear release contacts.

How To Order								
SAMPLE PART NUMBER →		806-013	-MT	12-26	P	B	C	A
Product	806-013 = Panel Receptacle, Square Flange, Crimp							
Shell Material and Finish	ME = Aluminum, Electroless Nickel MT = Aluminum, Ni/PTFE ZR = Aluminum, Black Zinc-Nickel NF = Aluminum, Olive Drab Cadmium Z1 = Stainless Steel, Passivated							
Arrangement Number (Shell Size - Insert Arr.)	See Table 1							
Contact Type	Connector supplied with contacts P = Pin S = Socket			Connector supplied without contacts A = Pin B = Socket				
Shell Style	M = Metric accessory threads B = Nano Band platform							
Mounting Hole Style	T = Thru holes C = Clinch nut, #4-40 (rear panel mounting)							
Polarizing Position (Table 2)	A B C D E F							

Table 1
Arrangement Number

No. of Contacts	#20HD	#22HD	Arr.	Shell Size
3	●		8-3	8
4		●	8-4	8
5	●		9-5	9
7		●	8-7	8
8	●		10-8	10
10	●		11-10	11
11		●	9-11	9
15		●	10-15	10
15	●		12-15	12
19		●	11-19	11
20	●		14-20	14
26		●	12-26	12
31	●		16-31	16
39		●	14-39	14
41	●		18-41	18
55	●		20-55	20
60		●	16-60	16
69	●		22-69	22
85		●	18-85	18
92	●		24-92	24
110		●	20-110	20
140		●	22-140	22
186		●	24-186	24

Table 2
Polarizing Positions

Position	A°	B°	C°	D°
A	105	140	215	265
B	102	170	248	305
C	80	150	230	295
D	68	140	205	275
E	64	155	234	304
F	72	120	200	298

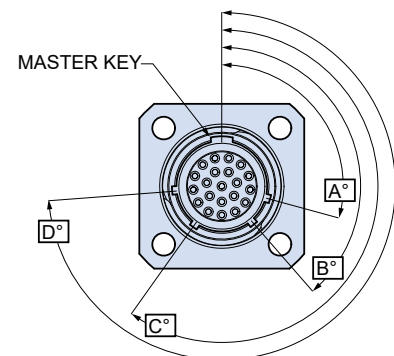

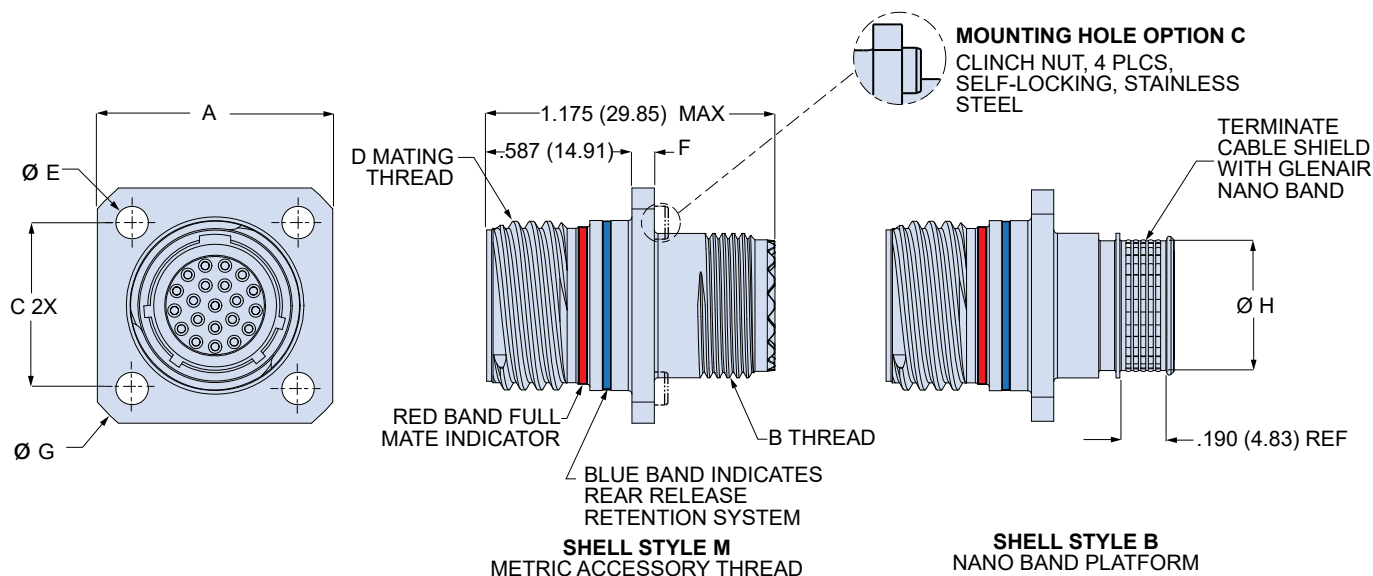

806-013 Receptacle Dimensions

Shell Size	A Max		B Thread	C		D Mating Thread		ØE		F Max		G Max		H Max	
	In.	mm.		In.	mm.	In.	mm.	In.	mm.	In.	mm.	In.	mm.	In.	mm.
8	.822	20.88	M10x1.0-6g-0.100R	.531	13.49	.5000-.067P-.2L-TS-2A	.128	3.25	.100	2.54	1.040	26.42	.330	8.38	
9	.885	22.48	M12x1.0-6g-0.100R	.594	15.09	.5625-.067P-.2L-TS-2A	.128	3.25	.100	2.54	1.130	28.70	.409	10.39	
10	.913	23.19	M14x1.0-6g-0.100R	.625	15.88	.6250-.067P-.2L-TS-2A	.128	3.25	.100	2.54	1.174	29.82	.487	12.37	
11	.944	23.98	M15x1.0-6g-0.100R	.670	17.02	.6875-.067P-.2L-TS-2A	.128	3.25	.100	2.54	1.200	30.48	.527	13.39	
12	1.040	26.42	M17x1.0-6g-0.100R	.765	19.43	.7500-.067P-.2L-TS-2A	.128	3.25	.100	2.54	1.354	34.39	.606	15.39	
14	1.133	28.78	M19x1.0-6g-0.100R	.859	21.82	.8750-.067P-.2L-TS-2A	.128	3.25	.100	2.54	1.510	38.35	.684	17.37	
16	1.227	31.17	M22x1.0-6g-0.100R	.938	23.83	1.0000-.067P-.2L-TS-2A	.128	3.25	.100	2.54	1.620	41.15	.785	19.94	
18	1.320	33.53	M25x1.0-6g-0.100R	1.016	25.81	1.1250-.067P-.2L-TS-2A	.128	3.25	.100	2.54	1.784	45.31	.899	22.83	
20	1.444	36.68	M28x1.0-6g-0.100R	1.109	28.17	1.2500-.067P-.2L-TS-2A	.154	3.91	.125	3.18	1.910	48.51	1.046	26.57	
22	1.570	39.88	M31x1.0-6g-0.100R	1.203	30.56	1.3750-.067P-.2L-TS-2A	.154	3.91	.125	3.18	2.083	52.91	1.158	29.41	
24	1.696	43.08	M34x1.0-6g-0.100R	1.312	33.32	1.5000-.067P-.2L-TS-2A	.154	3.91	.125	3.18	2.200	55.88	1.276	32.41	

806-013 Panel Cutout Dimensions

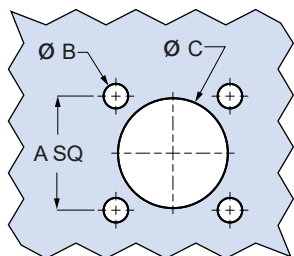

Shell Size	A		ØB with Clinch Nut		ØB without Clinch Nut		ØC	
	In.	mm.	In.	mm.	In.	mm.	In.	mm.
8	.531	13.49	.128	3.25	.128	3.25	.505	12.83
9	.594	15.09	.128	3.25	.128	3.25	.572	14.53
10	.625	15.88	.128	3.25	.128	3.25	.640	16.26
11	.670	17.02	.128	3.25	.128	3.25	.707	17.96
12	.765	19.43	.128	3.25	.128	3.25	.762	19.35
14	.859	21.82	.128	3.25	.128	3.25	.885	22.48
16	.938	23.83	.128	3.25	.128	3.25	1.010	25.65
18	1.016	25.81	.128	3.25	.128	3.25	1.120	28.45
20	1.109	28.17	.128	3.25	.154	3.91	1.270	32.26
22	1.203	30.56	.128	3.25	.154	3.91	1.395	35.43
24	1.312	33.32	.128	3.25	.154	3.91	1.520	38.61

Series 806

Mighty Mouse Mil-Aero Connectors

806-019 Line Receptacle Connectors



Features

- Triple-start stub ACME mating thread
- High density #20HD and #22HD arrangements for reduced size and weight
- Aerospace-grade materials, construction
- Snap-in crimp contacts

Specifications

- Operating temperature:
Finishes ME, MT, Z1: -65°C to +200°C
Finishes NF, ZR: -65°C to +175°C
- Wire sizes:
#20HD contacts: 20–24 AWG
#22HD contacts: 22–28 AWG
- Dielectric withstanding voltage
#20HD layouts: 1800 Vac
#22HD layouts: 1300 Vac
- Current rating
#20HD contacts 7.5 A
#22HD contacts 5 A
- Mating durability: 500 cycles
- Mechanical shock: EIA-364-27, 300g.
- Vibration (sine): MIL-DTL-38999M, 60g.
- Vibration (random) EIA-364-28 Condition VI, Letter J, 43.92 Grms, +200°C
- High Impact shock: MIL-S-901 Grade A
- Humidity: EIA-364-31 Method 4
- Salt spray (dynamic): EIA-364-26, 500 hours (96 hours for nickel-plated versions)
- Fluid immersion: EIA-364-10
- Altitude immersion: EIA-364-03 75,000 feet altitude

Connector Construction

- Shell: aluminum or stainless steel
- Contacts: copper alloy, gold plating
- Wire grommet: fluorosilicone
- Dielectric inserts: high grade rigid dielectric
- Peripheral seal: fluorosilicone
- Contact retention clips: copper alloy
- Retainer rings: stainless steel, passivated

Ultriminiature Series 806 connectors save size and weight compared to traditional aerospace-grade circular connectors. These high performance connectors are suitable for unpressurized aircraft areas subject to vibration, moisture, and temperature extremes. 806-019 free-hanging receptacles feature crimp, snap-in contacts. 20 - 28 AWG wire accommodation. 5 A (#22HD contact) or 7 A (#20HD). Contacts are packaged loose with connector.

How To Order	
SAMPLE PART NUMBER →	806-019 -NF 14-20 P B A
Product	806-019 = Line Receptacle
Shell Material and Finish	ME = Aluminum, Electroless Nickel MT = Aluminum, Ni/PTFE ZR = Aluminum, Black Zinc-Nickel NF = Aluminum, Olive Drab Cadmium Z1 = Stainless Steel, Passivated
Arrangement Number (Shell Size - Insert Arr.)	See Table 1
Contact Type	Connector supplied with contacts P = Pin S = Socket Connector supplied without contacts A = Pin B = Socket
Shell Style	M = Metric accessory threads B = Nano Band platform
Polarizing Position (Table 2)	A B C D E F

Table 1
Arrangement Number

No. of Contacts	#20HD	#22HD	Arr.	Shell Size
3	●		8-3	8
4		●	8-4	8
5	●		9-5	9
7		●	8-7	8
8	●		10-8	10
10	●		11-10	11
11		●	9-11	9
15		●	10-15	10
15	●		12-15	12
19		●	11-19	11
20	●		14-20	14
26		●	12-26	12
31	●		16-31	16
39		●	14-39	14
41	●		18-41	18
55	●		20-55	20
60		●	16-60	16
69	●		22-69	22
85		●	18-85	18
92	●		24-92	24
110		●	20-110	20
140		●	22-140	22
186		●	24-186	24

Table 2
Polarizing Positions

Position	A°	B°	C°	D°
A	105	140	215	265
B	102	170	248	305
C	80	150	230	295
D	68	140	205	275
E	64	155	234	304
F	72	120	200	298

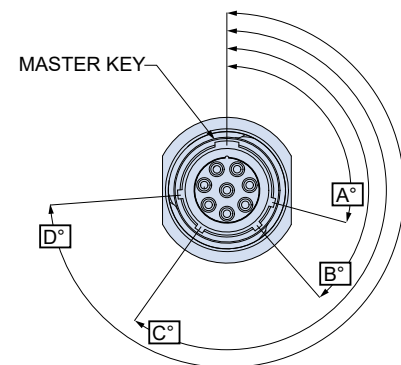

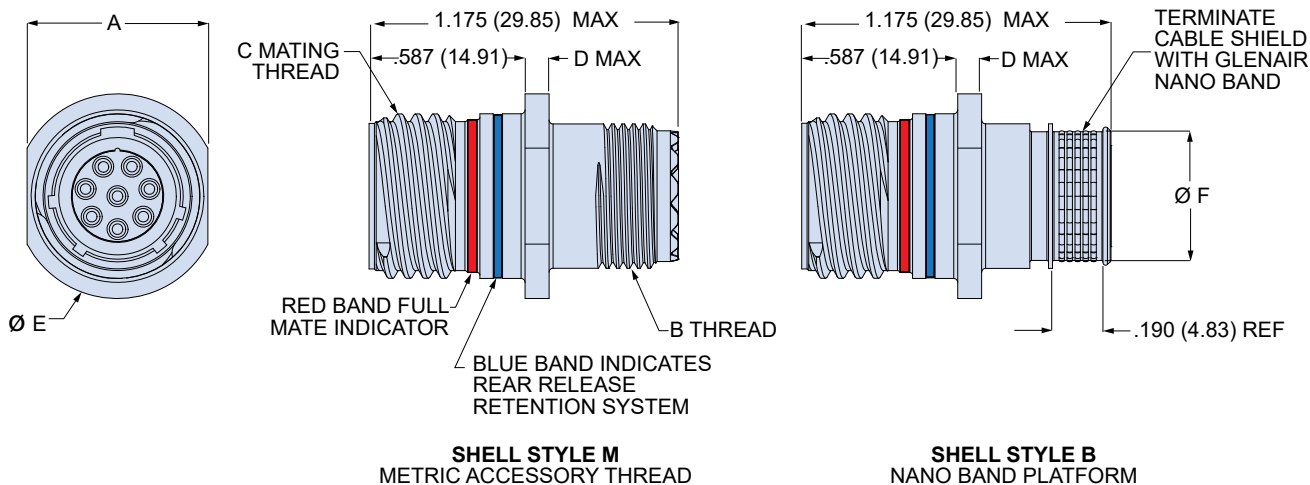

806-019 Receptacle Dimensions

Shell Size	A		B Thread	C Mating Thread	D Max		ØE		ØF	
	In. ±.010	mm. ±0.25			In.	mm.	In.	mm.	In.	mm.
8	.545	13.84	M10x1.0-6g-0.100R	.5000-.067P-.2L-TS-2A	.100	2.54	.635	16.13	.330	8.38
9	.612	15.54	M12x1.0-6g-0.100R	.5625-.067P-.2L-TS-2A	.100	2.54	.702	17.83	.409	10.39
10	.680	17.27	M14x1.0-6g-0.100R	.6250-.067P-.2L-TS-2A	.100	2.54	.770	19.56	.487	12.37
11	.747	18.97	M15x1.0-6g-0.100R	.6875-.067P-.2L-TS-2A	.100	2.54	.837	21.26	.527	13.39
12	.803	20.40	M17x1.0-6g-0.100R	.7500-.067P-.2L-TS-2A	.100	2.54	.893	22.68	.606	15.39
14	.925	23.50	M19x1.0-6g-0.100R	.8750-.067P-.2L-TS-2A	.100	2.54	1.015	25.78	.684	17.37
16	1.050	26.67	M22x1.0-6g-0.100R	1.0000-.067P-.2L-TS-2A	.100	2.54	1.140	28.96	.785	19.94
18	1.160	29.46	M25x1.0-6g-0.100R	1.1250-.067P-.2L-TS-2A	.100	2.54	1.250	31.75	.899	22.83
20	1.310	33.27	M28x1.0-6g-0.100R	1.2500-.067P-.2L-TS-2A	.125	3.18	1.400	35.56	1.046	26.57
22	1.435	36.45	M31x1.0-6g-0.100R	1.3750-.067P-.2L-TS-2A	.125	3.18	1.525	38.74	1.158	29.41
24	1.560	39.62	M34x1.0-6g-0.100R	1.5000-.067P-.2L-TS-2A	.125	3.18	1.650	41.91	1.276	32.41

Series 806

Mighty Mouse Mil-Aero Connectors

806-020 Jam Nut Receptacle Connectors



Ultriminiature Series 806 connectors save size and weight compared to traditional aerospace-grade circular connectors. These high performance connectors are suitable for unpressurized aircraft areas subject to vibration, moisture, and temperature extremes. 806-020 rear panel mount receptacles feature crimp, snap-in contacts. 20 - 28 AWG wire accommodation. 5 A (#22HD contact) or 7 A (#20HD). Contacts are packaged loose with connector.

Features

- Triple-start stub ACME mating thread
- High density #20HD and #22HD arrangements for reduced size and weight
- Aerospace-grade materials, construction
- Snap-in crimp contacts

Specifications

- Operating temperature:
Finishes ME, MT, Z1: -65°C to +200°C
Finishes NF, ZR: -65°C to +175°C
- Wire sizes:
#20HD contacts: 20–24 AWG
#22HD contacts: 22–28 AWG
- Dielectric withstanding voltage
#20HD layouts: 1800 Vac
#22HD layouts: 1300 Vac
- Current rating
#20HD contacts 7.5 A
#22HD contacts 5 A
- Mating durability: 500 cycles
- Mechanical shock: EIA-364-27, 300g.
- Vibration (sine): MIL-DTL-38999M, 60g.
- Vibration (random) EIA-364-28 Condition VI, Letter J, 43.92 Grms, +200°C
- High Impact shock: MIL-S-901 Grade A
- Humidity: EIA-364-31 Method 4
- Salt spray (dynamic): EIA-364-26, 500 hours (96 hours for nickel-plated versions)
- Fluid immersion: EIA-364-10
- Altitude immersion: EIA-364-03 75,000 feet altitude

Connector Construction

- Shell and jam nut: aluminum or stainless steel
- Contacts: copper alloy, gold plating
- Wire grommet: fluorosilicone
- Dielectric inserts: high grade rigid dielectric
- Panel O-ring: fluorosilicone
- Contact retention clips: copper alloy
- Retainer rings: stainless steel, passivated

How To Order							
SAMPLE PART NUMBER →	806-020 -ME 10-15 S M A						
Product	806-020 = Jam Nut Receptacle						
Shell Material and Finish	ME = Aluminum, Electroless Nickel MT = Aluminum, Ni/PTFE ZR = Aluminum, Black Zinc-Nickel NF = Aluminum, Olive Drab Cadmium Z1 = Stainless Steel, Passivated						
Arrangement Number (Shell Size - Insert Arr.)	See Table 1						
Contact Type	<table border="0"> <tr> <td>Connector supplied with contacts</td> <td>Connector supplied without contacts</td> </tr> <tr> <td>P = Pin</td> <td>A = Pin</td> </tr> <tr> <td>S = Socket</td> <td>B = Socket</td> </tr> </table>	Connector supplied with contacts	Connector supplied without contacts	P = Pin	A = Pin	S = Socket	B = Socket
Connector supplied with contacts	Connector supplied without contacts						
P = Pin	A = Pin						
S = Socket	B = Socket						
Shell Style	M = Metric accessory threads B = Nano Band platform						
Polarizing Position (Table 2)	A B C D E F						

No. of Contacts	#20HD	#22HD	Arr.	Shell Size
3	●		8-3	8
4		●	8-4	8
5	●		9-5	9
7		●	8-7	8
8	●		10-8	10
10	●		11-10	11
11		●	9-11	9
15		●	10-15	10
15	●		12-15	12
19		●	11-19	11
20	●		14-20	14
26		●	12-26	12
31	●		16-31	16
39		●	14-39	14
41	●		18-41	18
55	●		20-55	20
60		●	16-60	16
69	●		22-69	22
85		●	18-85	18
92	●		24-92	24
110		●	20-110	20
140		●	22-140	22
186		●	24-186	24

Position	A°	B°	C°	D°
A	105	140	215	265
B	102	170	248	305
C	80	150	230	295
D	68	140	205	275
E	64	155	234	304
F	72	120	200	298

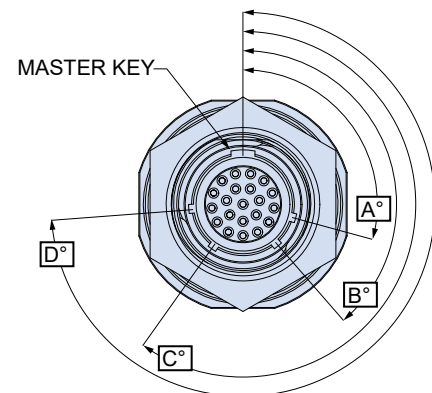

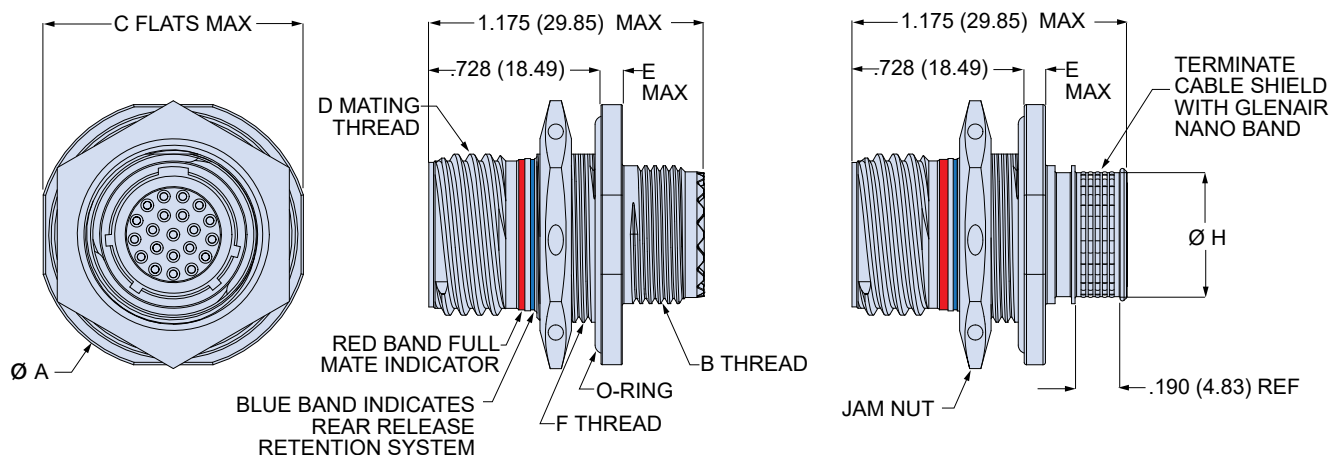

SHELL STYLE M
METRIC ACCESSORY THREAD

SHELL STYLE B
NANO BAND PLATFORM

806-020 Receptacle Dimensions											
Shell Size	ØA Max		B Thread	C Max		D Mating Thread	E Max		F Thread	ØH	
	In.	mm.		In.	mm.		In.	mm.		In.	mm.
8	.980	24.69	M10x1.0-6g-0.100R	.920	23.37	.5000-.067P-2L-TS-2A	.100	2.54	M15x1.0-6g-0.100R	.330	8.38
9	1.040	26.42	M12x1.0-6g-0.100R	.980	24.89	.5625-.067P-2L-TS-2A	.100	2.54	M16x1.0-6g-0.100R	.409	10.39
10	1.110	28.19	M14x1.0-6g-0.100R	1.050	26.67	.6250-.067P-2L-TS-2A	.100	2.54	M18x1.0-6g-0.100R	.487	12.37
11	1.160	29.46	M15x1.0-6g-0.100R	1.110	28.19	.6875-.067P-2L-TS-2A	.100	2.54	M19x1.0-6g-0.100R	.527	13.39
12	1.230	31.24	M17x1.0-6g-0.100R	1.170	29.72	.7500-.067P-2L-TS-2A	.100	2.54	M21x1.0-6g-0.100R	.606	15.39
14	1.360	34.54	M19x1.0-6g-0.100R	1.320	33.53	.8750-.067P-2L-TS-2A	.100	2.54	M24x1.0-6g-0.100R	.684	17.37
16	1.515	38.48	M22x1.0-6g-0.100R	1.444	36.68	1.0000-.067P-2L-TS-2A	.100	2.54	M27x1.0-6g-0.100R	.785	19.94
18	1.610	40.89	M25x1.0-6g-0.100R	1.570	39.88	1.1250-.067P-2L-TS-2A	.100	2.54	M30x1.0-6g-0.100R	.899	22.83
20	1.850	46.99	M28x1.0-6g-0.100R	1.760	44.70	1.2500-.067P-2L-TS-2A	.128	3.25	M34x1.0-6g-0.100R	1.046	26.57
22	2.010	51.05	M31x1.0-6g-0.100R	1.913	48.59	1.3750-.067P-2L-TS-2A	.128	3.25	M37x1.0-6g-0.100R	1.158	29.41
24	2.195	55.75	M34x1.0-6g-0.100R	2.070	52.58	1.5000-.067P-2L-TS-2A	.128	3.25	M41x1.0-6g-0.100R	1.276	32.41

806-020 Jam Nut D-Hole Dimensions				
Shell Size	ØA		B	
	In.	mm.	In.	mm.
8	.601	15.27	.256	6.50
9	.640	16.26	.287	7.29
10	.719	18.26	.318	8.08
11	.759	19.28	.350	8.89
12	.837	21.26	.381	9.67
14	.955	24.26	.443	11.25
16	1.073	27.25	.505	12.83
18	1.192	30.28	.568	14.43
20	1.349	34.26	.630	16.00
22	1.467	37.26	.693	17.60
24	1.624	41.25	.755	19.18

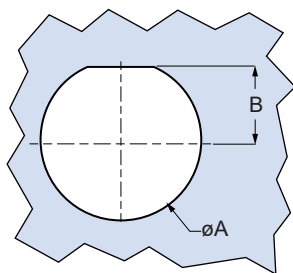

Series 806

Mighty Mouse Mil-Aero Connectors

806-021 Jam Nut Receptacle Connectors, PC Tail Contacts



Features

- Triple-start stub ACME mating thread
- High density #20HD and #22HD arrangements for reduced size and weight
- Aerospace-grade materials, construction
- Integral PC board standoffs
- Threaded holes for secure attachment to rigid or flex circuits
- Alignment post

Specifications

- Operating temperature:
Finishes ME, MT, Z1: -65°C to +200°C
Finishes NF, ZR: -65°C to +175°C
- Dielectric withstanding voltage
#20HD layouts: 1800 Vac
#22HD layouts: 1300 Vac
- Current rating
#20HD contacts 7.5 A
#22HD contacts 5 A
- Mating durability: 500 cycles
- Mechanical shock: EIA-364-27, 300g.
- Vibration (sine): MIL-DTL-38999M, 60g.
- Vibration (random) EIA-364-28 Condition VI, Letter J, 43.92 Grms, +200°C
- High Impact shock: MIL-S-901 Grade A
- Humidity: EIA-364-31 Method 4
- Salt spray (dynamic): EIA-364-26, 500 hours (96 hours for nickel-plated versions)
- Fluid immersion: EIA-364-10
- Altitude immersion: EIA-364-03 75,000 feet altitude
- Indirect Lightning Strike: EIA-364-75 Type B Level 2 10kA Peak

Connector Construction

- Shell and jam nut: aluminum or stainless steel
- Contacts: copper alloy, gold plating
- Potting compound: epoxy
- Dielectric inserts: high grade rigid dielectric
- Panel O-ring: fluorosilicone

806-021 panel mount jam nut receptacles feature potted-in-place printed circuit board terminals, integral standoffs and threaded holes for secure attachment to rigid or flex circuit boards. Gold-plated terminals are factory-installed, non-removeable and sealed with epoxy. Boss on shell flange guarantees correct connector orientation. These high performance, parylene-compatible connectors are suitable for unpressurized aircraft areas subject to vibration, moisture, and temperature extremes.

How To Order	
SAMPLE PART NUMBER	806-021 -ME 10-15 S 2 A
Product	806-021 = Jam Nut Receptacle, PC Tails
Shell Material and Finish	ME = Aluminum, Electroless Nickel MT = Aluminum, Ni/PTFE ZR = Aluminum, Black Zinc-Nickel NF = Aluminum, Olive Drab Cadmium Z1 = Stainless Steel, Passivated
Arrangement Number (Shell Size - Insert Arr.)	See Table 1
Contact Type	P = Pin S = Socket
PC Tail Length	1 = .125" (3.18 mm.) 2 = .250" (6.35 mm.)
Polarizing Position (Table 2)	A B C D E F

No. of Contacts	#20HD	#22HD	Arr.	Shell Size
3	●		8-3	8
4		●	8-4	8
5	●		9-5	9
7		●	8-7	8
8	●		10-8	10
10	●		11-10	11
11		●	9-11	9
15		●	10-15	10
15	●		12-15	12
19		●	11-19	11
20	●		14-20	14
26		●	12-26	12
31	●		16-31	16
39		●	14-39	14
41	●		18-41	18
55	●		20-55	20
60		●	16-60	16
69	●		22-69	22
85		●	18-85	18
92	●		24-92	24
110		●	20-110	20
140	●		22-140	22
186		●	24-186	24

Position	A°	B°	C°	D°
A	105	140	215	265
B	102	170	248	305
C	80	150	230	295
D	68	140	205	275
E	64	155	234	304
F	72	120	200	298

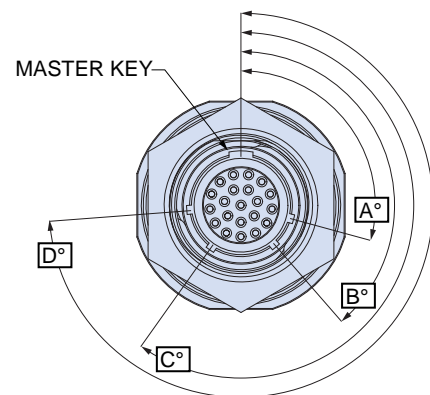

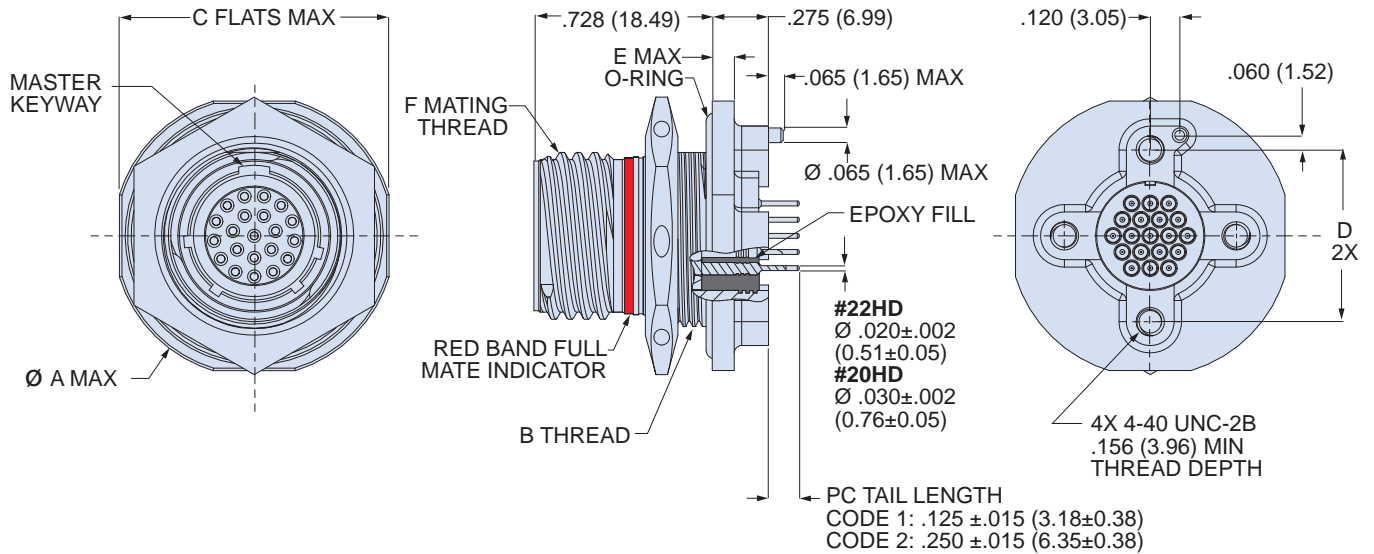

806-021 Receptacle Dimensions

Shell Size	ØA Max		B Thread	C Max		D		E Max		F Mating Thread
	In.	mm.		In.	mm.	In.	mm.	In.	mm.	
8	.980	24.69	M15x1.0-6g-0.100R	.920	23.37	.534	13.56	.100	2.54	.5000-.067P-2L-TS-2A
9	1.040	26.42	M16x1.0-6g-0.100R	.980	24.89	.579	14.71	.100	2.54	.5625-.067P-2L-TS-2A
10	1.110	28.19	M18x1.0-6g-0.100R	1.050	26.67	.679	17.25	.100	2.54	.6250-.067P-2L-TS-2A
11	1.160	29.46	M19x1.0-6g-0.100R	1.110	28.19	.734	18.64	.100	2.54	.6875-.067P-2L-TS-2A
12	1.230	31.24	M21x1.0-6g-0.100R	1.170	29.72	.804	20.42	.100	2.54	.7500-.067P-2L-TS-2A
14	1.360	34.54	M24x1.0-6g-0.100R	1.320	33.53	.891	22.63	.100	2.54	.8750-.067P-2L-TS-2A
16	1.515	38.48	M27x1.0-6g-0.100R	1.444	36.68	1.049	26.64	.100	2.54	1.0000-.067P-2L-TS-2A
18	1.610	40.89	M30x1.0-6g-0.100R	1.570	39.88	1.148	29.16	.100	2.54	1.1250-.067P-2L-TS-2A
20	1.850	46.99	M34x1.0-6g-0.100R	1.760	44.70	1.252	31.80	.128	3.25	1.2500-.067P-2L-TS-2A
22	2.010	51.05	M37x1.0-6g-0.100R	1.913	48.59	1.369	34.77	.128	3.25	1.3750-.067P-2L-TS-2A
24	2.195	55.75	M41x1.0-6g-0.100R	2.070	52.58	1.509	38.33	.128	3.25	1.5000-.067P-2L-TS-2A

806-021 Jam Nut D-Hole Dimensions

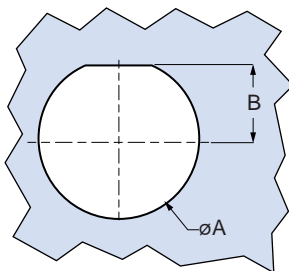

Shell Size	ØA		B	
	In.	mm.	In.	mm.
8	+0.005/-0.00	+0.13/-0.00	+0.005/-0.00	6.50
9	.640	16.26	.287	7.29
10	.719	18.26	.318	8.08
11	.759	19.28	.350	8.89
12	.837	21.26	.381	9.67
14	.955	24.26	.443	11.25
16	1.073	27.25	.505	12.83
18	1.192	30.28	.568	14.43
20	1.349	34.26	.630	16.00
22	1.467	37.26	.693	17.60
24	1.624	41.25	.755	19.18

Series 806

Mighty Mouse Mil-Aero Connectors

806-022 Square Flange Receptacle Connectors, PC Tail Contacts



806-022 square flange receptacles feature potted-in-place printed circuit board terminals, integral standoffs and threaded holes for secure attachment to rigid or flex circuit boards. Ultraminiature Series 806 connectors save size and weight compared to legacy aerospace-grade circular connectors. These ultraminiature, high performance, parylene-compatible connectors are suitable for unpressurized aircraft areas subject to vibration, moisture, and temperature extremes.

Features

- Triple-start stub ACME mating thread
- High density #20HD and #22HD arrangements for reduced size and weight
- Aerospace-grade materials, construction
- Integral PC board standoffs
- Threaded holes for secure attachment to rigid or flex circuits
- Alignment post

Specifications

- Operating temperature:
Finishes ME, MT, Z1: -65°C to +200°C
Finishes NF, ZR: -65°C to +175°C
- Dielectric withstanding voltage
#20HD layouts: 1800 Vac
#22HD layouts: 1300 Vac
- Current rating
#20HD contacts 7.5 A
#22HD contacts 5 A
- Mating durability: 500 cycles
- Mechanical shock: EIA-364-27, 300g.
- Vibration (sine): MIL-DTL-38999M, 60g.
- Vibration (random) EIA-364-28 Condition VI, Letter J, 43.92 Grms, +200°C
- High Impact shock: MIL-S-901 Grade A
- Humidity: EIA-364-31 Method 4
- Salt spray (dynamic): EIA-364-26, 500 hours (96 hours for nickel-plated versions)
- Fluid immersion: EIA-364-10
- Altitude immersion: EIA-364-03 75,000 feet altitude
- Indirect Lightning Strike: EIA-364-75 Type B Level 2 10kA Peak

Connector Construction

- Shell, jam nut: aluminum or stainless steel
- Contacts: copper alloy, gold plating
- Potting compound: epoxy
- Interfacial seal and peripheral seal: fluorosilicone
- Dielectric inserts: high grade rigid dielectric
- Clinch nuts: stainless steel, passivated

How To Order							
SAMPLE PART NUMBER	806-022	-ME	11-19	P	1	C	A
Product	806-022 = Square Flange Receptacle, PC Tails						
Shell Material and Finish	ME = Aluminum, Electroless Nickel MT = Aluminum, Ni/PTFE ZR = Aluminum, Black Zinc-Nickel NF = Aluminum, Olive Drab Cadmium Z1 = Stainless Steel, Passivated						
Arrangement Number (Shell Size - Insert Arr.)	See Table 1						
Contact Type	P = Pin S = Socket						
PC Tail Length	1 = .125" (3.18 mm.) 2 = .250" (6.35 mm.)						
Mounting Hole Style	T = Thru holes C = Clinch nut, #4-40 (rear panel mounting)						
Polarizing Position (Table 2)	A B C D E F						

No. of Contacts	#20HD	#22HD	Arr.	Shell Size
3	●		8-3	8
4		●	8-4	8
5	●		9-5	9
7		●	8-7	8
8	●		10-8	10
10	●		11-10	11
11		●	9-11	9
15		●	10-15	10
15	●		12-15	12
19		●	11-19	11
20	●		14-20	14
26		●	12-26	12
31	●		16-31	16
39		●	14-39	14
41	●		18-41	18
55	●		20-55	20
60		●	16-60	16
69	●		22-69	22
85		●	18-85	18
92	●		24-92	24
110		●	20-110	20
140	●		22-140	22
186		●	24-186	24

Position	A°	B°	C°	D°
A	105	140	215	265
B	102	170	248	305
C	80	150	230	295
D	68	140	205	275
E	64	155	234	304
F	72	120	200	298

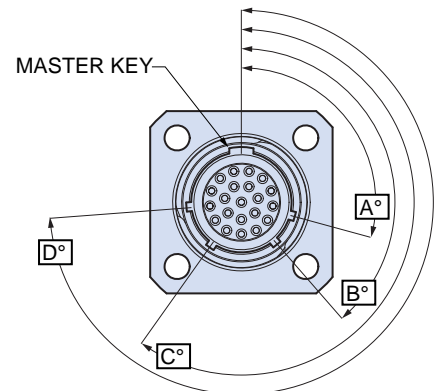

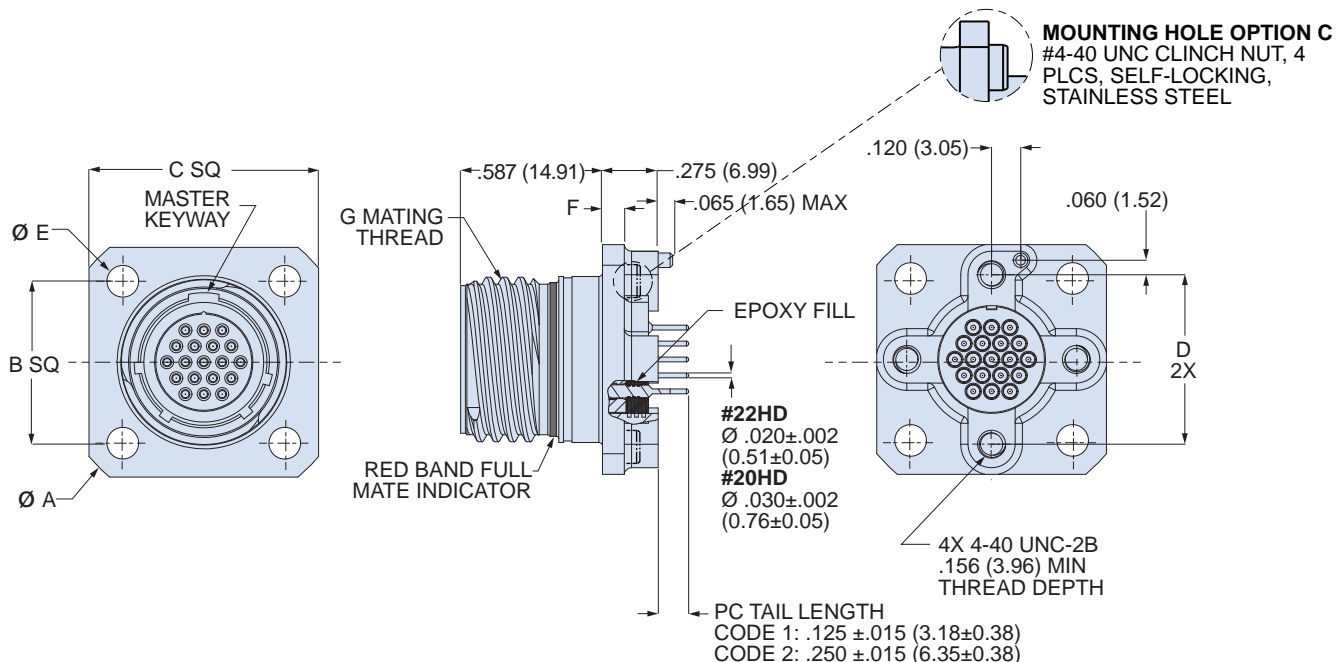

806-022 Receptacle Dimensions

Shell Size	A Max		B		C Max		D		ØE		F Max		G Mating Thread	
	In.	mm.	In.	mm.	In.	mm.	In.	mm.	In.	mm.	In.	mm.	In.	mm.
8	1.040	26.42	.531	13.49	.822	20.88	.534	13.56	.128	3.25	.100	2.54	.5000-.067P-.2L-TS-2A	
9	1.130	28.70	.594	15.09	.885	22.48	.579	14.71	.128	3.25	.100	2.54	.5625-.067P-.2L-TS-2A	
10	1.174	29.82	.625	15.88	.913	23.19	.679	17.25	.128	3.25	.100	2.54	.6250-.067P-.2L-TS-2A	
11	1.240	31.50	.670	17.02	.960	24.38	.734	18.64	.128	3.25	.100	2.54	.6875-.067P-.2L-TS-2A	
12	1.354	34.39	.765	19.43	1.040	26.42	.804	20.42	.128	3.25	.100	2.54	.7500-.067P-.2L-TS-2A	
14	1.510	38.35	.859	21.82	1.133	28.78	.891	22.63	.128	3.25	.100	2.54	.8750-.067P-.2L-TS-2A	
16	1.620	41.15	.938	23.83	1.242	31.55	1.049	26.64	.128	3.25	.100	2.54	1.0000-.067P-.2L-TS-2A	
18	1.784	45.31	1.016	25.81	1.343	34.11	1.148	29.16	.128	3.25	.100	2.54	1.1250-.067P-.2L-TS-2A	
20	1.910	48.51	1.109	28.17	1.444	36.68	1.252	31.80	.154	3.91	.125	3.18	1.2500-.067P-.2L-TS-2A	
22	2.083	52.91	1.203	30.56	1.570	39.88	1.369	34.77	.154	3.91	.125	3.18	1.3750-.067P-.2L-TS-2A	
24	2.200	55.88	1.312	33.35	1.704	43.28	1.509	38.33	.154	3.91	.125	3.18	1.5000-.067P-.2L-TS-2A	

806-022 Panel Cutout Dimensions

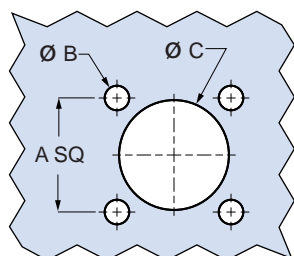

Shell Size	A		ØB with Clinch Nut		ØB without Clinch Nut		ØC	
	In.	mm.	In.	mm.	In.	mm.	In.	mm.
8	.531	13.49	.128	3.25	.128	3.25	.509	12.93
9	.594	15.09	.128	3.25	.128	3.25	.577	14.66
10	.625	15.88	.128	3.25	.128	3.25	.645	16.38
11	.670	17.02	.128	3.25	.128	3.25	.712	18.08
12	.765	19.43	.128	3.25	.128	3.25	.768	19.51
14	.859	21.82	.128	3.25	.128	3.25	.890	22.61
16	.938	23.83	.128	3.25	.128	3.25	1.015	25.78
18	1.016	25.81	.128	3.25	.128	3.25	1.125	28.58
20	1.109	28.17	.128	3.25	.154	3.91	1.275	32.39
22	1.203	30.56	.128	3.25	.154	3.91	1.400	36.56
24	1.312	33.32	.128	3.25	.154	3.91	1.525	38.74



Features

- Glass-to-metal seal
- Non-removable solder cup or PC tail contacts
- High density #20HD and #22HD arrangements for reduced size and weight
- Aerospace-grade materials, construction

Specifications

- Operating temperature: -65°C to +200°C
- Leak Rate: 1E-7 cm³/s at 1 ATM pressure differential
- Dielectric withstanding voltage
#20HD layouts: 1800 Vac
#22HD layouts: 1300 Vac
- Current rating
#20HD contacts 5 A max.
#22HD contacts 3 A max.
- Shell-to-Shell Conductivity: 10 mV max.
- Mating durability: 500 cycles
- Mechanical shock: EIA-364-27, 300g.
- Vibration (sine): MIL-DTL-38999M, 60g.
- Vibration (random) EIA-364-28 Condition VI, Letter J, 43.92 Grms, +200°C
- High Impact shock: MIL-S-901 Grade A
- Indirect Lightning Strike: EIA-364-75 Type B Level 2 10kA Peak

Connector Construction

- Shell and jam-nut: 316L CRES
- Shell (-13 only): 304L CRES
- Hermetic contacts: nickel-iron alloy, gold plated
- Socket contacts: copper alloy, gold plated
- Insulator, hermetic: vitreous glass
- Interfacial seal, peripheral seal, O-ring: fluorosilicone
- Insulator, socket: high grade rigid dielectric

Series 806 hermetic receptacles feature 304L stainless steel shells and glass-to-metal seals. Rated for -65°C to +200°C temperature range. Ultraminiature Series 806 connectors save size and weight compared to legacy aerospace-grade hermetic connectors. These high performance, parylene-compatible connectors are suitable for unpressurized aircraft areas subject to vibration, moisture, and temperature extremes. Equipped with low-profile, non-threaded standoff. For ultra-light, aluminum hermetic performance, see part no. 806-028.

How To Order	
SAMPLE PART NUMBER	806-025 -07 Z1 8-3 C A
Product	806-025 = Hermetic Receptacle
Mounting Type	02 = Square Flange 07 = Jam Nut 13 = Weld Mount
Shell Finish	Z1 = Passivated ZL = Nickel Plated
Arrangement Number (Shell Size - Insert Arr.)	See Table 1
Contact Type	C = Pin, PC Terminal D = Socket, PC Terminal P = Pin, Solder Cup S = Socket, Solder Cup
Polarizing Position (Table 2)	A B C D E F

No. of Contacts	#20HD	#22HD	Arr.	Shell Size
3	●		8-3	8
4		●	8-4	8
5	●		9-5	9
7		●	8-7	8
8	●		10-8	10
10	●		11-10	11
11		●	9-11	9
15		●	10-15	10
15	●		12-15	12
19		●	11-19	11
20	●		14-20	14
26		●	12-26	12
31	●		16-31	16
39		●	14-39	14
41	●		18-41	18
55	●		20-55	20
60		●	16-60	16
69	●		22-69	22
85		●	18-85	18
92	●		24-92	24
110		●	20-110	20
140		●	22-140	22
186		●	24-186	24

Position	A°	B°	C°	D°
A	105	140	215	265
B	102	170	248	305
C	80	150	230	295
D	68	140	205	275
E	64	155	234	304
F	72	120	200	298

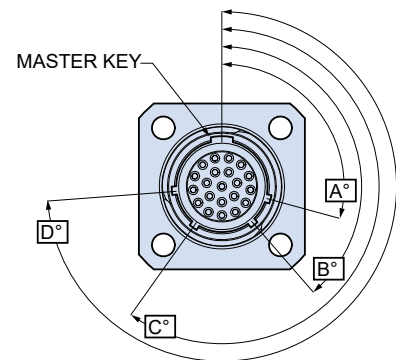



806-025-02 Square Flange Receptacle Dimensions

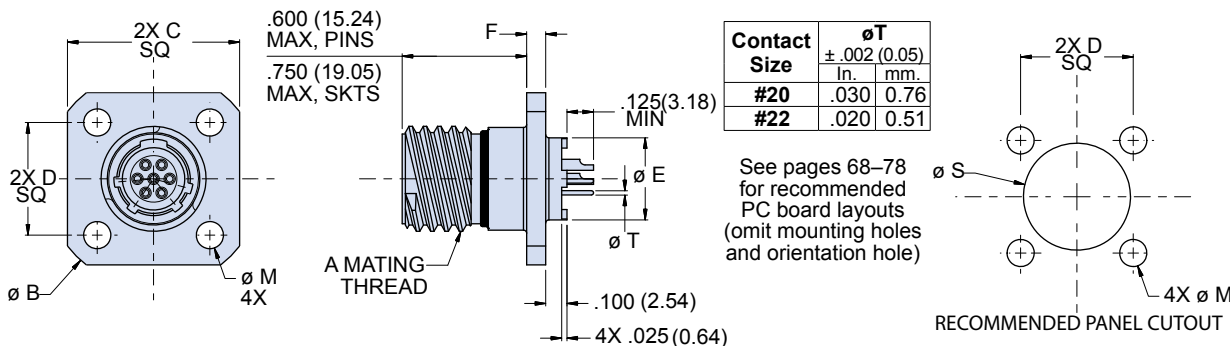

Contact Size	ØT	
	±.002 (0.05)	
	In.	mm.
#20	.030	0.76
#22	.020	0.51

See pages 68–78 for recommended PC board layouts (omit mounting holes and orientation hole)

Shell Size	A Mating Thread	ØB Max.		C Max		D		ØE		F Max		Ø M		Ø S	
		In.	mm.	In.	mm.	In.	mm.	In.	mm.	In.	mm.	In.	mm.	In.	mm.
8	.5000-.067P-.2L-TS-2A	1.040	26.42	.822	20.88	.531	13.49	.387	9.83	.100	2.54	.128	3.25	.509	12.93
9	.5625-.067P-.2L-TS-2A	1.130	28.70	.885	22.48	.594	15.09	.468	11.89	.100	2.54	.128	3.25	.577	14.66
10	.6250-.067P-.2L-TS-2A	1.174	29.82	.913	23.19	.625	15.88	.546	13.87	.100	2.54	.128	3.25	.645	16.38
11	.6875-.067P-.2L-TS-2A	1.240	31.50	.960	24.38	.670	17.02	.586	14.88	.100	2.54	.128	3.25	.712	18.08
12	.7500-.067P-.2L-TS-2A	1.354	34.39	1.040	26.42	.765	19.43	.663	16.84	.100	2.54	.128	3.25	.768	19.51
14	.8750-.067P-.2L-TS-2A	1.510	38.35	1.133	28.78	.859	21.82	.743	18.87	.100	2.54	.128	3.25	.890	22.61
16	1.0000-.067P-.2L-TS-2A	1.620	41.15	1.227	31.17	.938	23.83	.842	21.39	.100	2.54	.128	3.25	1.015	25.78
18	1.1250-.067P-.2L-TS-2A	1.784	45.31	1.320	33.53	1.016	25.81	.959	24.36	.100	2.54	.128	3.25	1.125	28.58
20	1.2500-.067P-.2L-TS-2A	1.910	48.51	1.444	36.68	1.109	28.17	1.105	28.07	.125	3.18	.154	3.91	1.275	32.39
22	1.3750-.067P-.2L-TS-2A	2.083	52.91	1.570	39.88	1.203	30.56	1.215	30.86	.125	3.18	.154	3.91	1.400	36.56
24	1.5000-.067P-.2L-TS-2A	2.200	55.88	1.696	43.08	1.312	33.32	1.335	33.91	.125	3.18	.154	3.91	1.525	38.74

806-025-07 Jam Nut Receptacle Dimensions

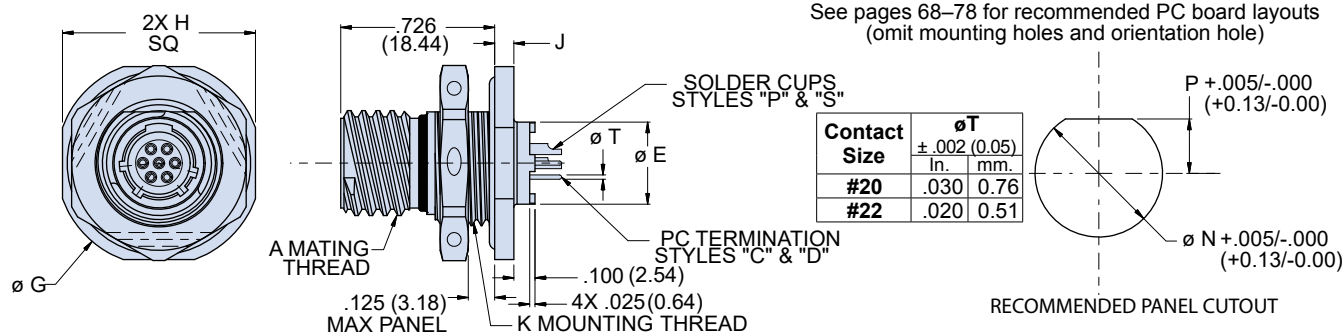

See pages 68–78 for recommended PC board layouts (omit mounting holes and orientation hole)

Contact Size	ØT	
	±.002 (0.05)	
	In.	mm.
#20	.030	0.76
#22	.020	0.51

Shell Size	A Mating Thread	ØE		G Max		H Max		J Max		K Thread	Ø N		P	
		In.	mm.	In.	mm.	In.	mm.	In.	mm.		In.	mm.	In.	mm.
8	.5000-.067P-.2L-TS-2A	.387	9.83	.980	24.69	.920	23.37	.100	2.54	M15x1.0-6g-0.100R	.601	15.27	.256	6.50
9	.5625-.067P-.2L-TS-2A	.468	11.89	1.040	26.42	.980	24.89	.100	2.54	M16x1.0-6g-0.100R	.640	16.26	.287	7.29
10	.6250-.067P-.2L-TS-2A	.546	13.87	1.110	28.19	1.050	26.67	.100	2.54	M18x1.0-6g-0.100R	.719	18.26	.318	8.08
11	.6875-.067P-.2L-TS-2A	.586	14.88	1.160	29.46	1.110	28.19	.100	2.54	M19x1.0-6g-0.100R	.759	19.28	.350	8.89
12	.7500-.067P-.2L-TS-2A	.663	16.84	1.230	31.24	1.170	29.72	.100	2.54	M21x1.0-6g-0.100R	.837	21.26	.381	9.67
14	.8750-.067P-.2L-TS-2A	.743	18.87	1.360	34.54	1.320	33.53	.100	2.54	M24x1.0-6g-0.100R	.955	24.26	.443	11.25
16	1.0000-.067P-.2L-TS-2A	.842	21.39	1.515	38.48	1.444	36.68	.100	2.54	M27x1.0-6g-0.100R	1.073	27.25	.505	12.83
18	1.1250-.067P-.2L-TS-2A	.959	24.36	1.610	40.89	1.570	39.88	.100	2.54	M30x1.0-6g-0.100R	1.192	30.28	.568	14.43
20	1.2500-.067P-.2L-TS-2A	1.105	28.07	1.850	46.99	1.760	44.70	.128	3.25	M34x1.0-6g-0.100R	1.349	34.26	.630	16.00
22	1.3750-.067P-.2L-TS-2A	1.215	30.86	2.010	51.05	1.913	48.59	.128	3.25	M37x1.0-6g-0.100R	1.467	37.26	.693	17.60
24	1.5000-.067P-.2L-TS-2A	1.335	33.91	2.195	55.75	2.070	52.58	.128	3.25	M41x1.0-6g-0.100R	1.624	41.25	.755	19.18



806-025-13 Weld Mount Receptacle Dimensions

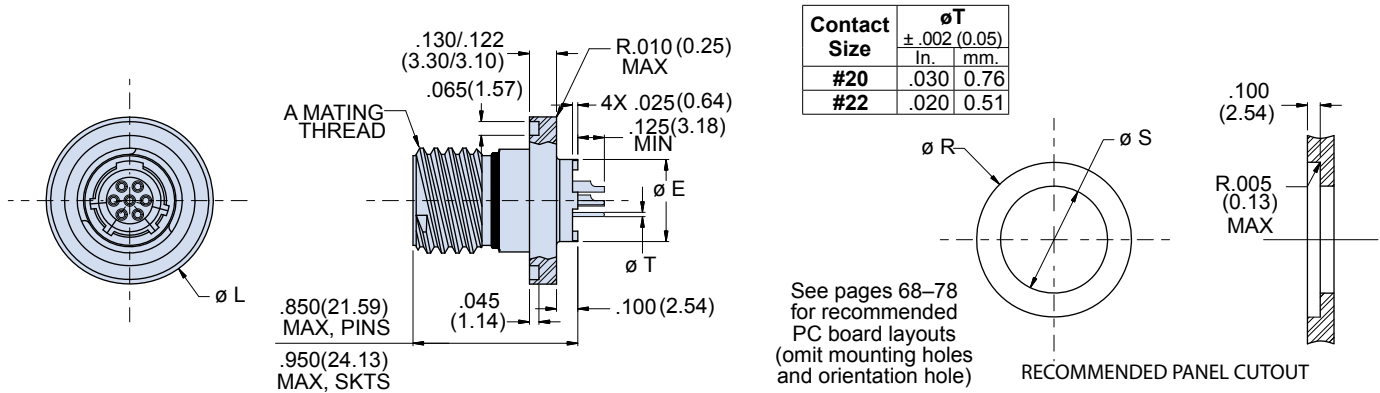

Shell Size	A Mating Thread	øE		L ± .002 (0.05)		Ø R ± .002 (0.05)		Ø S	
		In.	mm.	In.	mm.	In.	mm.	In.	mm.
8	.5000-.067P-.2L-TS-2A	.387	9.83	.788	20.02	.793	20.14	.509	12.93
9	.5625-.067P-.2L-TS-2A	.468	11.89	.912	23.16	.917	23.29	.577	14.66
10	.6250-.067P-.2L-TS-2A	.546	13.87	.975	24.77	.980	24.64	.645	16.38
11	.6875-.067P-.2L-TS-2A	.586	14.88	1.038	26.37	1.043	26.49	.712	18.08
12	.7500-.067P-.2L-TS-2A	.663	16.84	1.100	27.94	1.105	27.94	.768	19.51
14	.8750-.067P-.2L-TS-2A	.743	18.87	1.225	31.12	1.230	31.24	.890	22.61
16	1.0000-.067P-.2L-TS-2A	.842	21.39	1.350	34.29	1.355	34.42	1.015	25.78
18	1.1250-.067P-.2L-TS-2A	.959	24.36	1.475	37.47	1.480	37.59	1.125	28.58
20	1.2500-.067P-.2L-TS-2A	1.105	28.07	1.600	40.64	1.605	40.77	1.275	32.39
22	1.3750-.067P-.2L-TS-2A	1.215	30.86	1.725	43.82	1.730	43.94	1.400	36.56
24	1.5000-.067P-.2L-TS-2A	1.335	33.91	1.850	46.99	1.855	47.12	1.525	38.74

Series 806

Mighty Mouse Mil-Aero Connectors

806-026 Hermetic Receptacles, PC Tails, Threaded Standoff



Features

- Glass-to-metal seal
- Non-removable PC tail contacts
- Threaded holes for attaching to printed circuit boards
- High density #20HD and #22HD arrangements for reduced size and weight
- Aerospace-grade materials, construction

Specifications

- Operating temperature: -65°C to +200°C
- Leak Rate: 1E-7 cm³/s at 1 ATM pressure differential
- Dielectric withstanding voltage
#20HD layouts: 1800 Vac
#22HD layouts: 1300 Vac
- Current rating
#20HD contacts 5 A max.
#22HD contacts 3 A max.
- Shell-to-Shell Conductivity: 10 mV max.
- Mating durability: 500 cycles
- Mechanical shock: EIA-364-27, 300g.
- Vibration (sine): MIL-DTL-38999M, 60g.
- Vibration (random) EIA-364-28 Condition VI, Letter J, 43.92 Grms, +200°C
- High Impact shock: MIL-S-901 Grade A
- Indirect Lightning Strike: EIA-364-75 Type B Level 2 10kA Peak

Connector Construction

- Shell and jam nut: 316L CRES
- Hermetic contacts: nickel-iron alloy, gold plated
- Socket contacts: copper alloy, gold plated
- Insulator, hermetic: vitreous glass
- Interfacial seal, peripheral seal, O-ring: fluorosilicone
- Insulator, socket: high grade rigid dielectric

Series 806 hermetic jam nut receptacles feature 304L stainless steel shells and glass-to-metal seals. Rated for -65°C to +200°C temperature range. Ultraminiature Series 806 connectors save size and weight compared to legacy aerospace-grade circular hermetic connectors. These high performance, parylene-compatible connectors are suitable for unpressurized aircraft areas subject to vibration, moisture, and temperature extremes. Equipped with low-profile, threaded standoff. For ultra-light, aluminum hermetic performance, see part no. 806-028.

How To Order	
SAMPLE PART NUMBER	806-026 -02 Z1 8-3 C 1 A
Product	806-026 = Hermetic Receptacle, PC Tails, Board Mount Flange
Mounting Type	02 = Square Flange 07 = Jam Nut
Shell Finish	Z1 = Passivated ZL = Nickel Plated
Arrangement Number (Shell Size - Insert Arr.)	See Table 1
Contact Type	C = Pin, PC Terminal D = Socket, PC Terminal
PC Tail Length	1 = .125" (3.18 mm.) 2 = .250" (6.35 mm.)
Polarizing Position (Table 2)	A B C D E F

Table 1
Arrangement Number

No. of Contacts	#20HD	#22HD	Arr.	Shell Size
3	●		8-3	8
4		●	8-4	8
5	●		9-5	9
7		●	8-7	8
8	●		10-8	10
10	●		11-10	11
11		●	9-11	9
15		●	10-15	10
15	●		12-15	12
19	●	●	11-19	11
20	●		14-20	14
26		●	12-26	12
31	●		16-31	16
39		●	14-39	14
41	●		18-41	18
55	●		20-55	20
60		●	16-60	16
69	●		22-69	22
85		●	18-85	18
92	●		24-92	24
110		●	20-110	20
140		●	22-140	22
186		●	24-186	24

Table 2
Polarizing Positions

Position	A°	B°	C°	D°
A	105	140	215	265
B	102	170	248	305
C	80	150	230	295
D	68	140	205	275
E	64	155	234	304
F	72	120	200	298

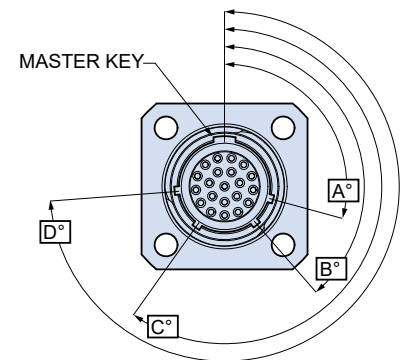

806-026-02 Square Flange Receptacle Dimensions

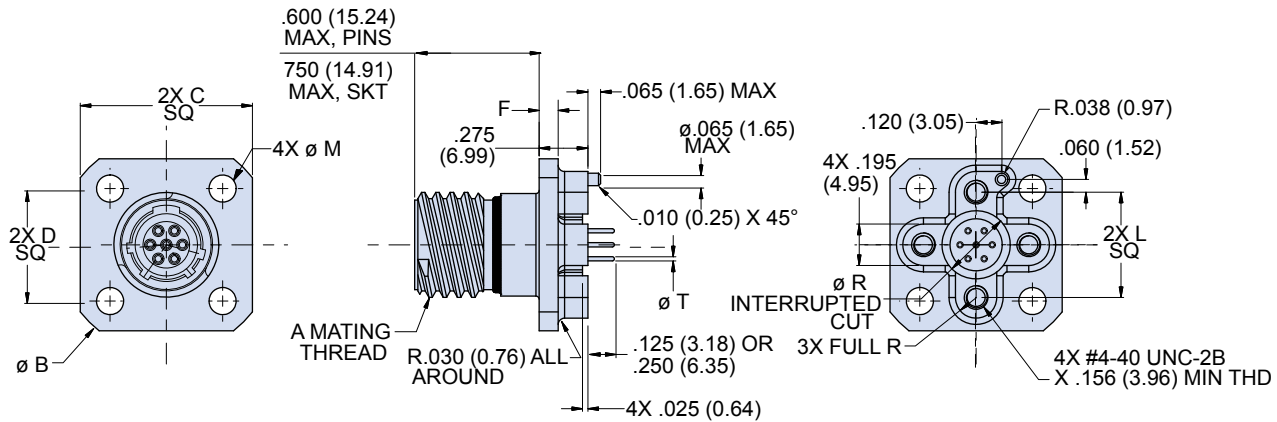

Shell Size	A Mating Thread	ϕB Max.		C Max		D		F Max		L		ϕM		ϕR		ϕS	
		In.	mm.	In.	mm.	In.	mm.	In.	mm.	In.	mm.	In.	mm.	In.	mm.	In.	mm.
8	.5000-.067P-.2L-TS-2A	1.040	26.42	.822	20.88	.531	13.49	.100	2.54	.534	13.56	.128	3.25	.325	8.26	.509	12.93
9	.5625-.067P-.2L-TS-2A	1.130	28.70	.885	22.48	.594	15.09	.100	2.54	.579	14.71	.128	3.25	.405	10.29	.577	14.66
10	.6250-.067P-.2L-TS-2A	1.174	29.82	.913	23.19	.625	15.88	.100	2.54	.679	17.25	.128	3.25	.465	11.81	.645	16.38
11	.6875-.067P-.2L-TS-2A	1.240	31.50	.960	24.38	.670	17.02	.100	2.54	.734	18.64	.128	3.25	.525	13.34	.712	18.08
12	.7500-.067P-.2L-TS-2A	1.354	34.39	1.040	26.42	.765	19.43	.100	2.54	.804	20.42	.128	3.25	.595	15.11	.768	19.51
14	.8750-.067P-.2L-TS-2A	1.510	38.35	1.133	28.78	.859	21.82	.100	2.54	.891	22.63	.128	3.25	.650	16.51	.890	22.61
16	1.0000-.067P-.2L-TS-2A	1.620	41.15	1.242	31.55	.938	23.83	.100	2.54	1.049	26.64	.128	3.25	.795	20.19	1.015	25.78
18	1.1250-.067P-.2L-TS-2A	1.784	45.31	1.343	34.11	1.016	25.81	.100	2.54	1.148	29.16	.128	3.25	.920	23.37	1.125	28.58
20	1.2500-.067P-.2L-TS-2A	1.910	48.51	1.444	36.68	1.109	28.17	.125	3.18	1.252	31.80	.154	3.91	1.030	26.16	1.275	32.39
22	1.3750-.067P-.2L-TS-2A	2.083	52.91	1.570	39.88	1.203	30.56	.125	3.18	1.369	34.77	.154	3.91	1.130	28.70	1.400	36.56
24	1.5000-.067P-.2L-TS-2A	2.200	55.88	1.696	43.08	1.312	33.32	.125	3.18	1.509	38.33	.154	3.91	1.275	32.39	1.525	38.74

PC Tail Dimensions

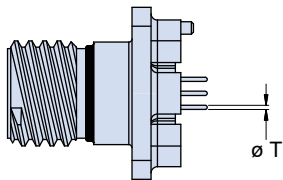

Recommended Panel Cutout

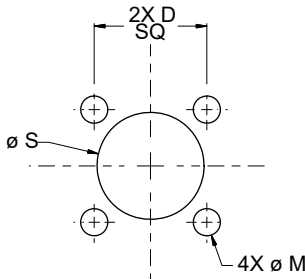

Contact Size	ϕT $\pm .002 (0.05)$	
	In.	mm.
#20	.030	0.76
#22	.020	0.51



806-026-07 Jam Nut Receptacle Dimensions

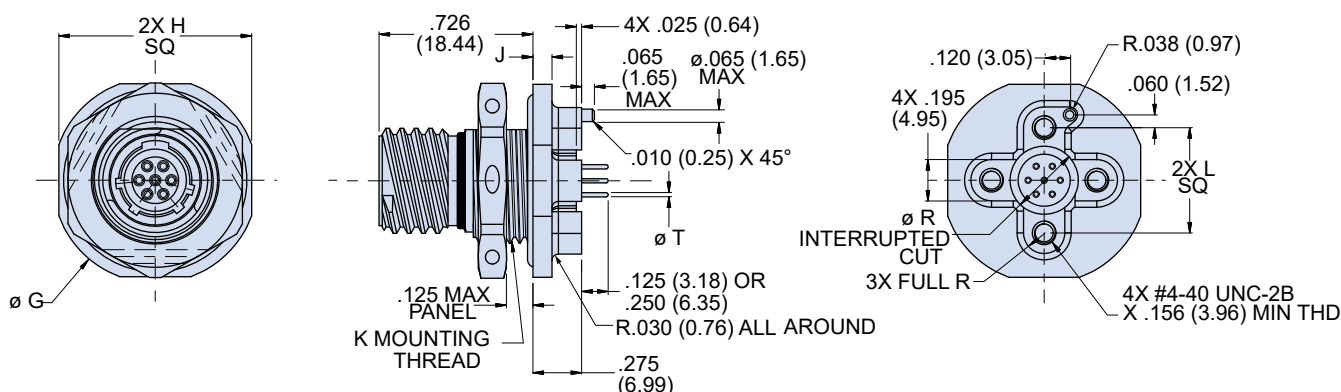

Shell Size	A Mating Thread	G Max		H Max		J Max		K Thread	L		Ø N		P		Ø R	
		In.	mm.	In.	mm.	In.	mm.		In.	mm.	In.	mm.	In.	mm.	± .015	± 0.38
8	.5000-.067P-.2L-TS-2A	.980	24.69	.920	23.37	.100	2.54	M15x1.0-6g-0.100R	.534	13.56	.601	15.27	.256	6.50	.325	8.26
9	.5625-.067P-.2L-TS-2A	1.040	26.42	.980	24.89	.100	2.54	M16x1.0-6g-0.100R	.579	14.71	.640	16.26	.287	7.29	.405	10.29
10	.6250-.067P-.2L-TS-2A	1.110	28.19	1.050	26.67	.100	2.54	M18x1.0-6g-0.100R	.679	17.25	.719	18.26	.318	8.08	.465	11.81
11	.6875-.067P-.2L-TS-2A	1.160	29.46	1.110	28.19	.100	2.54	M19x1.0-6g-0.100R	.734	18.64	.759	19.28	.350	8.89	.525	13.34
12	.7500-.067P-.2L-TS-2A	1.230	31.24	1.170	29.72	.100	2.54	M21x1.0-6g-0.100R	.804	20.42	.837	21.26	.381	9.67	.595	15.11
14	.8750-.067P-.2L-TS-2A	1.360	34.54	1.320	33.53	.100	2.54	M24x1.0-6g-0.100R	.891	22.63	.955	24.26	.443	11.25	.650	16.51
16	1.0000-.067P-.2L-TS-2A	1.515	38.48	1.444	36.68	.100	2.54	M27x1.0-6g-0.100R	1.049	26.64	1.073	27.25	.505	12.83	.795	20.19
18	1.1250-.067P-.2L-TS-2A	1.610	40.89	1.570	39.88	.100	2.54	M30x1.0-6g-0.100R	1.148	29.16	1.192	30.28	.568	14.43	.920	23.37
20	1.2500-.067P-.2L-TS-2A	1.850	46.99	1.760	44.70	.128	3.25	M34x1.0-6g-0.100R	1.252	31.80	1.349	34.26	.630	16.00	1.030	26.16
22	1.3750-.067P-.2L-TS-2A	2.010	51.05	1.913	48.59	.128	3.25	M37x1.0-6g-0.100R	1.369	34.77	1.467	37.26	.693	17.60	1.130	28.70
24	1.5000-.067P-.2L-TS-2A	2.195	55.75	2.070	52.58	.128	3.25	M41x1.0-6g-0.100R	1.509	38.33	1.624	41.25	.755	19.18	1.275	32.39

PC Tail Diameters

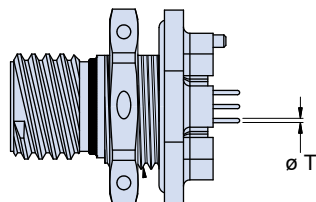

Recommended Panel Cutout

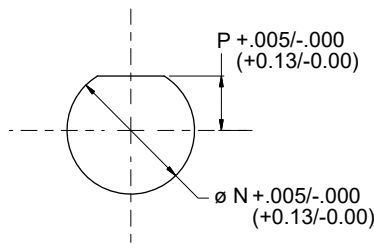

Contact Size	ϕT ± .002 (0.05)	
	In.	mm.
#20	.030	0.76
#22	.020	0.51

Mighty Mouse Mil-Aero Connectors

806-028 Lightweight Aluminum Hermetic Receptacles, PC Tail



Lightweight aluminum shell. Hermetic. Higher current rating. 806-028 aluminum hermetic receptacles are lighter in weight compared to stainless steel glass-to-metal hermetic connectors. A proprietary sealing process delivers reliable hermetic performance at extreme temperatures. Gold-plated copper alloy contacts have lower resistance and higher current rating than iron alloy contacts used in glass-to-metal hermetics. Hermeticity is $1E^{-7}$ cm³/sec at 1 ATM pressure differential. Integral standoff and threaded mounting holes provide secure attachment to rigid or flex circuits. Ultraminiature Series 806 connectors are parylene compatible, and ideal for harsh environment aerospace applications subject to severe wind, moisture and vibration.

Features

- Triple-start stub ACME mating thread
- High density #20HD and #22HD arrangements for reduced size and weight
- Aerospace-grade materials, construction
- Integral PC board standoffs
- Threaded holes for secure attachment to rigid or flex circuits
- Alignment post

Specifications

- Operating temperature: -65°C to +200°C
- Leak Rate: $1E^{-7}$ cm³/s at 1 ATM pressure differential
- Dielectric withstanding voltage
#20HD layouts: 1800 Vac
#22HD layouts: 1300 Vac
- Current rating
#20HD contacts 7.5 A
#22HD contacts 5 A
- Mating durability: 500 cycles
- Mechanical shock: EIA-364-27, 300g.
- Vibration (sine): MIL-DTL-38999M, 60g.
- Vibration (random): EIA-364-28 Condition VI, Letter J, 43.92 Grms, +200°C
- High Impact shock: MIL-S-901 Grade A
- Salt spray (dynamic): EIA-364-26, 96 hours
- Altitude immersion: EIA-364-03 75,000 feet altitude
- Indirect Lightning Strike: EIA-364-75 Type B Level 2 10kA Peak

Connector Construction

- Shell and jam nut: aluminum, electroless nickel plated
- Contacts: copper alloy, gold plating
- Sealing compound: proprietary Glenair formulation
- Dielectric inserts: high grade rigid dielectric
- Interfacial seal, peripheral seal, O-ring: fluorosilicone

How To Order						
SAMPLE PART NUMBER	806-028	-ME	8-7	P	1	A
Product	806-028 = Jam Nut Receptacle, PC Tails					
Shell Material and Finish	ME = Aluminum, Electroless Nickel					
Arrangement Number (Shell Size - Insert Arr.)	See Table 1					
Contact Type	P = Pin S = Socket					
PC Tail Length	1 = .125" (3.18 mm.) 2 = .250" (6.35 mm.)					
Polarizing Position (Table 2)	A B C D E F					

No. of Contacts	#20HD	#22HD	Arr.	Shell Size
3	●		8-3	8
4		●	8-4	8
5	●		9-5	9
7		●	8-7	8
8	●		10-8	10
10	●		11-10	11
11		●	9-11	9
15		●	10-15	10
15	●		12-15	12
19		●	11-19	11
20	●		14-20	14
26		●	12-26	12
31	●		16-31	16
39		●	14-39	14
41	●		18-41	18
55	●		20-55	20
60		●	16-60	16
69	●		22-69	22
85		●	18-85	18
92	●		24-92	24
110		●	20-110	20
140		●	22-140	22
186		●	24-186	24

Position	A°	B°	C°	D°
A	105	140	215	265
B	102	170	248	305
C	80	150	230	295
D	68	140	205	275
E	64	155	234	304
F	72	120	200	298

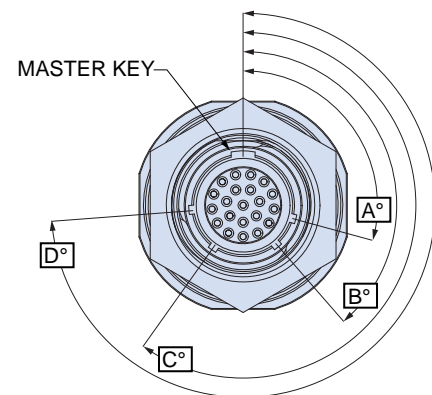

Mighty Mouse Mil-Aero Connectors

806-028 Lightweight Aluminum Hermetic Receptacles, PC Tail

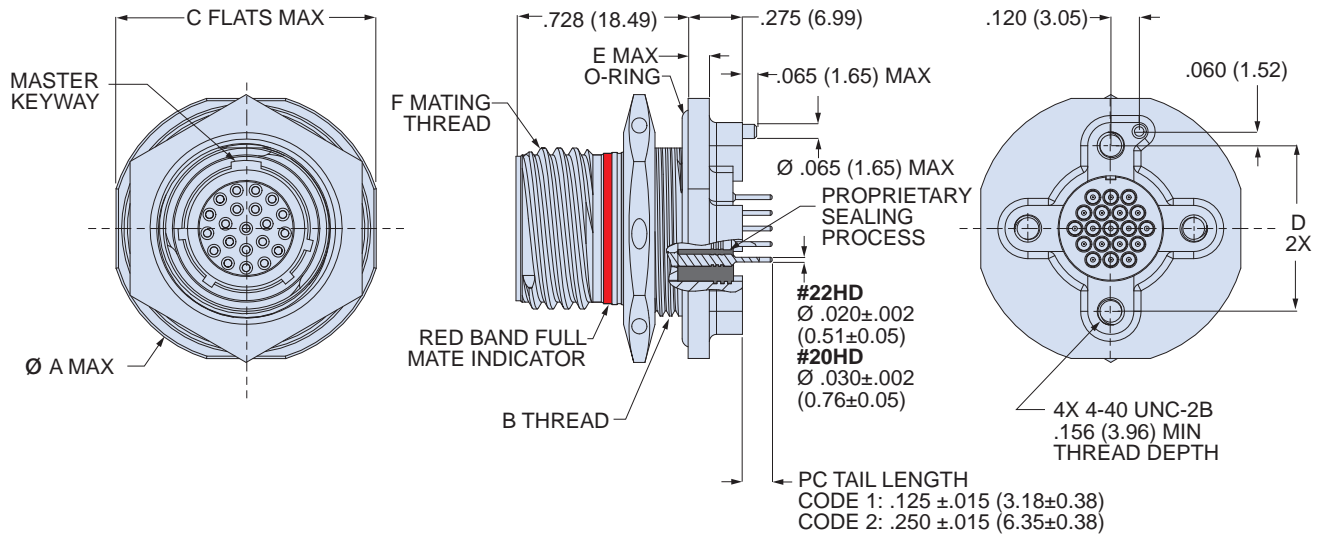

806-028 Receptacle Dimensions

Shell Size	ϕA Max		B Thread	C Max		D		E Max		F Mating Thread
	In.	mm.		In.	mm.	In.	mm.	In.	mm.	
8	.980	24.69	M15x1.0-6g-0.100R	.920	23.37	.534	13.56	.100	2.54	.5000-.067P-2L-TS-2A
9	1.040	26.42	M16x1.0-6g-0.100R	.980	24.89	.579	14.71	.100	2.54	.5625-.067P-2L-TS-2A
10	1.110	28.19	M18x1.0-6g-0.100R	1.050	26.67	.679	17.25	.100	2.54	.6250-.067P-2L-TS-2A
11	1.160	29.46	M19x1.0-6g-0.100R	1.110	28.19	.734	18.64	.100	2.54	.6875-.067P-2L-TS-2A
12	1.230	31.24	M21x1.0-6g-0.100R	1.170	29.72	.804	20.42	.100	2.54	.7500-.067P-2L-TS-2A
14	1.360	34.54	M24x1.0-6g-0.100R	1.320	33.53	.891	22.63	.100	2.54	.8750-.067P-2L-TS-2A
16	1.515	38.48	M27x1.0-6g-0.100R	1.444	36.68	1.049	26.64	.100	2.54	1.0000-.067P-2L-TS-2A
18	1.610	40.89	M30x1.0-6g-0.100R	1.570	39.88	1.148	29.16	.100	2.54	1.1250-.067P-2L-TS-2A
20	1.850	46.99	M34x1.0-6g-0.100R	1.760	44.70	1.252	31.80	.128	3.25	1.2500-.067P-2L-TS-2A
22	2.010	51.05	M37x1.0-6g-0.100R	1.913	48.59	1.369	34.77	.128	3.25	1.3750-.067P-2L-TS-2A
24	2.195	55.75	M41x1.0-6g-0.100R	2.070	52.58	1.509	38.33	.128	3.25	1.5000-.067P-2L-TS-2A

806-028 Jam Nut D-Hole Dimensions

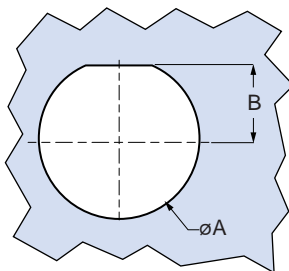

Shell Size	ϕA		B	
	In.	mm.	In.	mm.
8	+0.005/-0.00	+0.13/-0.00	+0.005/-0.00	6.50
9	.640	16.26	.287	7.29
10	.719	18.26	.318	8.08
11	.759	19.28	.350	8.89
12	.837	21.26	.381	9.67
14	.955	24.26	.443	11.25
16	1.073	27.25	.505	12.83
18	1.192	30.28	.568	14.43
20	1.349	34.26	.630	16.00
22	1.467	37.26	.693	17.60
24	1.624	41.25	.755	19.18

Series 806

Mighty Mouse Mil-Aero Connectors

240-806 Filtered Receptacles, Jam Nut



Features

- Ceramic planar filter array
- Solder cup or PC tail contacts
- High density #20HD and #22HD arrangements for reduced size and weight
- Aerospace-grade materials, construction

Specifications

- Operating temperature: -55°C to +125°C
- Dielectric withstanding voltage: 300 VDC
- Current rating
#20HD contacts 5 A max.
#22HD contacts 3 A max.
- Mating durability: 500 cycles

Connector Construction

- Shell, jam nut: aluminum or stainless steel
- Contacts: copper alloy, gold plated
- Seals: fluorosilicone
- Insulator: high grade rigid dielectric

Ceramic planar array C and Pi filters. Jam nut panel mounting. PC tail or solder cup contacts. 240-806 filtered receptacles save size and weight compared to traditional aerospace-grade circular connectors. These high performance connectors are suitable for areas subject to high vibration and moisture. -55°C to +125°C.

How To Order	
SAMPLE PART NUMBER	240-806 -07 ME 8-7 PS C B A
Product	240-806 = Filtered Receptacle
Mounting Type	07 = Jam Nut with Solder Cup Contacts and NanoBand Platform 08 = Jam Nut with PC Tail Contacts*
Shell Material and Finish	ME = Aluminum, Electroless Nickel MT = Aluminum, Ni/PTFE ZR = Aluminum, Black Zinc-Nickel NF = Aluminum, Olive Drab Cadmium Z1 = Stainless Steel, Passivated
Arrangement Number (Shell Size - Insert Arr.)	See Table 1
Contact Type	PP = Pin, PC Tail (mounting type 08 only) PS = Pin, Solder Cup (mounting type 07 only) SP = Socket, PC Tail (mounting type 08 only) SS = Socket, Solder Cup (mounting type 07 only)
Filter Type	P = Pi Filter C = C Filter L = L - C Filter M = C - L Filter
Capacitance Class (Table 3)	A B C D E F G J
Polarizing Position (Table 2)	A B C D E F

* PC-tail contact versions are parylene-compatible

No. of Contacts	#20HD	#22HD	Arr.	Shell Size
3	●		8-3	8
4		●	8-4	8
5	●		9-5	9
7		●	8-7	8
8	●		10-8	10
10	●		11-10	11
11		●	9-11	9
15		●	10-15	10
15	●		12-15	12
19		●	11-19	11
20	●		14-20	14
26		●	12-26	12
31	●		16-31	16
39		●	14-39	14
41	●		18-41	18
55	●		20-55	20
60		●	16-60	16
69	●		22-69	22
85		●	18-85	18
92	●		24-92	24
110		●	20-110	20
140		●	22-140	22
186		●	24-186	24

Position	A°	B°	C°	D°
A	105	140	215	265
B	102	170	248	305
C	80	150	230	295
D	68	140	205	275
E	64	155	234	304
F	72	120	200	298

Class	Capacitance Range (pF)	
	P (Pi-Section)	C, L, M (C, L-C, C-L)
A	38,000 - 56,000	19,000 - 28,000
B	32,000 - 45,000	16,000 - 22,500
C	18,000 - 33,000	9,000 - 16,500
D	8,000 - 12,000	4,000 - 6,000
E	3,300 - 5,000	1,650 - 2,500
F	800 - 1,300	400 - 650
G	400 - 600	200 - 300
J	70 - 120	35 - 60

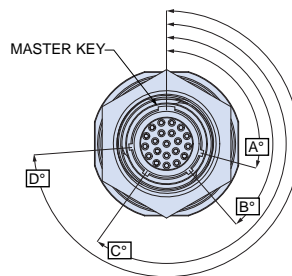

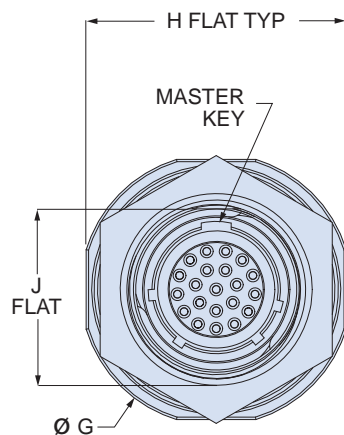

Contact Size	ØU	
	±.002 (0.05) In.	mm.
#20	.026	0.66
#22	.020	0.51

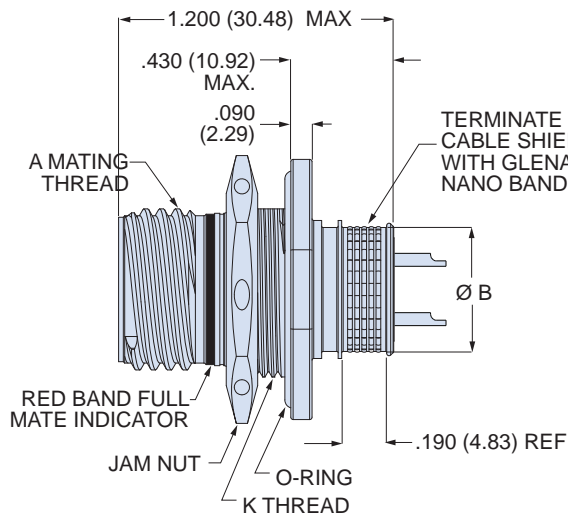

SHELL STYLE 07
JAM NUT RECEPTACLE
NANOBAND PLATFORM, SOLDER CUP CONTACTS

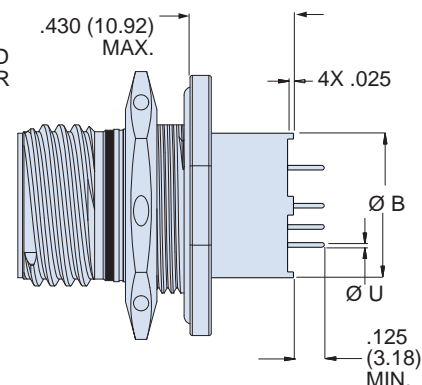

SHELL STYLE 08
JAM NUT RECEPTACLE
PCB CONTACTS

240-806 Receptacle Dimensions

Shell Size	A Mating Thread	ØB		ØG Max		H Max		J Flat		K Thd x1.0-6g-0.100R
		In.	mm.	In.	mm.	In.	mm.	In.	mm.	
8	.5000-.067P-.2L-TS-2A	.424	10.77	.980	24.69	.920	23.37	.536	13.61	M15
9	.5625-.067P-.2L-TS-2A	.464	11.79	1.040	26.42	.980	24.89	.587	14.91	M16
10	.6250-.067P-.2L-TS-2A	.584	14.83	1.110	28.19	1.050	26.67	.658	16.71	M18
11	.6875-.067P-.2L-TS-2A	.619	15.72	1.160	29.46	1.110	28.19	.709	18.01	M19
12	.7500-.067P-.2L-TS-2A	.699	17.75	1.230	31.24	1.170	29.72	.779	19.79	M21
14	.8750-.067P-.2L-TS-2A	.784	19.91	1.360	34.54	1.320	33.53	.900	22.86	M24
16	1.0000-.067P-.2L-TS-2A	.919	23.34	1.515	38.48	1.444	36.68	1.022	25.96	M27
18	1.1250-.067P-.2L-TS-2A	1.014	25.76	1.610	40.89	1.570	39.88	1.144	29.06	M30
20	1.2500-.067P-.2L-TS-2A	1.150	29.21	1.850	46.99	1.760	44.70	1.285	32.64	M34
22	1.3750-.067P-.2L-TS-2A	1.254	31.85	2.010	51.05	1.913	48.59	1.406	35.71	M37
24	1.5000-.067P-.2L-TS-2A	1.394	35.41	2.195	55.75	2.070	52.58	1.547	39.29	M41

Table 4 Filter Types

C	Single capacitor with low self inductance	
Pi	Dual capacitors with a single inductive element positioned between	
L-C	Single capacitor and an inductive element	
C-L	Single capacitor and an inductive element	

240-806 Jam Nut D-Hole Dimensions

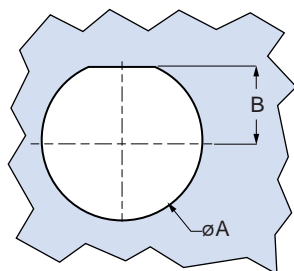

Shell Size	ØA		B	
	In.	mm.	In.	mm.
8	+.005/-0.00	+0.13/-0.00	+.005/-0.00	+0.13/-0.00
9	.601	15.27	.256	6.50
10	.640	16.26	.287	7.29
11	.719	18.26	.318	8.08
12	.759	19.28	.350	8.89
14	.837	21.26	.381	9.67
16	.955	24.26	.443	11.25
18	1.073	27.25	.505	12.83
20	1.192	30.28	.568	14.43
22	1.349	34.26	.630	16.00
24	1.467	37.26	.693	17.60
24	1.624	41.25	.755	19.18



Features

- Ceramic planar filter array
- PC tail contacts
- High density #20HD and #22HD arrangements for reduced size and weight
- Aerospace-grade materials, construction

Specifications

- Operating temperature: -55°C to +125°C
- Dielectric withstanding voltage: 300 VDC
- Current rating
#20HD contacts 5 A max.
#22HD contacts 3 A max.
- Mating durability: 500 cycles

Connector Construction

- Shell, jam nut: aluminum or stainless steel
- Contacts: copper alloy, gold plated
- Seals: fluorosilicone
- Insulator: high grade rigid dielectric

Ceramic planar array C and Pi filters. Jam nut panel mounting. PC tail with board mounting flange. 240-806-21 filtered receptacles save size and weight compared to legacy aerospace-grade EMI/RFI filter connectors. These high-performance, parylene-compatible connectors are suitable for areas subject to high vibration and moisture. Size 20HD and size 22HD contacts. Board mounting flange has threaded standoffs and orientation post. -55°C to +125°C Equipped with low-profile threaded standoff.

How To Order		ME	8-7	PP	P	C	A
SAMPLE PART NUMBER	240-806-21						
Product	240-806-21 = Filtered Receptacle, Board Mount						
Shell Material and Finish	ME = Aluminum, Electroless Nickel MT = Aluminum, Ni/PTFE ZR = Aluminum, Black Zinc-Nickel NF = Aluminum, Olive Drab Cadmium Z1 = Stainless Steel, Passivated						
Arrangement Number (Shell Size - Insert Arr.)	See Table 1						
Contact Type	PP = Pin, PC Tail SP = Socket, PC Tail						
Filter Type	P = Pi Filter C = C Filter L = L - C Filter M = C - L Filter						
Capacitance Class (Table 3)	A B C D E F G J						
Polarizing Position (Table 2)	A B C D E F						

No. of Contacts	#20HD	#22HD	Arr.	Shell Size
3	●		8-3	8
4		●	8-4	8
5	●		9-5	9
7		●	8-7	8
8	●		10-8	10
10	●		11-10	11
11		●	9-11	9
15		●	10-15	10
15	●		12-15	12
19		●	11-19	11
20	●		14-20	14
26		●	12-26	12
31	●		16-31	16
39		●	14-39	14
41	●		18-41	18
55	●		20-55	20
60		●	16-60	16
69	●		22-69	22
85		●	18-85	18
92	●		24-92	24
110		●	20-110	20
140		●	22-140	22
186		●	24-186	24

Position	A°	B°	C°	D°
A	105	140	215	265
B	102	170	248	305
C	80	150	230	295
D	68	140	205	275
E	64	155	234	304
F	72	120	200	298

Class	Capacitance Range (pF)	
	P (Pi-Section)	C, L, M (C, L-C, C-L)
A	38,000 - 56,000	19,000 - 28,000
B	32,000 - 45,000	16,000 - 22,500
C	18,000 - 33,000	9,000 - 16,500
D	8,000 - 12,000	4,000 - 6,000
E	3,300 - 5,000	1,650 - 2,500
F	800 - 1,300	400 - 650
G	400 - 600	200 - 300
J	70 - 120	35 - 60

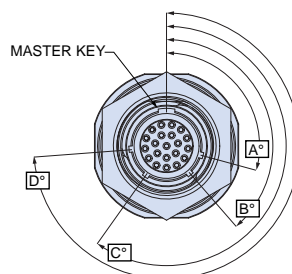

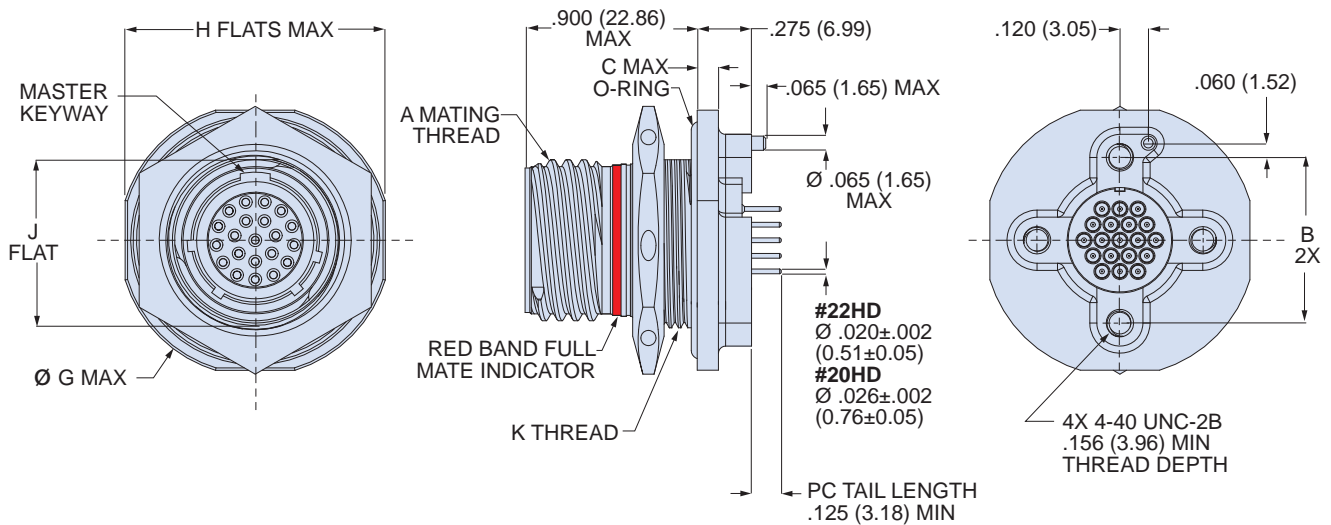

240-806-21 Receptacle Dimensions

Shell Size	A Mating Thread	B		C Max		øG Max		H Max		J Flat		K Thd x1.0-6g-0.100R
		In.	mm.	In.	mm.	In.	mm.	In.	mm.	In.	mm.	
8	.5000-.067P-.2L-TS-2A	.534	13.56	.100	2.54	.980	24.69	.920	23.37	.536	13.61	M15
9	.5625-.067P-.2L-TS-2A	.579	14.71	.100	2.54	1.040	26.42	.980	24.89	.587	14.91	M16
10	.6250-.067P-.2L-TS-2A	.679	17.25	.100	2.54	1.110	28.19	1.050	26.67	.658	16.71	M18
11	.6875-.067P-.2L-TS-2A	.734	18.64	.100	2.54	1.160	29.46	1.110	28.19	.709	18.01	M19
12	.7500-.067P-.2L-TS-2A	.804	20.42	.100	2.54	1.230	31.24	1.170	29.72	.779	19.79	M21
14	.8750-.067P-.2L-TS-2A	.891	22.63	.100	2.54	1.360	34.54	1.320	33.53	.900	22.86	M24
16	1.0000-.067P-.2L-TS-2A	1.049	26.64	.100	2.54	1.515	38.48	1.444	36.68	1.022	25.96	M27
18	1.1250-.067P-.2L-TS-2A	1.148	29.16	.100	2.54	1.610	40.89	1.570	39.88	1.144	29.06	M30
20	1.2500-.067P-.2L-TS-2A	1.252	31.80	.128	3.25	1.850	46.99	1.760	44.70	1.285	32.64	M34
22	1.3750-.067P-.2L-TS-2A	1.369	34.77	.128	3.25	2.010	51.05	1.913	48.59	1.406	35.71	M37
24	1.5000-.067P-.2L-TS-2A	1.509	38.33	.128	3.25	2.195	55.75	2.070	52.58	1.547	39.29	M41

240-806-21 Jam Nut D-Hole Dimensions

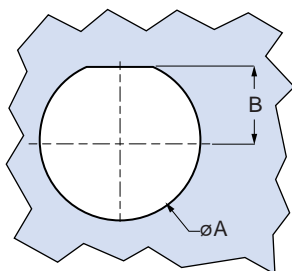

Shell Size	øA		B	
	In. +0.005/-0.00	mm. +0.13/-0.00	In. +0.005/-0.00	mm. +0.13/-0.00
8	.601	15.27	.256	6.50
9	.640	16.26	.287	7.29
10	.719	18.26	.318	8.08
11	.759	19.28	.350	8.89
12	.837	21.26	.381	9.67
14	.955	24.26	.443	11.25
16	1.073	27.25	.505	12.83
18	1.192	30.28	.568	14.43
20	1.349	34.26	.630	16.00
22	1.467	37.26	.693	17.60
24	1.624	41.25	.755	19.18

Table 4
Filter Types

C	Single capacitor with low self inductance
Pi	Dual capacitors with a single inductive element positioned between
L-C	Single capacitor and an inductive element
C-L	Single capacitor and an inductive element



Single or multi mode. Ceramic ferrule. 0.5 dB loss. Size 20HD fiber optic termini are compatible with Series 806 connectors with size 20HD contact arrangements. These snap-in, rear release termini feature precision ceramic ferrules for accurate fiber alignment. Typical insertion loss 0.5 dB. Fits 50/125 and 62.5/125 multi mode and 9/125 single mode fiber.

#20HD Fiber Optic Termini for Series 806 Connectors				
Termini Type	Optical Fiber Type	Part Number	ØA Ferrule Hole	Fiber Size Core/Cladding
Pin	Single Mode	181-134-1255	125.5 microns	9/125
Pin	Multi Mode	181-134-126	126.0 microns	50/125, 62.5/125
Socket	Single Mode	181-135-1255	125.5 microns	9/125
Socket	Multi Mode	181-135-126	126.0 microns	50/125, 62.5/125

Specifications

- Operating temperature: -55°C to +125°C
Temperature rating depends on the cable and epoxy used.
- Termination method: epoxy/polish
- Mating durability: 500 cycles
- Random vibration: 49.5 Grms, EIA-364-28 Test Condition V. Maximum optical discontinuity 0.5 dB, 50 microseconds.
- Mechanical shock: 300 G, TIA-455-14 Test Condition D. Maximum optical discontinuity 0.5 dB, 50 microseconds.

Construction

- Ferrule, alignment sleeve: zirconia ceramic
- Body, shroud: copper/nickel/zinc alloy
- Spring (socket, not shown): stainless steel, passivated
- Protective cover (socket): copper alloy, nickel plated

Termination Tools

- Polishing pucks

Puck Style	Type	Tool PN
Pin	dry polish	182-056P
	wet polish	182-056PW
Socket	dry polish	182-056S
	wet polish	182-056SW

Assembly Tools

- Plastic insertion/extraction tool: 809-203D
- Metal insertion/extraction tool: 809-203

#20HD Pin Terminus 181-134

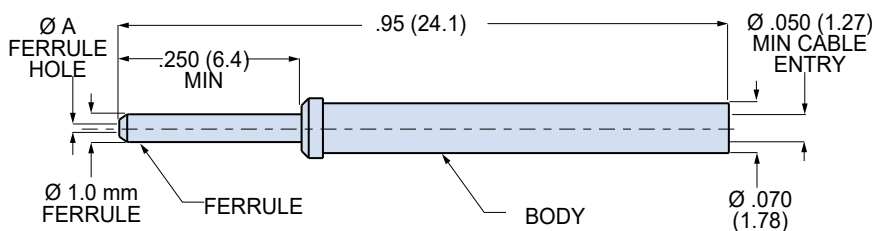

#20HD Socket Terminus 181-135

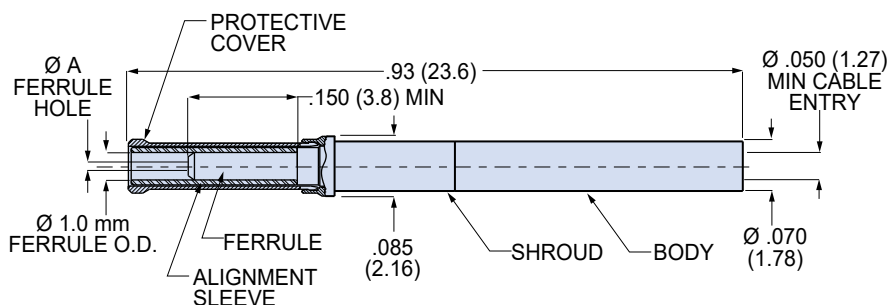



Military grade. Heavy gold plating. High-density size #22HD contacts accept #22 to #30 AWG wire. Compatible with Series 806 connectors with size 22HD contact cavities. Crimp termination. Contacts are bulk packaged.

#22HD Contacts for Series 806 Connectors						
Contact Type	Wire Size AWG	Part Number	A		Color Band	
			In.	mm.		
Pin	#22 – #28	850-094-1	.0335-.0355	0.851-0.902	(none)	
Pin	#26 – #30	850-094-2	.0229-.0245	0.582-0.622	Blue	
Socket	#22 – #28	850-095-1	.0335-.0355	0.851-0.902	(none)	
Socket	#26 – #30	850-095-2	.0229-.0245	0.582-0.622	Blue	

Specifications

- Operating temperature: -65°C to +200°C
- Current rating 5 A
- Crimp Tensile Strength:

Wire Size	Axial Load (lbs)
22	12
24	8
26	5
28	3
30	1.5

- Contact Resistance: silver-plated wire, 25°C (AS39029 Table 5)

Wire Size	Test Current Amperes	Max. mV Drop
22	5	73
24	3	45
26	2	52
28	1.5	54
30	1	60

- Meets performance requirements of SAE AS39029/121 and /122

Construction

- Copper alloy, 50 microinches gold over nickel plating
- Socket Hood: stainless steel, passivated

Termination Tools

Contact Part Number	Positioner	Crimp Tool
850-094-1	859-147	809-015
850-094-2	859-148	
850-095-1	809-005	
850-095-2	809-057	

Assembly Tools

- Insertion/Extraction Tool: 859-163

#22HD Socket Contact 850-095

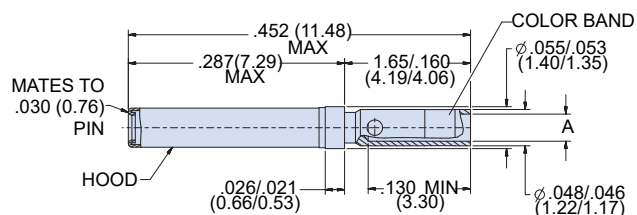

#22HD Pin Contact 850-094

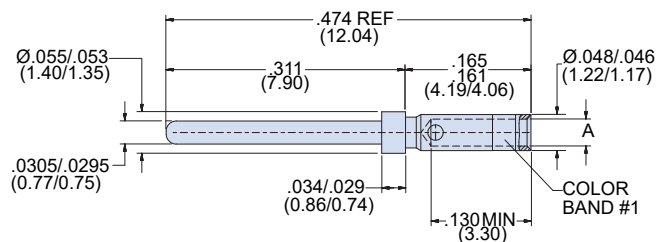

Wire Strip Length

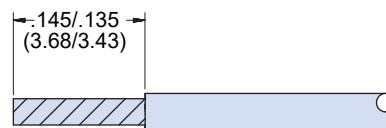

RECOMMENDED WIRE STRIP LENGTH



Military grade. Heavy gold plating. High-density size #22HD contacts accept #20 AWG wire. Compatible with Series 806 connectors with size 22HD contact cavities. Crimp termination, non-removable. Contacts are bulk packaged.

#22HD for #20AWG Wire	
Contact	Part Number
Pin	809-442
Socket	809-443

Specifications

- Maximum engagement force 8.0 oz. (MS33197-23Y1 Pin)
- Maximum separation force 0.5 oz (MS3197-23X1 pin)
- Current rating: 5 AMP max.
- Crimp tensile strength:

Wire Size	Axial Load (lbs)
20	20
22	12
24	8

- Contact millivolt drop: 70 millivolts max at 5 AMPs, 25°C

Construction

- Copper alloy, 50 microinches gold over nickel underplating
- Socket hood: stainless steel, passivated

Termination Tools

Contact Part Number	Positioner	Crimp Tool
809-443	809-206 or 809-301	809-015
809-442		

Intended Use

- For use with Series 806 connectors
- Cannot be removed after installation
- Due to diameter of 20AWG wire, the arrangement may not be able to accept a full complement of 20AWG wire assemblies. It is recommended that 20AWG wire assemblies be utilized in alternate cavities.

#22HD Socket Contact 809-443

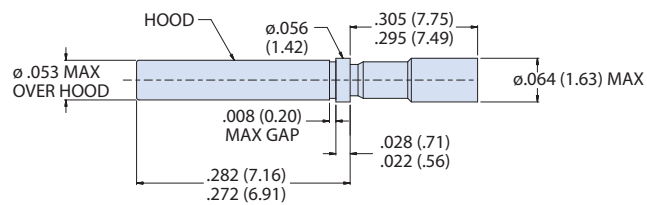

#22HD Pin Contact 809-442

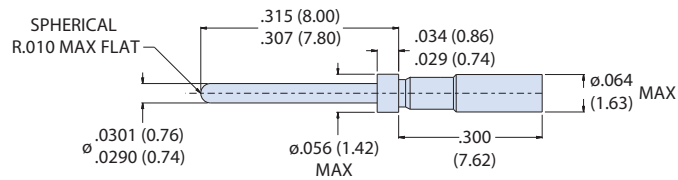

Wire Strip Length

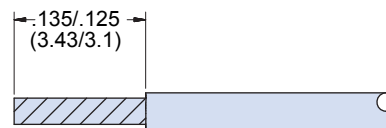

RECOMMENDED WIRE STRIP LENGTH



Miniature Adjustable Crimp Tool



Standard M22520/2-01 crimper. Use with size #20HD and #22HD Series 806 contacts. Requires positioner, ordered separately. These crimp tools perform precision eight indent crimps for gas-tight wire terminations and excellent tensile strength. Adjustment wheel has 8 settings. Ratchet mechanism prevents improper crimps. Use with bayonet-type positioners. Length is 6.75 inches, weight is approx. 10 oz.

Part Number	Military Part Number	Daniels* Part Number
809-015	M22520/2-01	AFM8

* Daniels Manufacturing Corporation, Orlando, FL. www.dmctools.com.

Positioners for use with Crimp Tool



These bayonet-type positioners hold contacts at correct height for crimping with 809-015 crimp tool. Data plate shows correct crimp tool setting based on wire size.

Contact Type	Ref. Contact Part Number	Positioner
#20HD Pin	809-204	809-206
#20HD Socket	809-205	809-206
#22HD Pin	850-094-1	859-147
#22HD Pin, Small Dia. Wire	850-094-2	859-148
#22HD Socket	850-095-1	809-005
#22HD Socket, Small Dia. Wire	850-095-2	809-057

Insertion/Extraction Tool for #20HD Contacts



Insertion/Extraction Tool for #20HD Contacts. This tool features molded plastic grips and sturdy stainless steel or thermoplastic tips.

Contact Size	Tip Material	Color	Insertion/Extraction Tool
#20HD	Stainless Steel	Green (Ins.)/White (Ext.)	809-203
#20HD	Thermoplastic	Green (Ins.)/Blue (Ext)	809-203D

Insertion/Extraction Tools for #22HD Contacts



Insertion/extraction tool for #22HD contacts. Features molded plastic grips and sturdy stainless steel tips. White/yellow molded handle.

Type	Part Number
Insertion/Extraction	859-163 <i>(M81969/1-05)</i>



Grommet sealing plugs

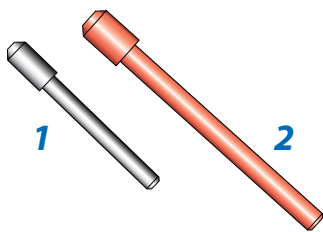

Grommet sealing plugs are used to seal unwired contact cavities. After installing unwired contacts into unused cavities, insert knob end of sealing plug into grommet until it bottoms against the unwired contact. Weight- and cost-saving thermoplastic alternative to metal contacts.

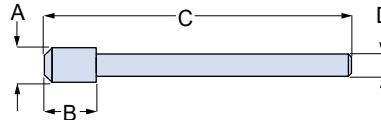

Fig.	Size	Color	Part Number	Military Part Number	A Ref.		B Ref.		C Ref.		D Ref.	
					in.	mm.	in.	mm.	in.	mm.	in.	mm.
1	#22	Black	859-021	MS27488-22-2	.062	1.57	.125	3.18	.469	11.91	.042	1.07
2	#20	Red	859-012	MS27488-20-2	.085	2.16	.125	3.18	.780	19.81	.053	1.35

**Nano Band-Master ATS®
Shield Termination System**



Fast, cost-effective shield termination. Attach cable shields to Series 806 connectors with low profile, lightweight Nano **Band-Master**® stainless steel straps. The **Band-Master**® system offers fast termination and the flexibility to handle a wide range of parts with just one band size. Approved for aerospace and defense, these straps have successfully passed rigorous shock, vibration and environmental testing.

1 Nano Band Installation Tool. Use with .075" (1.90 mm) wide nano bands. 6.75 inches (172 mm.) length, 1.2 pounds (0.6 Kg.). Tool is factory-calibrated at 50 ± 3 pounds (222.4 N ± 13.3). LED calibration counter.

Description	Part Number
Nano Band Installation Tool	601-108

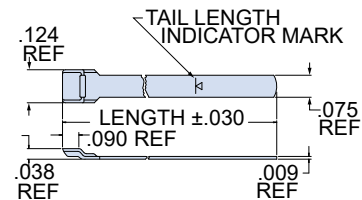

2 Nano Band, .075" (1.90 mm) wide. Available in three lengths, flat or pre-coiled. 300 series stainless steel, passivated.

Length		Part Number		Accommodates Diameter	
in.	mm.	Flat	Pre-Coiled	in.	mm.
6.000	152.40	601-500	601-501	.60	15.24
9.000	228.60	601-504	601-505	.94	23.88
14.000	355.60	601-508	601-509	1.88	47.75

Contact Glenair or visit our website (glenair.com/bandmaster) to view our complete line of **Band-Master ATS**® products, including pneumatic tools for high volume production and calibration kits.

O-rings for Series 806 Jam Nut Receptacles

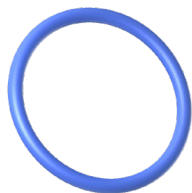

Replace damaged O-rings with standard mil spec fluorosilicone O-rings or, for added EMI protection, select O-rings made of silver-plated aluminum-filled silicone (MIL-DTL-83528 Type B) or passivated silver-plated aluminum-filled fluorosilicone (MIL-DTL-83528 Type D).

Shell Size	Size (ID x W)	Fluorosilicone (Non-conductive)	MIL-DTL-83528	MIL-DTL-83528
			Type B Conductive Silicone	Type D Conductive Fluorosilicone
8	.676 x .070	M25988/3-017	249-003-806-08-B	249-003-806-08-C
9	.739 x .070	M25988/3-018	249-003-806-09-B	249-003-806-09-C
10	.801 x .070	M25988/3-019	249-003-806-10-B	249-003-806-10-C
11	.864 x .070	M25988/3-020	249-003-806-11-B	249-003-806-11-C
12	.926 x .070	M25988/3-021	249-003-806-12-B	249-003-806-12-C
14	1.051 x .070	M25988/3-023	249-003-806-14-B	249-003-806-14-C
16	1.176 x .070	M25988/3-025	249-003-806-16-B	249-003-806-16-C
18	1.301 x .070	M25988/3-027	249-003-806-18-B	249-003-806-18-C
20	1.424 x .103	M25988/3-127	249-003-806-20-B	249-003-806-20-C
22	1.549 x .103	M25988/3-129	249-003-806-22-B	249-003-806-22-C
24	1.737 x .103	M25988/3-132	249-003-806-24-B	249-003-806-24-C



**Panel Gaskets for Series 806
Square Flange Receptacles**

These flange gaskets provide sealing between square flange receptacles and the mounting panel. Choose fluorosilicone, Viton®, silver-plated aluminum-filled silicone (MIL-DTL-83528 Type B) or passivated silver-plated aluminum-filled fluorosilicone (MIL-DTL-83528 Type D).

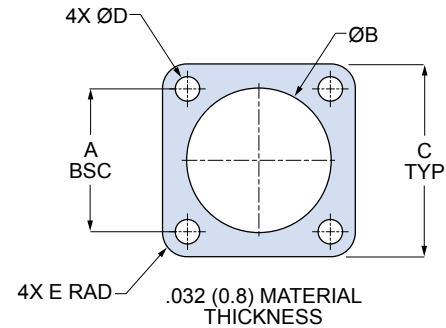
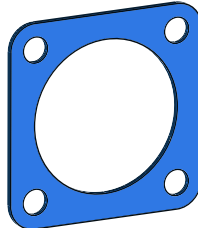

Shell Size	Non-Conductive Elastomer		Conductive Elastomer		DIMENSIONS									
	Fluorosilicone	Viton®	Silicone MIL-DTL-83528 Type B	Fluorosilicone MIL-DTL-83528 Type D	A BSC		Ø B		C		D		E RAD	
					In.	mm.	In.	mm.	In.	mm.	In.	mm.	In.	mm.
8	930-017F-1	930-017V-1	930-017C-1	930-017X-1	.531	13.49	.515	13.08	.815	20.70	.131	3.33	.130	3.30
9	930-017F-2	930-017V-2	930-017C-2	930-017X-2	.594	15.09	.582	14.78	.878	22.30	.131	3.33	.130	3.30
10	930-017F-3	930-017V-3	930-017C-3	930-017X-3	.625	15.88	.650	16.51	.906	23.01	.131	3.33	.130	3.30
11	930-017F-4	930-017V-4	930-017C-4	930-017X-4	.670	17.02	.717	18.21	.953	24.21	.131	3.33	.130	3.30
12	930-017F-5	930-017V-5	930-017C-5	930-017X-5	.765	19.43	.773	19.63	1.031	26.19	.131	3.33	.130	3.30
14	930-017F-6	930-017V-6	930-017C-6	930-017X-6	.859	21.82	.895	22.73	1.126	28.60	.131	3.33	.090	2.29
16	930-017F-7	930-017V-7	930-017C-7	930-017X-7	.938	23.83	1.020	25.91	1.220	30.99	.157	3.99	.130	3.30
18	930-017F-8	930-017V-8	930-017C-8	930-017X-8	1.016	25.81	1.130	28.70	1.311	33.30	.157	3.99	.090	2.29
20	930-017F-9	930-017V-9	930-017C-9	930-017X-9	1.109	28.17	1.280	32.51	1.437	36.50	.157	3.99	.130	3.30
22	930-017F-10	930-017V-10	930-017C-10	930-017X-10	1.203	30.56	1.405	35.69	1.563	39.70	.157	3.99	.130	3.30
24	930-017F-11	930-017V-11	930-017C-11	930-017X-11	1.312	33.32	1.530	38.86	1.689	42.90	.157	3.99	.180	4.57

**Series 806 Connector
Holding Tools**

These tools are used to keep connectors stationary while tightening backshells. Nickel-plated alloy steel. Tool has ¼ inch square socket drive.



Plug holding tool

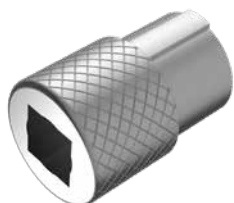

Receptacle holding tool

Shell Size	Plug Holding Tool	Receptacle Holding Tool	Recommended Backshell Tightening Torque In-Lbs.	
			Min.	Max.
8	600-221-08P	600-221-08R	20	25
9	600-221-09P	600-221-09R	20	25
10	600-221-10P	600-221-10R	20	30
11	600-221-11P	600-221-11R	20	30
12	600-221-12P	600-221-12R	25	35
14	600-221-14P	600-221-14R	25	35
16	600-221-16P	600-221-16R	30	40
18	600-221-18P	600-221-18R	30	40
20	600-221-20P	600-221-20R	35	45
22	600-221-22P	600-221-22R	35	45
24	600-221-24P	600-221-24R	35	45



**Series 806 Connector
Spanner Tools**

Use these tools to tighten Series 80 jam nuts. 3/8" square drive for use with torque wrenches. Heat treated steel, nickel plated.



Shell Size	Socket Drive	Recommended Backshell Tightening Torque In-Lbs.		Jam Nut Thread Size Reference
		Min.	Max.	
7	600-246-7	20	25	M13 x 1.0-6H
8	600-246-8	20	25	M15 x 1.0-6H
9	600-246-9	20	25	M16 x 1.0-6H
10	600-246-10	25	30	M18 x 1.0-6H
11	600-246-11	25	30	M19 x 1.0-6H
12	600-246-12	25	30	M21 x 1.0-6H
14	600-246-14	25	30	M24 x 1.0-6H
16	600-246-16	25	30	M27 x 1.0-6H
18	600-246-18	25	30	M30 x 1.0-6H
20	600-246-20	25	30	M34 x 1.0-6H
22	600-246-22	25	30	M37 x 1.0-6H
24	600-246-24	25	30	M41 x 1.0-6H
All Shell Sizes	600-246-KIT	25	30	All Listed Above

**Series 806 Low Profile
Jam-nut**

Replace lost or damaged Series 80 low profile jam nuts. Use Glenair spanner tool 600-246.

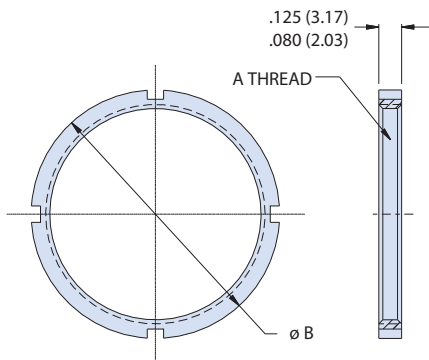

Dash No.	Thread A	B ±.020 Dia.	Spanner Tool
7	M13 x 1.0-6H	.705 (17.91)	600-246-7
8	M15 x 1.0-6H	.766 (19.46)	600-246-8
9	M16 x 1.0-6H	.829 (21.06)	600-246-9
10	M18 x 1.0-6H	.891 (22.63)	600-246-10
11	M19 x 1.0-6H	.954 (24.23)	600-246-11
12	M21 x 1.0-6H	1.016 (25.81)	600-246-12
14	M24 x 1.0-6H	1.149 (29.18)	600-246-14
16	M27 x 1.0-6H	1.272 (32.31)	600-246-16
18	M30 x 1.0-6H	1.397 (35.48)	600-246-18
20	M34 x 1.0-6H	1.567 (39.80)	600-246-20
22	M37 x 1.0-6H	1.690 (42.93)	600-246-22
24	M41 x 1.0-6H	1.880 (47.75)	600-246-24

Class	Material	Finish Description
ME	Aluminum	Electroless nickel
MT		Nickel-PTFE
NF		Olive drab cadmium over electroless nickel finish
ZR		Zinc nickel black over electroless nickel. RoHS compliant
Z1	Stainless	Passivate
ZL	Steel	Electrodeposited nickel

Part Number Development

809-444	-ME	8
Product Series and Basic Number	Material and Finish See Table II	Dash Number, See Table I

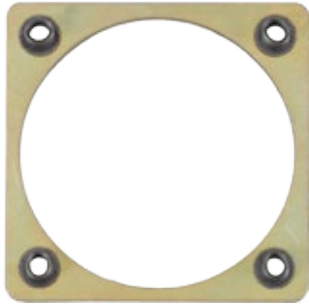

1 Full perimeter nut plate. Assemble over wires before connector termination. Shown with epoxy primer coating.



2 3/4 perimeter nut plate for installation on pre-wired assemblies. Shown with epoxy primer coating.

Nut plates speed up connector installation and eliminate dropped hardware in hard-to-reach locations. For use with Series 806 square flange panel mount connectors. Two styles: full perimeter and 3/4 perimeter. Install full perimeter plate over wires before terminating the connector. 3/4 perimeter version can be installed on wired connectors. Aluminum plate with self-locking stainless steel female clinch nuts. Plate is coated with chem film per MIL-DTL-5541 Class 1A, or, for maximum corrosion protection choose epoxy primer coating.

How To Order					
SAMPLE PART NUMBER	480-003	E	12	B	
Product	480-003 = Nut Plate for Series 806 Receptacles				
Finish	E = Chem film EAP = Epoxy primer coating				
Shell Size	8 9 10 11 12 14 16 18 20 22 24				
Style	A = full perimeter (Fig. 1) B = 3/4 perimeter (Fig. 2)				
Clinch Nut Thread Size	Omit = standard UNC threads M = metric threads				

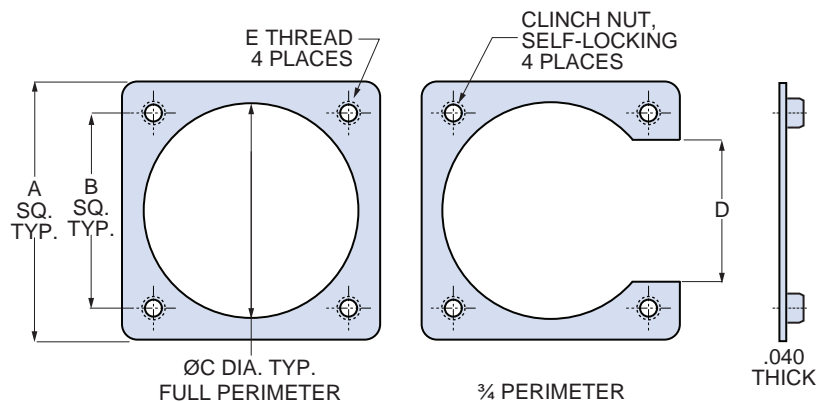

Construction

- Plate: aluminum alloy
- Code E finish: chemical conversion coating per MIL-DTL-5541 Class 1A
- Code EAP finish: epoxy primer per MIL-PRF-23377 Type 1
- Clinch nuts: stainless steel, passivated

Shell Size	A Typ		B		øC		D		E	
	In.	mm.	In.	mm.	In.	mm.	In.	mm.	UNC	Metric
8	.812	20.62	.531	13.49	.494	12.54	.263	6.68	4-40	M3 x 0.5
9	.875	22.23	.594	15.09	.562	14.27	.326	8.28	4-40	M3 x 0.5
10	.903	22.94	.625	15.88	.630	16.00	.357	9.07	4-40	M3 x 0.5
11	.950	24.13	.670	17.02	.697	17.70	.402	10.21	4-40	M3 x 0.5
12	1.028	26.11	.765	19.43	.753	19.13	.497	12.62	4-40	M3 x 0.5
14	1.123	28.52	.859	21.82	.875	22.23	.591	15.01	4-40	M3 x 0.5
16	1.217	30.91	.938	23.83	1.000	25.40	.670	17.02	4-40	M3 x 0.5
18	1.308	33.22	1.016	25.81	1.110	28.19	.748	19.00	4-40	M3 x 0.5
20	1.434	36.42	1.109	28.17	1.260	32.00	.789	20.04	6-32	M4 x 0.7
22	1.560	39.62	1.203	30.56	1.385	35.18	.883	22.43	6-32	M4 x 0.7
24	1.686	42.82	1.312	33.32	1.510	38.35	.992	25.20	6-32	M4 x 0.7

ULTRAMINIATURE CIRCULAR Series 806 Mighty Mouse Mil-Aero Connectors



Hex jam nuts for Mighty Mouse receptacles

Replacement hex jam-nut for series 806 jam-nut mount receptacles. Optional wire holes available where jam-nuts must be safety-wired to prevent loosening.



How To Order					
SAMPLE PART NUMBER		806-035	ME	10	W
Product	806-035 = Hex jam-nut for Series 806 Receptacles				
Finish	See material and finish table				
Shell Size	7 8 9 10 11 12 14 16 18 20 22 24				
Wire Holes	W = Ø .06 wire hole; omit for none				

Dimensions			
Shell Size	'A' Hex	'B' Thread	'C'
7	.76 (19.3)	M8 X 1.06h 0.100 R	.88 (22.4)
8	.82 (20.8)	M15 X 1.06h 0.100 R	.92 (23.4)
9	.86 (21.8)	M16 X 1.06h 0.100 R	.97 (24.6)
10	.94 (23.9)	M18 X 1.06h 0.100 R	1.06 (26.9)
11	.98 (24.9)	M19 X 1.06h 0.100 R	1.10 (27.9)
12	1.06 (26.9)	M21 X 1.06h 0.100 R	1.19 (30.2)
14	1.26 (32.0)	M24 X 1.06h 0.100 R	1.42 (36.1)
16	1.31 (33.3)	M27 X 1.06h 0.100 R	1.48 (37.6)
18	1.41 (35.8)	M30 X 1.06h 0.100 R	1.60 (40.6)
20	1.58 (40.1)	M34 X 1.06h 0.100 R	1.79 (45.5)
22	1.71 (43.4)	M37 X 1.06h 0.100 R	1.394 (35.4)
24	1.86 (47.2)	M41 X 1.06h 0.100 R	2.12 (53.8)

Material/Finish		
Code	Material	Finish
NF	Aluminum Alloy	CAD/O.D. OVER ELECTROLESS NICKEL
MT		NICKEL-PTFE
ME		ELECTROLESS NICKEL (96 HOUR SALT SPRAY)
ZR		ZINC NI, BLACK (TRI-VALENT CR)
Z1	Stainless Steel	PASSIVATE
ZL		ELECTRO-DEPOSITED NICKEL

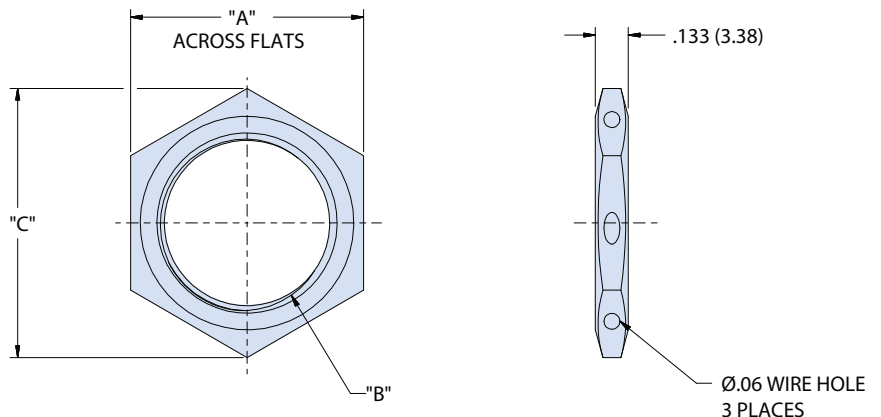

Series 806

Mighty Mouse Mil-Aero Connectors

Protective Covers 667-440, 667-441 and 667-443



Figure 1
667-440 Receptacle Cover

Figure 2
667-441 Plug Cover

Figure 3
667-443 Self-Locking Receptacle Cover

Protect unmated Series 806 connectors with thread-on covers. IP68 ingress protection. Aluminum, stainless steel or composite material. Self-locking receptacle cover features anti-decoupling mechanism for resistance to loosening under vibration.

Construction

- Cover: aluminum alloy, high grade engineering thermoplastic or stainless steel. See ordering info for finish options
- O-ring, gasket: fluorosilicone
- Hardware: stainless steel, passivated
- Lanyard: see Table 1

Table 2 Ring Codes

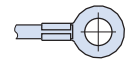
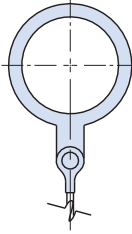
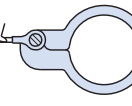
Ring Type	Ring Code	Inside Diameter	
		In.	mm.
No Ring	00	—	—
 Ring Terminal	04	.126	3.20
	06	.145	3.68
	08	.188	4.78
	10	.197	5.00
	12	.423	10.74
	14	.481	12.22
	16	.560	14.22
	18	.600	15.24
	20	.635	16.13
	22	.695	17.65
 Solid Ring	24	.715	18.16
	26	.766	19.46
	28	.845	21.46
	30	.885	22.48
	32	.950	24.13
	34	1.015	25.78
	36	1.070	27.18
	38	1.135	28.83
	40	1.210	30.73
	42	1.275	32.39
 Split Ring	44	1.380	35.05
	46	1.470	37.34
	48	1.625	41.28
	50	.432	10.97
	52	.492	12.50
	54	.648	16.46
	56	.757	19.23
	58	.898	22.81
60	1.023	25.98	
64	1.137	28.88	
68	1.357	34.47	

How To Order

SAMPLE PART NUMBER		667-441	ME	12	U	01	-6
Product	667-440 = Receptacle cover (fig. 1) 667-441 = Plug cover (fig. 2) 667-443 = Receptacle cover, self-locking (fig. 3)						
	Material/ Finish	Material	Finish	Code			
Material/ Finish	Aluminum		Electroless Nickel	ME			
			Nickel-PTFE	MT			
			Olive Drab Cadmium	NF			
			Black Zinc-Nickel	ZR			
	Stainless Steel	Passivate	Z1				
	Composite		Electroless Nickel	XMD			
		Olive Drab Cadmium	XW				
		None	XB				
Shell Size	8 9 10 11 12 14 16 18 20 22 24						
Attachment Lanyard (Table 1)	N = No attachment G = Nylon rope SK = Nylon rope with slip knot U = SST rope with polyurethane coating H = SST rope with high temperature translucent FEP jacket S = Sash chain, #8, SST						
Attachment Ring Code (Table 2)	Omit for attachment types N and SK See Table 2 for ring styles and sizes						
Attachment Length	Omit for attachment type N Lanyard length in inches						

Table 1 Attachment Lanyards

 Nylon Rope (G) -55° to +100°C, black, very flexible, very good abrasion resistance, good resistance to fuels, .120" (3mm) diameter	 Sash Chain (S) Stainless steel, #8 chain, .240" (6mm)
 Polyurethane Coated Wire Rope (U) Black polyurethane over stainless steel rope, -55° to +125°C, very flexible, excellent abrasion resistance, excellent resistance to fuels, .080" (2mm) diameter	 Slip Knot (SK) 55° to +100°C, black, very flexible, very good abrasion resistance, good resistance to fuels, .120" (3mm) diameter. Length includes .5" (13mm) diameter loop.
 Teflon® Jacketed Wire Rope (H) Translucent FEP jacket over stainless steel, -55° to +200°C, fair flexibility, good abrasion resistance, .100" diameter	

667-440 Receptacle Cover

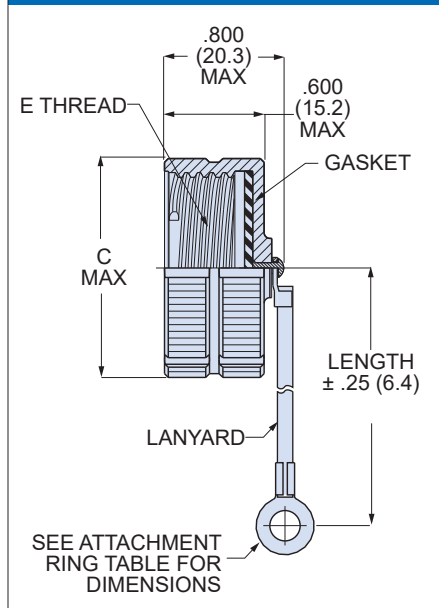

Shell Size	ØC Max		E Thread
	In.	mm.	
8	.640	16.3	.5000-.067P-.2L-TS-2B
9	.703	17.8	.5625-.067P-.2L-TS-2B
10	.765	19.4	.6250-.067P-.2L-TS-2B
11	.828	21.0	.6875-.067P-.2L-TS-2B
12	.890	22.6	.7500-.067P-.2L-TS-2B
14	1.015	25.8	.8750-.067P-.2L-TS-2B
16	1.140	30.0	1.0000-.067P-.2L-TS-2B
18	1.265	32.1	1.1250-.067P-.2L-TS-2B
20	1.390	35.3	1.2500-.067P-.2L-TS-2B
22	1.515	38.5	1.3750-.067P-.2L-TS-2B
24	1.710	43.4	1.5000-.067P-.2L-TS-2B

667-441 Plug Cover

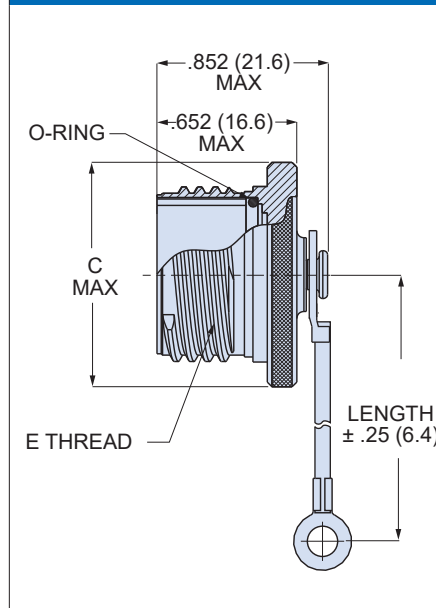

Shell Size	ØC Max		E Thread
	In.	mm.	
8	.676	17.2	.5000-.067P-.2L-TS-2A
9	.771	19.6	.5625-.067P-.2L-TS-2A
10	.832	21.1	.6250-.067P-.2L-TS-2A
11	.890	22.6	.6875-.067P-.2L-TS-2A
12	.950	24.1	.7500-.067P-.2L-TS-2A
14	1.110	28.2	.8750-.067P-.2L-TS-2A
16	1.170	29.7	1.0000-.067P-.2L-TS-2A
18	1.350	34.3	1.1250-.067P-.2L-TS-2A
20	1.470	37.3	1.2500-.067P-.2L-TS-2A
22	1.600	40.6	1.3750-.067P-.2L-TS-2A
24	1.710	43.4	1.5000-.067P-.2L-TS-2A

667-443 Receptacle Cover With Anti-Decoupling Device

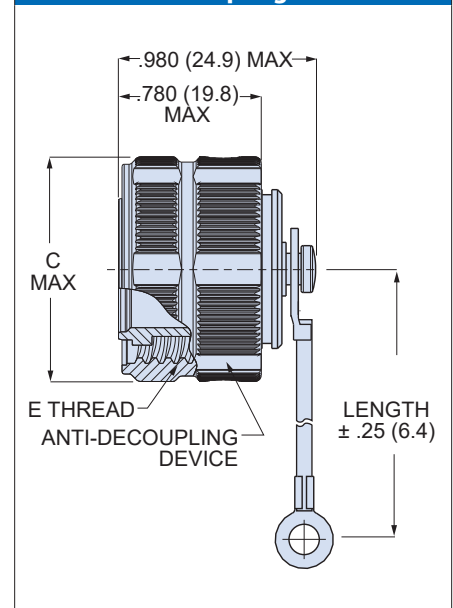

Shell Size	ØC Max		E Thread
	In.	mm.	
8	.676	17.2	.5000-.067P-.2L-TS-2B
9	.771	19.6	.5625-.067P-.2L-TS-2B
10	.832	21.1	.6250-.067P-.2L-TS-2B
11	.890	22.6	.6875-.067P-.2L-TS-2B
12	.950	24.1	.7500-.067P-.2L-TS-2B
14	1.110	28.2	.8750-.067P-.2L-TS-2B
16	1.170	29.7	1.0000-.067P-.2L-TS-2B
18	1.350	34.3	1.1250-.067P-.2L-TS-2B
20	1.470	37.3	1.2500-.067P-.2L-TS-2B
22	1.600	40.6	1.3750-.067P-.2L-TS-2B
24	1.710	43.4	1.5000-.067P-.2L-TS-2B

Attachment Ring Dimensions

Ring Code	Inside Diameter		Max. Outside Diameter	
	In.	mm.	In.	mm.
00	—	—	—	—
04	.126	3.20	.310	7.87
06	.145	3.68	.310	7.87
08	.188	4.78	.310	7.87
10	.197	5.00	.310	7.87
12	.423	10.74	.535	13.59
14	.481	12.22	.593	15.06
16	.560	14.22	.672	17.07
18	.600	15.24	.712	18.08
20	.635	16.13	.770	19.56
22	.695	17.65	.830	21.08

Ring Code	Inside Diameter		Max. Outside Diameter	
	In.	mm.	In.	mm.
24	.715	18.16	.830	21.08
26	.766	19.46	.895	22.73
28	.845	21.46	1.026	26.06
30	.885	22.48	1.026	26.06
32	.950	24.13	1.172	29.77
34	1.015	25.78	1.205	30.61
36	1.070	27.18	1.205	30.61
38	1.135	28.83	1.260	32.00
40	1.210	30.73	1.322	33.58
42	1.275	32.39	1.385	35.18
44	1.380	35.05	1.485	37.72

Ring Code	Inside Diameter		Max. Outside Diameter	
	In.	mm.	In.	mm.
46	1.470	37.34	1.672	42.47
48	1.625	41.28	1.797	45.64
50	.432	10.97	.570	14.48
52	.492	12.50	.630	16.00
54	.648	16.46	.790	20.07
56	.757	19.23	.890	22.61
58	.898	22.81	1.040	26.42
60	1.023	25.98	1.160	29.46
64	1.137	28.88	1.270	32.26
68	1.357	34.47	1.480	37.59



Attachment Ring Application Guide

Attaching a Cover to a Cable-Mounted Connector

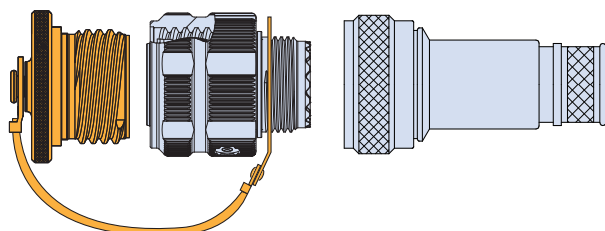

Shell Size	Accessory Thread Size	Max. Thd. Dia.		Recommended Ring Code
		In.	mm.	
8	M10x1.0-6g-0.100R	.393	10	12
9	M12x1.0-6g-0.100R	.471	12	14
10	M14x1.0-6g-0.100R	.550	14	16
11	M15x1.0-6g-0.100R	.589	15	18
12	M17x1.0-6g-0.100R	.668	17	22
14	M19x1.0-6g-0.100R	.747	19	26
16	M22x1.0-6g-0.100R	.865	22	30
18	M25x1.0-6g-0.100R	.983	25	34
20	M28x1.0-6g-0.100R	1.101	28	38
22	M31x1.0-6g-0.100R	1.219	31	42
24	M34x1.0-6g-0.100R	1.338	34	44

Attaching a Receptacle Cover to a Jam Nut Receptacle

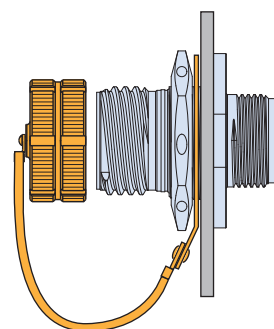

Shell Size	Jam Nut Thread	Max. Thd. Dia.		Recommended Ring Code
		In.	mm.	
8	M15x1.0-6g-0.100R	.589	15	18
9	M16x1.0-6g-0.100R	.629	16	20
10	M18x1.0-6g-0.100R	.707	18	24
11	M19x1.0-6g-0.100R	.747	19	26
12	M21x1.0-6g-0.100R	.827	21	28
14	M24x1.0-6g-0.100R	.944	24	32
16	M27x1.0-6g-0.100R	1.062	27	36
18	M30x1.0-6g-0.100R	1.180	30	40
20	M34x1.0-6g-0.100R	1.338	34	44
22	M37x1.0-6g-0.100R	1.456	37	46
24	M41x1.0-6g-0.100R	1.613	41	48

Attaching a Cover to a Panel

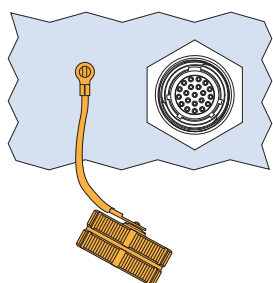

Screw Size	Ring Code	Ring I.D.	
		In. ±.005	mm. ±0.13
#4, M3	04	.126	3.20
#6	06	.145	3.68
#8, M4	08	.188	4.78
#10	10	.197	5.00

Attaching a Cover with Split Ring to a Cordset

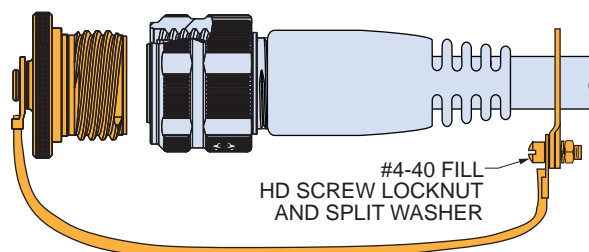

Split Ring Code	Ring I.D.		Split Ring Code	Ring I.D.	
	In.	mm.		In.	mm.
50	.432	10.97	58	.898	22.81
52	.492	12.50	60	1.023	25.98
54	.648	16.46	64	1.137	28.88
56	.757	19.23	68	1.357	34.47

Dummy Stowage Receptacles

Dummy stowage receptacles secure plug ends of cables during maintenance and storage. Mates with Series 806 plug connectors. Universal keying. O-ring provides environmental seal. Aluminum or stainless steel.

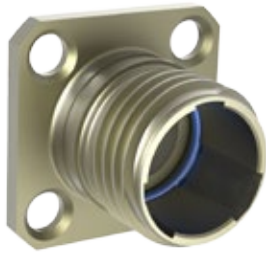

Construction

- Shell: aluminum alloy or stainless steel. See How to Order table for finish options
- O-ring: fluorosilicone

How To Order			
SAMPLE PART NUMBER		650-088	ME
Product		12	
Finish	Material	650-088 = Stowage receptacle for Series 806 plugs	
		Aluminum	Code
		Electroless Nickel	ME
		Nickel-PTFE	MT
		Olive Drab Cadmium	NF
	Black Zinc-Nickel	ZR	
	Stainless Steel	Passivate	Z1
		Nickel	ZL
Shell Size		8 9 10 11 12 14 16 18 20 22 24	

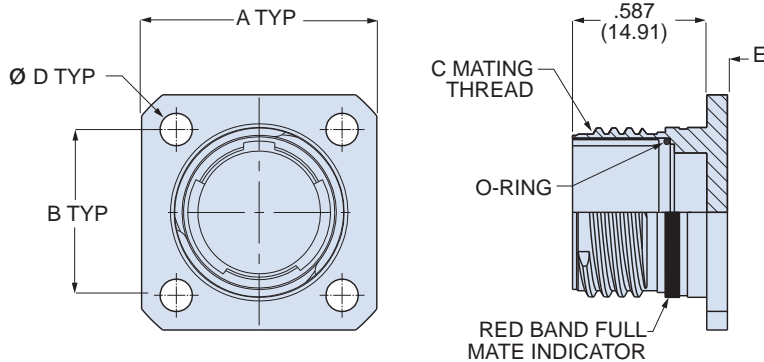

650-088 Dummy Receptacle Dimensions									
Shell Size	A Max		B		C Thread	ØD		E Max	
	In.	mm.	In.	mm.		In.	mm.	In.	mm.
8	.822	20.88	.531	13.49	.5000-.067P-2L-TS-2A	.128	3.25	.100	2.54
9	.885	22.48	.594	15.09	.5625-.067P-2L-TS-2A	.128	3.25	.100	2.54
10	.913	23.19	.625	15.88	.6250-.067P-2L-TS-2A	.128	3.25	.100	2.54
11	.944	23.98	.670	17.02	.6875-.067P-2L-TS-2A	.128	3.25	.100	2.54
12	1.040	26.42	.765	19.43	.7500-.067P-2L-TS-2A	.128	3.25	.100	2.54
14	1.133	28.78	.859	21.82	.8750-.067P-2L-TS-2A	.128	3.25	.100	2.54
16	1.227	31.17	.938	23.83	1.0000-.067P-2L-TS-2A	.128	3.25	.100	2.54
18	1.320	33.53	1.016	25.81	1.1250-.067P-2L-TS-2A	.128	3.25	.100	2.54
20	1.444	36.68	1.109	28.17	1.2500-.067P-2L-TS-2A	.154	3.91	.125	3.18
22	1.570	39.88	1.203	30.56	1.3750-.067P-2L-TS-2A	.154	3.91	.125	3.18
24	1.696	43.08	1.312	33.32	1.5000-.067P-2L-TS-2A	.154	3.91	.125	3.18

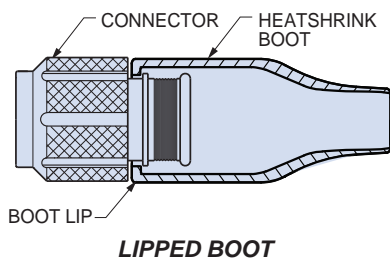

Protect Your Cable Harness with heat-shrinkable boots. These easy-to-use boots provide excellent electrical, mechanical and environmental protection. Heating the boot causes the boot to shrink onto the connector and cable. An adhesive lining bonds the boot to the connector and cable and fills small gaps for a complete seal. These lipped boots attach directly to Series 806 connectors with integral band platform.

Shrink boot installation guide and application instructions are available in the Series 77 Shrink Boot catalog or on the Glenair website.

(www.glenair.com/environmental_shrink_boots/index.htm)

How To Order				
SAMPLE PART NUMBER		809S060	-3	HR
Product	809A060 = 90° boot 809B060 = 45° boot 809S060 = straight boot 809SL060 = straight boot, extended length			
	Boot Size (See Dimension Tables)	1 2 3 4 5 6		
Material and Adhesive Code (material and adhesive information follows dimension tables)	Boot Material	No Adhesive	Pre-coated with Adhesive	
	Standard Type 1 Fluid-Resistant Elastomer	U	Hot Melt Polyamide (W1)	High Performance Epoxy (R)
	Low Smoke/Zero Halogen Type 2 Elastomer	HU	H	HR

809S060 Straight Boots

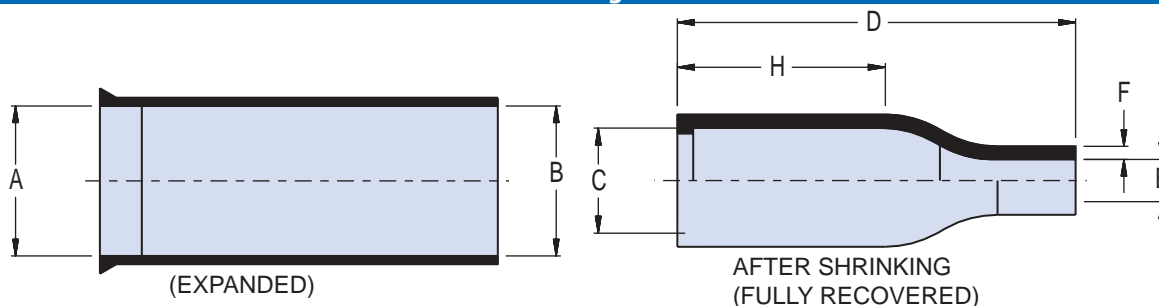

Boot Size	A Min.		B Min.		C Max.		D Ref.		E Max.		F Ref.		H Ref.		Cable Range			
	In.	mm.	In.	mm.	In.	mm.	In.	mm.	In.	mm.	In.	mm.	In.	mm.	Maximum In.	Maximum mm.	Minimum In.	Minimum mm.
1	.390	9.91	.390	9.91	.260	6.60	1.370	34.80	.080	2.03	.030	0.76	.750	19.05	.230	5.84	.100	2.54
2	.669	16.99	.669	16.99	.300	7.62	1.500	38.10	.140	3.56	.032	0.81	.750	19.05	.500	12.70	.170	4.32
3	.945	24.00	.945	24.00	.390	9.91	1.500	38.10	.200	5.08	.035	0.89	.750	19.05	.800	20.32	.240	6.10
4	1.181	30.00	1.181	30.00	.550	13.97	2.170	55.12	.240	6.10	.039	0.99	1.180	29.97	1.020	25.91	.280	7.11
5	1.260	32.00	1.260	32.00	.710	18.03	2.640	67.06	.280	7.11	.039	0.99	1.300	33.02	1.120	28.45	.300	7.62
6	1.417	35.99	1.417	35.99	.900	22.86	3.150	80.01	.330	8.38	.047	1.19	1.570	39.88	1.200	30.48	.350	8.89

809A060 90° Boots

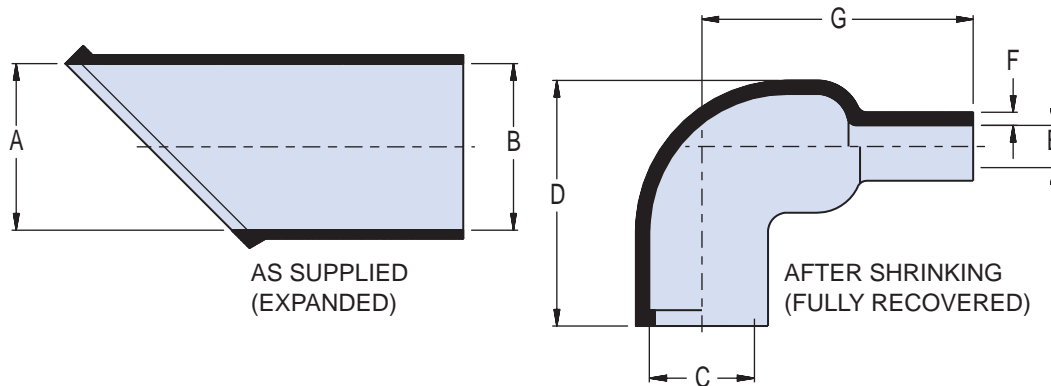

Boot Size	A Min.		B Min.		C Max.		D Ref.		E Max.		F Ref.		G Ref.		Cable Range			
	In.	mm.	In.	mm.	In.	mm.	In.	mm.	In.	mm.	In.	mm.	In.	mm.	Maximum In.	Maximum mm.	Minimum In.	Minimum mm.
1	.390	9.91	.390	9.91	.260	6.60	.790	20.07	.095	2.41	.032	0.81	.750	19.05	.230	5.84	.100	2.54
2	.669	16.99	.669	16.99	.310	7.87	.790	20.07	.140	3.56	.032	0.81	.790	20.07	.500	12.70	.170	4.32
3	.945	24.00	.945	24.00	.390	9.91	.980	24.89	.200	5.08	.040	1.02	.980	24.89	.800	20.32	.240	6.10
4	1.181	30.00	1.181	30.00	.530	13.46	1.060	26.92	.220	5.59	.046	1.17	1.260	32.00	1.020	25.91	.270	6.86
5	1.260	32.00	1.260	32.00	.710	18.03	1.260	32.00	.280	7.11	.052	1.32	1.540	39.12	1.120	28.45	.300	7.62
6	1.417	35.99	1.417	35.99	.900	22.86	1.500	38.10	.330	8.38	.052	1.32	1.930	49.02	1.200	30.48	.350	8.89

809B060 45° Boots

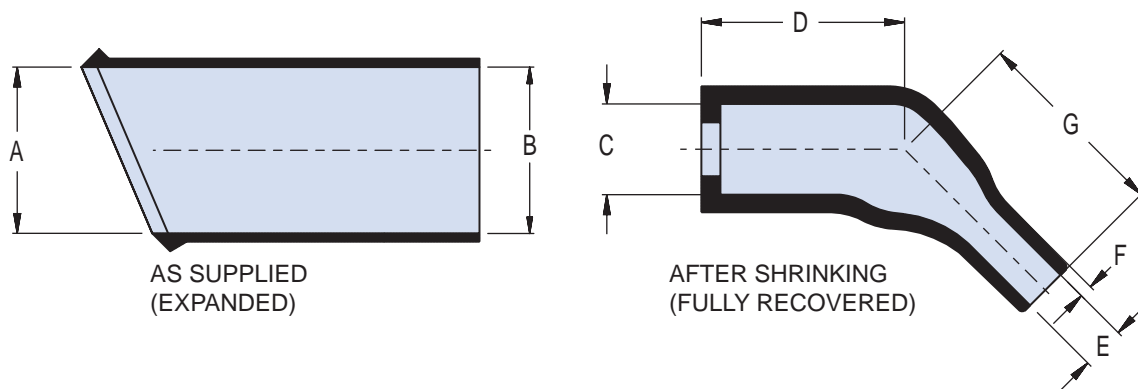

Boot Size	A Min.		B Min.		C Max.		D Ref.		E Max.		F Ref.		G Ref.		Cable Range			
	In.	mm.	In.	mm.	In.	mm.	In.	mm.	In.	mm.	In.	mm.	In.	mm.	Maximum In.	Maximum mm.	Minimum In.	Minimum mm.
1	.390	9.9	.390	9.9	.260	6.60	.600	15.24	.080	2.03	.030	0.76	.560	14.22	.230	5.84	.100	2.54
2	.669	17.0	.669	17.0	.300	7.62	.640	16.26	.140	3.56	.035	0.89	.620	15.75	.500	12.70	.170	4.32
3	.945	24.0	.945	24.0	.390	9.91	.500	12.7	.160	4.06	.040	1.02	.750	19.05	.800	20.32	.240	6.10
4	1.181	30.0	1.181	30.0	.550	13.97	.748	19.00	.230	5.84	.043	1.09	1.180	29.97	1.020	25.91	.280	7.11
5	1.260	32.0	1.260	32.0	.710	18.03	.984	24.99	.280	7.11	.065	1.65	1.380	35.05	1.120	28.45	.300	7.62
6	1.417	35.99	1.417	35.99	.900	22.86	1.260	32.00	.330	8.38	.065	1.65	1.570	39.88	1.200	30.48	.350	8.89



809SL060 Straight Long Tail Boots

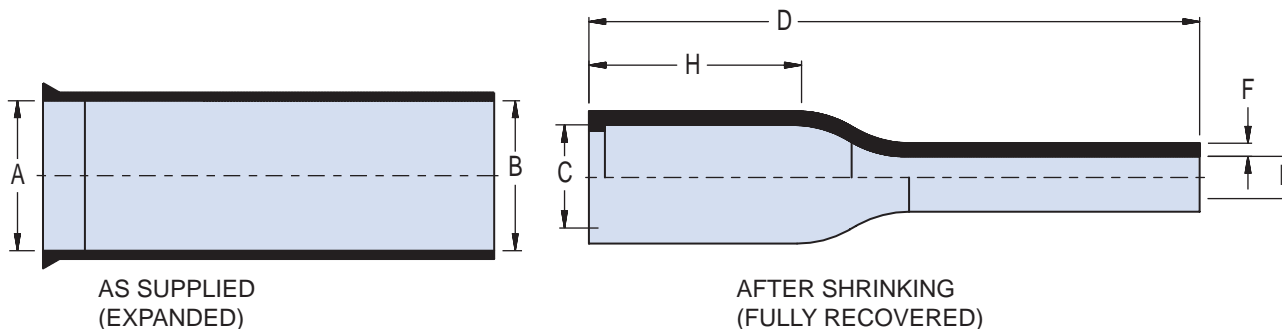

Boot Size	A Min.		B Min.		C Max.		D Ref		E Max.		F Ref.		H Ref.		Cable Range			
	In.	mm.	In.	mm.	In.	mm.	In.	mm.	In.	mm.	In.	mm.	In.	mm.	Maximum In.	Maximum mm.	Minimum In.	Minimum mm.
1	.390	9.9	.390	9.9	.280	7.11	2.500	63.50	.080	2.03	.045	1.14	.750	19.05	.230	5.84	.100	2.54
2	.669	17.0	.669	17.0	.310	7.87	2.500	63.50	.140	3.56	.045	1.14	.750	19.05	.500	12.70	.170	4.32
3	.945	24.0	.945	24.0	.390	9.91	2.500	63.50	.200	5.08	.045	1.14	.750	19.05	.800	20.32	.240	6.10
4	1.181	30.0	1.181	30.0	.550	13.97	3.000	76.20	.240	6.10	.045	1.14	1.180	29.97	1.020	25.91	.280	7.11

Boot Material Information

Type 1 High Performance Elastomer

Semi-rigid high performance boots combine excellent resistance to fuels, oils and solvents with superior performance at extreme temperatures. Material meets the requirements of VG95343 Type 6, BSG 198-5-DE, EN62329-102 and SAE AS5258 Type H. These boots are ideal for demanding applications such as military vehicles and petrochemical exploration.

Type 2 Zero halogen

Halogen-free polyolefin boots meet low smoke and toxicity requirements of shipboard, transit and aircraft systems. These Low Smoke/Zero Halogen (LSZH) boots meet the requirements of NAVSEA 5617649, VG95343 Part 29, BSG 198-5-DF, EN62329-101 and SAE AS5258 Type G. Resistance to oils, fuels and solvents.

Shrink Boot Typical Material Properties

Property	Type 1 High Performance Elastomer	Type 2 Zero Halogen Polyolefin
Flexibility	Semi-rigid	Semi-flexible
Operating Temperature Range	-75°C to +165°C	-40°C to +130°C
Shrink Temperature (min.)	135°C	135°C
Tensile Strength (psi)	1700	1100
Elongation (% min.)	400	250
Long Term Heat Aging	3000 hrs, 150°C	3000 hrs, 135°C
Heat Shock	4 hrs, 215°C	4 hrs, 215°C
Heat Aging	168 hrs, 160°C	168 hrs, 160°C
Dielectric Strength (V/mil)	300	380
Volume Resistivity (ohms-cm)	10 ¹³	10 ¹²
Water Absorption (%)	0.5	0.5
Flammability	Burn Time <15 sec	Burn Length <25mm
RoHS Compliant	Yes	Yes
Oxygen Index (% min.)	N/A	30
Temperature Index (OC)	N/A	250
Smoke Index (max.)	N/A	20
Toxicity Index (max.)	N/A	3
Lubricating Oil Resistance	Very Good	Good
Hydraulic Fluid Resistance	Very Good	Good
Aviation Fuel Resistance	Very Good	Good
Gasoline Resistance	Very Good	Fair
De-icing Fluid Resistance	Excellent	Very Good
Automotive Diesel Resistance	Good	Fair

Pre-Coat Adhesive Properties

Attribute	W1 Standard Polyamide Hot Melt Adhesive	R High Performance Epoxy Pre-coat
Continuous Operating Temp.	-55° to +125°C	-75° to +150°C
Resistance to Fuels, Oils & Fluids	Good	
Low Toxicity, Zero Halogen	Yes	
IEC 62329-2 Dynamic Shear, 23°C	300N	300N
IEC 62329-2 Dynamic Shear, 100°C	30N	110N
IEC 62329-2 Dynamic Shear, 150°C	(not rated)	30N
IEC 62329-2 Heat Shock, 4 hrs., 215°C	Peel adhesion > 60N/25mm Dynamic shear > 300N	
IEC 62329-2 Heat Aging, 168 hrs., 160°C	Peel adhesion > 60N/25mm Dynamic shear > 300N	
IEC 62329-2 Peel Adhesion	>60N/25mm	
IEC 62329-2 Fluid Resistance Lubricating Oil 0-156 Aircraft Grease G-354 Hydraulic Fluid H-520 Water Turbine Fuel F-34	24 hrs. immersion @ 70°C Dynamic shear > 150N	



About Series 806 Backshells

Series 806 connectors are available with a rear thread for attaching cable clamps and backshells. The connector-to-backshell interface is based on the metric threads found on MIL-DTL-38999 Series III and Series IV connectors. The Series 806 has 11 accessory thread sizes. Four thread sizes are unique to the Series 806, and the remaining seven thread sizes are also found on the MIL-DTL-38999 connectors. Series 806 accessories are designated with a unique interface code "V". However, for the seven Series 806 connector sizes that have the

same accessory thread size as a MIL-DTL-38999, Glenair "H" code accessories can be used. The table at right shows the equivalent MIL-DTL-38999 shell sizes.

Series 806 Backshell Compatibility

- Shell sizes 8, 10, 12 and 14 require V code accessories.
- Other sizes are compatible with H code accessories.

Series 806 Accessory Threads		
Shell Size	Thread Size	MIL-DTL-38999 Series III/IV Shell Size
8	M10	No equivalent
9	M12	(A) 9
10	M14	No equivalent
11	M15	(B) 11
12	M17	No equivalent
14	M19	No equivalent
16	M22	(D) 15
18	M25	(E) 17
20	M28	(F) 19
22	M31	(G) 21
24	M34	(H) 23

STRAIN RELIEF CLAMPS



620-081
Composite Strain Relief Clamp
Straight, 45° and 90°
Page 51



620-080
Strain Relief Clamp
Aluminum or SST, self-locking
Page 68



627-234
Low-Profile Swing-Arm® Flex with Drop-in EMI Adapter
Page 50

EMI RFI BANDING ADAPTERS



440-191
Band/Boot Adapters
Aluminum or stainless steel.
Page 57



440-202
Composite Band/Boot Adapters
These composite self-locking adapters are lightweight and corrosion resistant.
Page 59



317-111
Piggyback Boot Adapter
These composite, self-locking backshells have a drop-in banding adapter and are supplied with pre-attached shrink boot.
Page 62



EMI BACKSHELLS



380-143
EMI Backshell

These self-locking backshells are available in aluminum or stainless steel.
Page 53



387-243
Composite EMI

Ground rings for shield termination.
Page 52



390-091
EMI Environmental

Aluminum or SST. Submersible.
Page 55

"BAND-IN-A-CAN" BANDING ADAPTERS



4470-1061
Composite Band-in-a-Can

Use with Band-Master ATS® shield termination bands. Saddle clamps provide cable strain relief. Non-environmental.
Page 64



443-039
Aluminum or SST Band-in-a-Can

Use with Band-Master ATS® shield termination bands. Environmentally protected with O-rings.
Page 66

COMPOSITE QWIK-TY



457-048
Composite Qwik-Ty with Drop-In EMI Adapter

Drop-in adapter terminates to cable braid shield.
Page 63

SHORTING CAP



340VS035
Shorting Backshell

Page 69



Drop-In EMI Adapter

Terminate cable braid shield to adapter with Band-Master ATS® strap. Slots in adapter are used for individual shield pigtails.



Straight, 45° or 90°

Loosen screws and re-position flex arms for optimum wire routing.

Construction

- Body, Coupling Nut, Flex Arms: high grade engineering thermoplastic, black
- Hardware: stainless steel, passivated
- Anti-Rotation Device: high grade engineering thermoplastic

Lightweight. Low Profile. Composite. Self-Locking. EMI. Flexible strain relief adjusts to various wire bundle sizes. Attach cable ties or band to flex arms for strain relief. Terminate cable shields to plated brass EMI adapter with Band-Master ATS® banding strap. Straight, 45° or 90° cable exit. Composite thermoplastic body, coupling nut and flex arms. Compatible with Glenair Series 806 ultraminiature circular connectors.

How To Order			
Shell Size	Shield Termination Adapter Finish		
	Electroless Nickel Code BM	Nickel-PTFE Code BMT	Olive Drab Cadmium Code BN
8		Not Available	
9	627V234BM09	627V234BMT09	627V234BN09
10	627V234BM10	627V234BMT10	627V234BN10
11	627V234BM11	627V234BMT11	627V234BN11
12	627V234BM12	627V234BMT12	627V234BN12
14	627V234BM14	627V234BMT14	627V234BN14
16	627V234BM16	627V234BMT16	627V234BN16
18	627V234BM18	627V234BMT18	627V234BN18
20	627V234BM20	627V234BMT20	627V234BN20
22	627V234BM22	627V234BMT22	627V234BN22
24	627V234BM24	627V234BMT24	627V234BN24

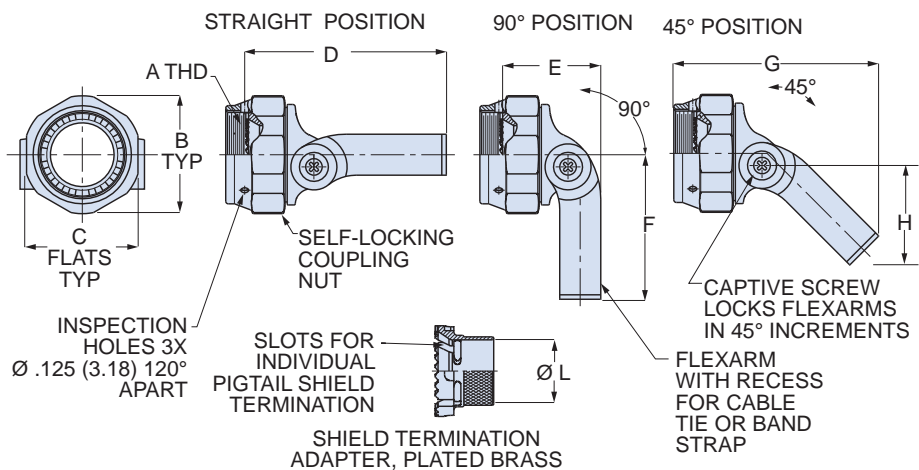

Shell Size	A ISO Metric Thread	øB Max.		C Max.		D Max.		E Max.		F Max.		G Max.		H Max.		ø L	
		In.	mm.	In.	mm.	In.	mm.	In.	mm.	In.	mm.	In.	mm.	In.	mm.		
9	M12 x 1.0-6H	.812	20.62	.750	19.05	1.77	44.96	.73	18.54	1.09	27.69	.73	18.54	1.08	27.43	.178	4.5
10	M14 x 1.0-6H	.938	23.83	.875	22.23	1.77	44.96	.73	18.54	1.12	28.45	.70	17.78	1.11	28.19	.295	7.5
11	M15 x 1.0-6H	.938	23.83	.875	22.23	1.77	44.96	.73	18.54	1.12	28.45	.70	17.78	1.11	28.19	.305	7.7
12	M17 x 1.0-6H	1.125	26.58	1.000	25.40	2.05	52.07	.84	21.34	1.41	35.81	.81	20.57	1.34	28.23	.394	10.0
14	M19 x 1.0-6H	1.125	26.58	1.000	25.40	2.05	52.07	.84	21.34	1.41	35.81	.81	20.57	1.34	28.23	.472	12.0
16	M22 x 1.0-6H	1.250	31.75	1.125	28.58	2.05	52.07	.84	21.34	1.47	37.34	.75	19.05	1.42	36.07	.565	14.4
18	M25 x 1.0-6H	1.375	34.93	1.250	31.75	2.26	57.40	.94	23.88	1.65	41.91	.88	22.35	1.54	39.12	.658	16.7
20	M28 x 1.0-6H	1.500	38.10	1.375	34.93	2.26	57.40	.94	23.88	1.71	43.43	.81	20.57	1.63	41.40	.777	19.7
22	M31 x 1.0-6H	1.625	41.28	1.500	38.10	2.72	69.09	1.04	26.42	2.09	53.09	.94	23.88	1.97	50.04	.873	22.2
24	M34x 1.0-6H	1.750	44.45	1.625	41.28	2.72	69.09	1.04	26.42	2.13	54.10	.90	22.86	2.02	51.31	.997	25.3



Lightweight. Straight, 45° or 90°. Composite. Self-Locking. Spin coupling backshell with full radius cable clamp provides protection for open wire bundles or jacketed cable. Compatible with Glenair Series 806 ultraminiature circular connectors.

How To Order			
SAMPLE PART NUMBER	620VS081		
		XM	12
Product	620VS081 = Cable Clamp, Straight 620VB081 = Cable Clamp, 45° 620VA081 = Cable Clamp, 90°		
Adapter Finish	XB = Unplated (black) XM = Electroless nickel XMT = Nickel/PTFE XW = Olive Drab Cadmium XZN = Zinc nickel (black) Coupling nut and saddle clamps are unplated black thermoplastic		
Shell Size	08 09 10 11 12 14 16 18 20 22 24		

Features

- Corrosion resistant high strength engineering thermoplastic
- Self-locking spin coupling
- Non-environmental

Specifications

- Operating temperature: codes XB, XM, XMT: -65°C to +200°C
codes XZN, XW: -65°C to +175°C
- Salt spray (corrosion): 2000 hours
- Vibration: SAE AS85049 Category 4C
- Shock: SAE AS85049 Category 4C

Construction

- Adapter: high grade engineering thermoplastic. See How to Order for finish options
- Coupling nut, saddle clamps: high grade engineering thermoplastic, no plating, black
- Hardware: stainless steel, passivated
- Anti-Rotation Device: high grade engineering thermoplastic

Notes

1. Cable entry is measured with the saddle clamps closed and bottomed on clamp ears.

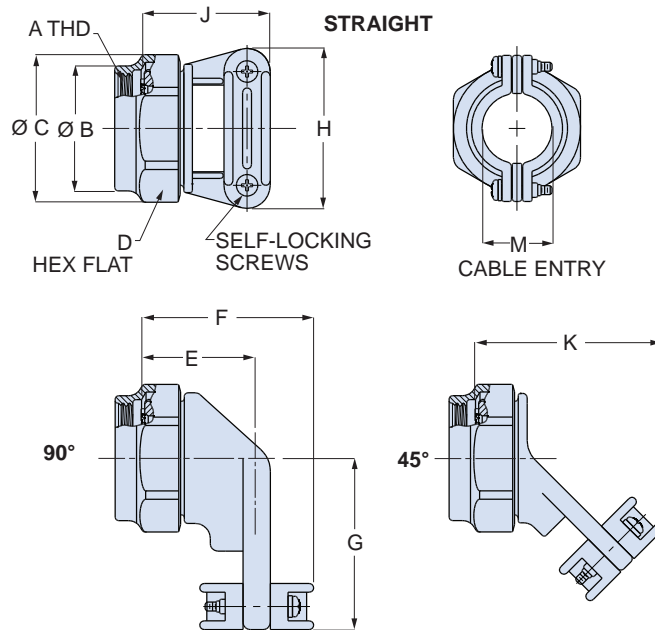

Shell Size	A ISO Metric Thread	øB Max.		øC Max.		D Hex		E Ref.		F		G		H		J		K Max.		M	
		In.	mm.	In.	mm.	In.	mm.	In.	mm.	In.	mm.	In.	mm.	In.	mm.	In.	mm.	In.	mm.	In.	mm.
08	M10 x 1.0-6H	.65	16.5	.86	21.8	.75	19.1	.63	16.0	.86	21.8	.88	22.4	.88	22.4	.80	20.3	1.32	33.5	.218	5.5
09	M12 x 1.0-6H	.65	16.5	.86	21.8	.75	19.1	.63	16.0	.86	21.8	.88	22.4	.88	22.4	.80	20.3	1.32	33.5	.218	5.5
10	M14 x 1.0-6H	.77	19.5	.98	24.9	.88	22.2	.65	16.5	.91	23.1	.94	23.9	.94	23.9	.88	22.4	1.35	34.3	.264	6.7
11	M15 x 1.0-6H	.77	19.5	.98	24.9	.88	22.2	.65	16.5	.91	23.1	.94	23.9	.94	23.9	.88	22.4	1.35	34.3	.264	6.7
12	M17 x 1.0-6H	.89	22.6	1.16	29.5	1.00	25.4	.71	18.0	1.02	25.9	1.03	26.2	1.17	29.7	1.00	25.4	1.43	36.3	.345	8.8
14	M19 x 1.0-6H	1.03	26.2	1.28	32.5	1.13	28.6	.76	19.3	1.13	28.7	1.13	28.7	1.28	32.5	1.00	25.4	1.48	37.6	.461	11.7
16	M22 x 1.0-6H	1.03	26.2	1.28	32.5	1.13	28.6	.76	19.3	1.13	28.7	1.13	28.7	1.28	32.5	1.00	25.4	1.48	37.6	.461	11.7
18	M25 x 1.0-6H	1.15	29.2	1.41	35.8	1.25	31.8	.80	20.3	1.26	32.0	1.31	33.3	1.41	35.8	1.13	28.7	1.58	40.1	.544	13.8
20	M28 x 1.0-6H	1.28	32.5	1.52	38.6	1.38	34.9	.83	21.1	1.31	33.3	1.38	35.1	1.50	38.1	1.19	30.2	1.70	43.2	.614	15.6
22	M31 x 1.0-6H	1.41	35.8	1.64	41.7	1.50	38.1	.90	22.9	1.37	34.8	1.50	38.1	1.56	39.6	1.25	31.8	1.74	44.2	.697	17.7
24	M34 x 1.0-6H	1.53	38.9	1.77	45.0	1.63	41.3	.94	23.9	1.45	36.8	1.63	41.4	1.69	42.9	1.38	35.1	1.79	45.5	.780	19.8



Features

- Corrosion resistant high strength engineering thermoplastic
- Self-locking spin coupling
- Non-environmental
- Three shield ferrules

Specifications

- Operating temperature: codes XM, XMT: -65°C to +200°C codes XW: -65°C to +175°C
- Salt spray (corrosion): 2000 hours
- Vibration: SAE AS85049 Category 4C
- Shock: SAE AS85049 Category 4C

Construction

- Adapter: high grade engineering thermoplastic. See How to Order for finish options
- Coupling nut, saddle clamps, clamp body: high grade engineering thermoplastic, no plating, black
- Ferrules: aluminum alloy. See How to Order for finish options.
- Hardware: stainless steel, passivated
- Anti-decoupling device: high grade engineering thermoplastic

Notes

1. Cable entry is measured with the saddle clamps closed and bottomed on clamp ears.

Composite. Straight or 90°. Shielded. Self-Locking. Corrosion-resistant EMI backshell features high strength thermoplastic construction. Aluminum alloy shield termination rings. Self-locking coupling ring and cable clamp screws. Nickel, cadmium, or nickel-PTFE finish.

How To Order					
SAMPLE PART NUMBER	387VS243	XM	12	06	-4
Product	387VS243 = Straight Adapter 387VW243 = 90° Adapter				
Material/ Finish	XM = Electroless nickel XMT = Nickel/PTFE XW = Olive Drab Cadmium				
Shell Size	08 09 10 11 12 14 16 18 20 22 24				
Cable Entry Code	See Table 1 for cable entry sizes				
Adapter Length	<i>Omit for 90° version. Applicable to 387VS243 only.</i> Length in ¼ inch increments: 4 = 1 inch (min.) 5 = 1.25 inches 6 = 1.5 inches 8 = 2 inches				

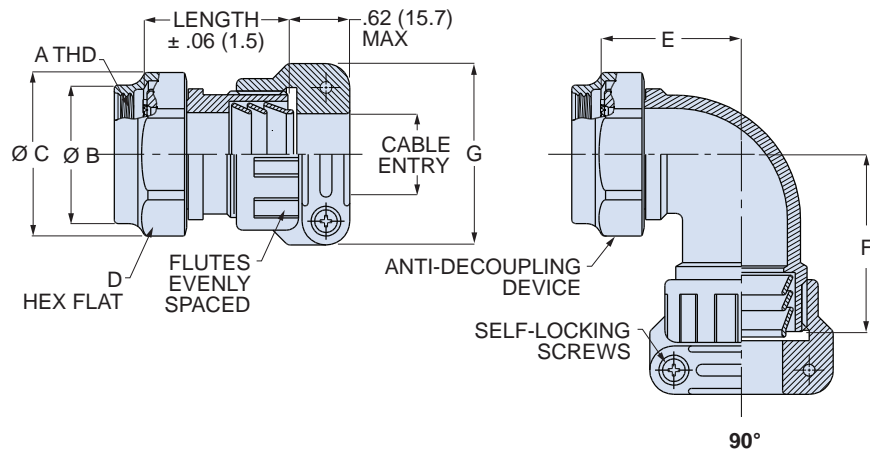

Table 1 Cable Entry Code

Cable Entry Code	Cable Entry ±.039 (1.0)		G Max.	
	In.	mm.	In.	mm.
04	.312	7.9	1.125	28.6
06	.437	11.1	1.250	31.8
08	.500	12.7	1.312	33.3
10	.625	15.9	1.438	36.5
12	.750	19.1	1.625	41.3
14	.874	22.2	1.688	42.9
16	.937	23.8	1.750	44.5
17	1.094	27.8	1.906	48.5

Table 2 Dimensions

Shell Size	A ISO Metric Thread	ØB Max.		ØC Max.		D Hex		E ±.078 (2.0)		F ±.078 (2.0)		Max. Cable Entry
		In.	mm.	In.	mm.	In.	mm.	In.	mm.	In.	mm.	
08	M10 x 1.0-6H	.65	16.5	.86	21.8	.75	19.1	.722	18.3	1.750	44.4	04
09	M12 x 1.0-6H	.65	16.5	.86	21.8	.75	19.1	.722	18.3	1.750	44.4	04
10	M14 x 1.0-6H	.77	19.5	.98	24.9	.88	22.2	.784	19.9	1.820	46.2	06
11	M15 x 1.0-6H	.77	19.5	.98	24.9	.88	22.2	.784	19.9	1.820	46.2	06
12	M17 x 1.0-6H	.89	22.6	1.16	29.5	1.00	25.4	.816	20.7	1.860	47.2	08
14	M19 x 1.0-6H	1.03	26.2	1.28	32.5	1.13	28.6	.878	22.3	1.880	47.8	10
16	M22 x 1.0-6H	1.03	26.2	1.28	32.5	1.13	28.6	.878	22.3	1.880	47.8	10
18	M25 x 1.0-6H	1.15	29.2	1.41	35.8	1.25	31.8	.942	23.9	1.942	49.3	12
20	M28 x 1.0-6H	1.28	32.5	1.52	38.6	1.38	34.9	1.003	25.5	2.000	5.8	14
22	M31 x 1.0-6H	1.41	35.8	1.64	41.7	1.50	38.1	1.037	26.3	2.062	52.4	16
24	M34 x 1.0-6H	1.53	38.9	1.77	45.0	1.63	41.3	1.116	28.3	2.194	55.7	17

ULTRAMINIATURE CIRCULAR

Series 806

Mighty Mouse Mil-Aero Connectors

380-143 Metal EMI/RFI Backshell



EMI shielding. Self-locking. Straight, 45° or 90°. Non-environmental. 380-143 backshells fit Glenair Series 806 connectors. These spin coupling backshells have ground rings for cable braid shield termination. Heavy duty saddle clamp with stainless steel telescoping screws. Meets requirements of AS85049 Category 3C medium duty. Aluminum or stainless steel.

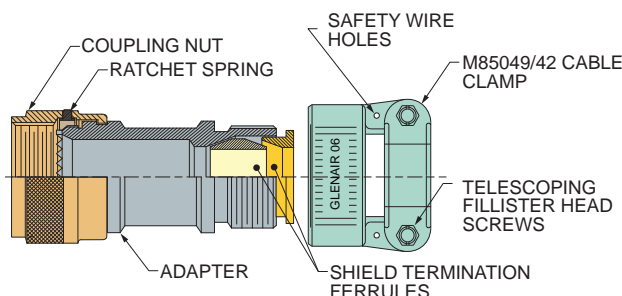

Features

- EMI/RFI protected
- Self-locking spin coupling
- Telescoping clamp screws
- Non-environmental

Specifications

- Operating temperature: codes ME, MT and Z1: -65°C to +200°C codes ZR, NF: -65°C to +175°C
- Shell conductivity: aluminum versions: 2.5 milliohms max. Stainless steel: 5 milliohms max.
- Salt spray (corrosion) Code ME: 96 hours Code NF, ZR, MT, Z1: 1000 hours
- Vibration: SAE AS85049 Category 3C
- Shock: SAE AS85049 Category 3C

Construction

- Coupling nut, adapter, ferrules, clamps: see material/finish codes
- Anti-decoupling device: corrosion-resistant material
- Hardware: stainless steel, passivated

How To Order						
SAMPLE PART NUMBER	380VS143	ME	12	06	H	4
Product	380VS143 = EMI Backshell, Straight 380VM143 = EMI Backshell, 45° 380VN143 = EMI Backshell, 90°					
Material/ Finish	ME = Aluminum, Electroless Nickel MT = Aluminum, Ni/PTFE ZR = Aluminum, Black Zinc-Nickel NF = Aluminum, Olive Drab Cadmium Z1 = Stainless Steel, Passivated					
Shell Size	09 10 11 12 14 16 18 20 22 24					
Cable Clamp Size	See Table 1 for cable clamp sizes					
Strain Relief Clamp	H = Saddle bar clamp, heavy duty, with telescoping screws					
Backshell Length	Omit for 45° and 90° versions. Applicable to 380VS143 only. Length in 1/2 inch increments: 3 = 1 1/2 inches (min. for Style 1 shown at right) 4 = 2 inches (min. for Style 2 shown on following page) 5 = 2 1/2 inches 6 = 3 inches					

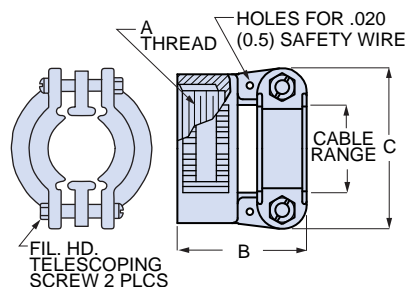
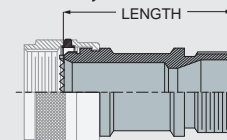
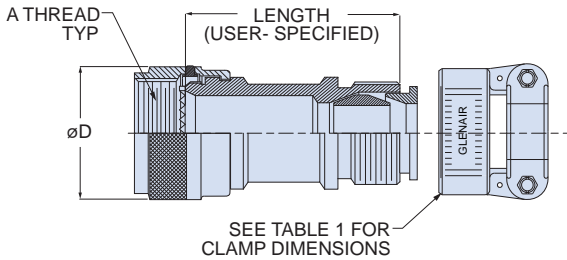

Table 1 Cable Clamp Size									
Clamp Size	Cable Range				A Thread Class 2B	B Max.		C Max.	
	Min. In.	Min. mm.	Max. In.	Max. mm.		In.	mm.	In.	mm.
04	.125	3.2	.312	7.9	.625-24UNEF	1.301	33.04	.957	24.3
06	.250	6.4	.437	11.1	.750-20UNEF	1.301	33.04	1.145	29.1
08	.312	7.9	.562	14.3	.875-20UNEF	1.301	33.04	1.332	33.8
10	.350	8.9	.625	15.9	1.000-20UNEF	1.301	33.04	1.332	33.8
12	.500	12.7	.750	19.1	1.1875-18UNEF	1.332	33.83	1.551	39.4
16	.625	15.9	.937	23.8	1.4375-18UNEF	1.426	36.22	1.770	45.0
20	.875	22.2	1.250	31.8	1.750-18UNS	1.613	40.97	2.113	53.7
24	1.000	25.4	1.375	34.9	2.000-18UNS	1.645	41.78	2.363	60.0

380VS143

Straight Exit



380VM143

45° Exit

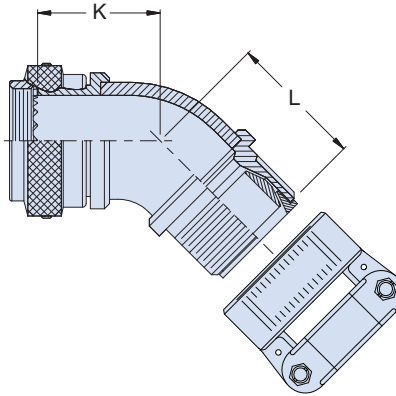

380VN143

90° Exit

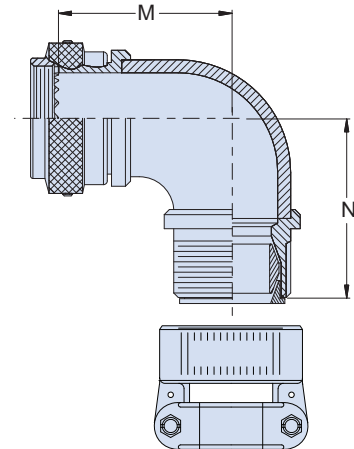

Shell Size	A ISO Metric Thread	øD Max.		K Max. ⁽¹⁾		L Max.		M Max. ⁽¹⁾		N Max.		Max. Clamp Size ⁽¹⁾	Max. Cable Dia. ⁽¹⁾	
		In.	mm.	In.	mm.	In.	mm.	In.	mm.	In.	mm.		In.	mm.
09	M12 x 1.0-6H	.735	18.67	.790	20.07	1.070	27.18	.940	23.88	1.230	31.24	04	.312	7.9
10	M14 x 1.0-6H	.786	19.96	.790	20.07	1.130	28.70	.970	24.64	1.320	33.53	04	.312	7.9
11	M15 x 1.0-6H	.830	21.08	.790	20.07	1.130	28.70	.970	24.64	1.320	33.53	06	.437	11.1
12	M17 x 1.0-6H	.911	23.14	.830	21.08	1.210	30.73	1.040	26.42	1.420	36.07	06	.437	11.1
14	M19 x 1.0-6H	1.002	25.45	.830	21.08	1.210	30.73	1.040	26.42	1.420	36.07	08	.562	14.3
16	M22 x 1.0-6H	1.149	29.18	.840	21.34	1.280	32.51	1.080	27.43	1.520	38.61	10	.625	14.3
18	M25 x 1.0-6H	1.264	32.11	.890	22.61	1.360	34.54	1.140	28.96	1.620	41.15	12	.750	19.1
20	M28 x 1.0-6H	1.394	35.41	.920	23.37	1.430	36.32	1.210	30.73	1.710	43.43	16	.937	23.8
22	M31 x 1.0-6H	1.513	38.43	.950	24.13	1.490	37.85	1.280	32.51	1.810	45.97	16	.937	23.8
24	M34 x 1.0-6H	1.631	41.43	.980	24.89	1.550	39.37	1.330	33.78	1.910	48.51	16	.937	23.8

(1) If the maximum clamp size is exceeded, the backshell will be a "Style 2" with a transition adapter as shown below. The K and M dimensions will be increased by 1.00 inch (25.4 mm.) maximum.

Style 2 Backshells for Large Diameter Cables

If the cable clamp is larger than the maximum clamp size shown in the table above, the backshell will be supplied with a **transition adapter** and a second coupling nut. This type of backshell is called a **Style 2**. The large diameter of the Style 2 backshell allows it to slide over the cable until the connector is wired and ready for backshell installation. On straight exit backshells, the transition adapter does not affect the length. On 45° and 90° versions the transition adapter adds 1.00 inch (25.4mm) maximum to the backshell length.

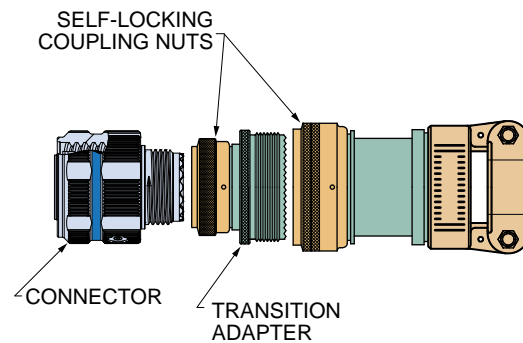

Style 2 Backshell

ULTRAMINIATURE CIRCULAR

Series 806

Mighty Mouse Mil-Aero Connectors

390-091 Metal EMI/RFI Submersible Backshell



EMI shielding. Submersible. Self-locking. Straight, 45° or 90°. For use with shielded, jacketed cable. Compatible with Series 806 ultraminiature connectors. Terminate cable shield to inner and outer ground rings. Heavy duty cable clamps. Aluminum or stainless steel with silicone O-rings and gland. Stainless steel telescoping clamp screws. Meets environmental, electrical and mechanical requirements of AS85049 Category 1A Heavy Duty.

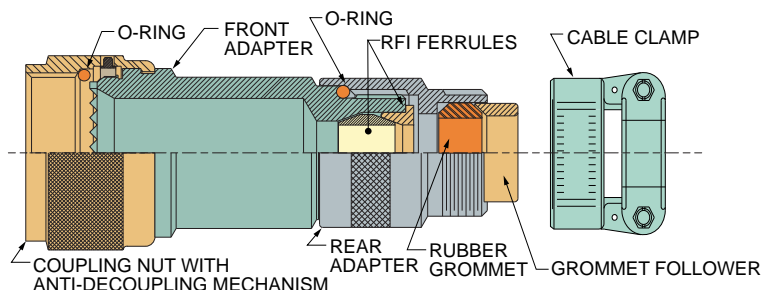

Features

- EMI/RFI protected
- Self-locking spin coupling
- Telescoping clamp screws
- Submersible, environmental

Specifications

- Operating temperature: codes ME, MT and Z1: -65°C to +200°C codes ZR, NF: -65°C to +175°C
- Shell conductivity: aluminum versions: 2.5 milliohms max. Stainless steel: 5 milliohms max.
- Salt spray (corrosion) Code ME: 96 hours Code NF, ZR, MT, Z1: 1000 hours
- Vibration: SAE AS85049 Category 1A
- Shock: SAE AS85049 Category 1A
- Water pressure: SAE AS85049 Cat. 1A

Construction

- Coupling nut, adapters, ferrules, clamps, follower: see material/finish codes
- O-rings, grommet: silicone
- Anti-decoupling device: corrosion-resistant material
- Hardware: stainless steel, passivated

How To Order						
SAMPLE PART NUMBER	390VS091	ME	12	06	H	4
Product	390VS091 = Straight Backshell 390VM091 = 45° Backshell 390VN091 = 90° EMI Backshell					
Material/ Finish	ME = Aluminum, Electroless Nickel MT = Aluminum, Ni/PTFE ZR = Aluminum, Black Zinc-Nickel NF = Aluminum, Olive Drab Cadmium Z1 = Stainless Steel, Passivated					
Shell Size	09 10 11 12 14 16 18 20 22 24					
Cable Clamp Size	See Table 1 for cable clamp sizes					
Strain Relief Clamp	H = Saddle bar clamp, heavy duty, with telescoping screws					
Backshell Length	Omit for 45° and 90° versions. Applicable to 390VS091 only. Length in 1/2 inch increments: 3 = 1 1/2 inches (min. for Style 1) 4 = 2 inches (min. for Style 2) 5 = 2 1/2 inches 6 = 3 inches					

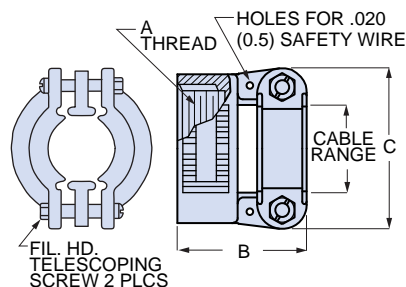
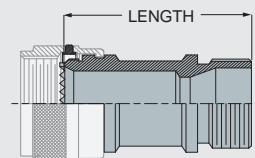
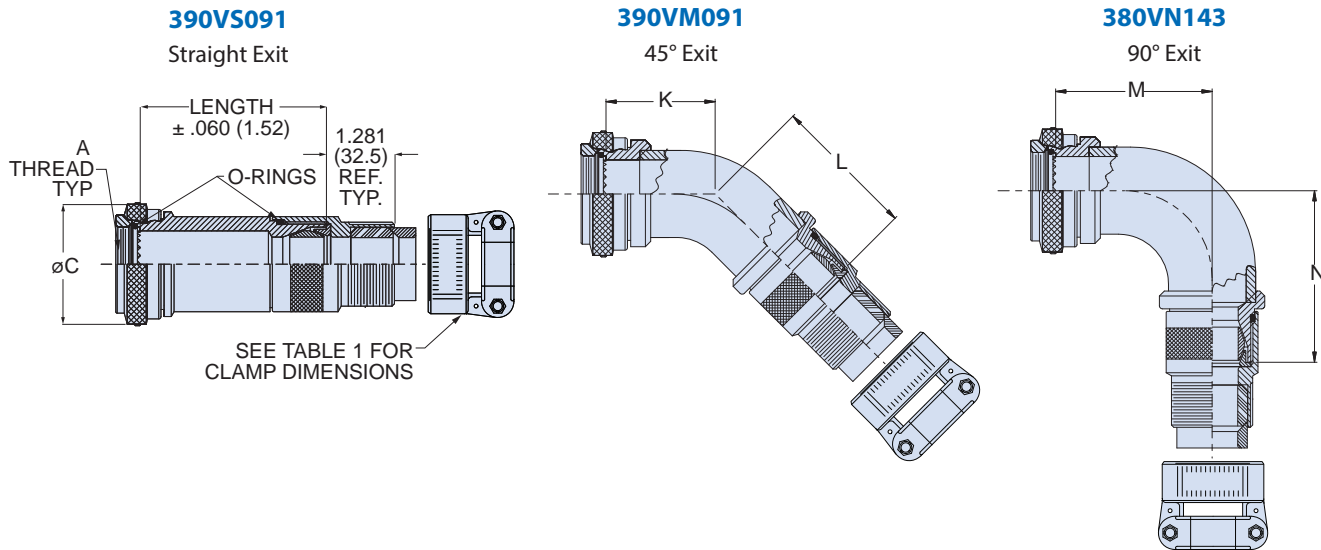

Table 1 Cable Clamp Size									
Clamp Size	Cable Range				A Thread Class 2B	B Max.		C Max.	
	Min. In.	Min. mm.	Max. In.	Max. mm.		In.	mm.	In.	mm.
04	.125	3.2	.312	7.9	.625-24UNEF	1.301	33.04	.957	24.3
06	.250	6.4	.437	11.1	.750-20UNEF	1.301	33.04	1.145	29.1
08	.312	7.9	.562	14.3	.875-20UNEF	1.301	33.04	1.332	33.8
10	.350	8.9	.625	15.9	1.000-20UNEF	1.301	33.04	1.332	33.8
12	.500	12.7	.750	19.1	1.1875-18UNEF	1.332	33.83	1.551	39.4
16	.625	15.9	.937	23.8	1.4375-18UNEF	1.426	36.22	1.770	45.0
20	.875	22.2	1.250	31.8	1.750-18UNS	1.613	40.97	2.113	53.7
24	1.000	25.4	1.375	34.9	2.000-18UNS	1.645	41.78	2.363	60.0



SEE TABLE 1 FOR CLAMP DIMENSIONS

Shell Size	A ISO Metric Thread	øC Max.		K Max. ⁽¹⁾		L Max.		M Max. ⁽¹⁾		N Max.		Max. Clamp Size ⁽¹⁾	Max. Cable Dia. ⁽¹⁾	
		In.	mm.	In.	mm.	In.	mm.	In.	mm.	In.	mm.		In.	mm.
09	M12 x 1.0-6H	.786	19.96	.790	20.07	1.070	27.18	.940	23.88	1.230	31.24	04	.312	7.9
10	M14 x 1.0-6H	.883	22.43	.790	20.07	1.130	28.70	.970	24.64	1.320	33.53	04	.312	7.9
11	M15 x 1.0-6H	.911	23.14	.790	20.07	1.130	28.70	.970	24.64	1.320	33.53	06	.437	11.1
12	M17 x 1.0-6H	1.002	25.45	.830	21.08	1.210	30.73	1.040	26.42	1.420	36.07	06	.437	11.1
14	M19 x 1.0-6H	1.066	27.08	.830	21.08	1.210	30.73	1.040	26.42	1.420	36.07	08	.562	14.3
16	M22 x 1.0-6H	1.196	30.38	.840	21.34	1.280	32.51	1.080	27.43	1.520	38.61	10	.625	14.3
18	M25 x 1.0-6H	1.311	33.30	.890	22.61	1.360	34.54	1.140	28.96	1.620	41.15	12	.750	19.1
20	M28 x 1.0-6H	1.430	36.32	.920	23.37	1.430	36.32	1.210	30.73	1.710	43.43	16	.937	23.8
22	M31 x 1.0-6H	1.548	39.32	.950	24.13	1.490	37.85	1.280	32.51	1.810	45.97	16	.937	23.8
24	M34 x 1.0-6H	1.696	43.08	.980	24.89	1.550	39.37	1.330	33.78	1.910	48.51	16	.937	23.8

(1) If the maximum clamp size is exceeded, the backshell will be a "Style 2" with a transition adapter as shown below. The K and M dimensions will be increased by 1.00 inch (25.4 mm.) maximum.

Style 2 Backshells for Large Diameter Cables

If the cable clamp is larger than the maximum clamp size shown in the table above, the backshell will be supplied with a **transition adapter** and a second coupling nut. This type of backshell is called a **Style 2**. The large diameter of the Style 2 backshell allows it to slide over the cable until the connector is wired and ready for backshell installation. On straight exit backshells, the transition adapter does not affect the length. On 45° and 90° versions the transition adapter adds 1.00 inch (25.4mm) maximum to the backshell length.

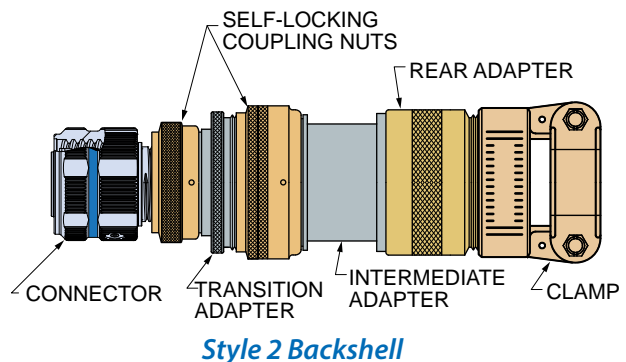



Features

- EMI/RFI
- Self-locking spin coupling
- Band-Master shield termination

Specifications

- Operating temperature: codes ME, MT and Z1: -65°C to +200°C codes ZR, NF, NFP: -65°C to +175°C
- Shell conductivity: aluminum versions: 2.5 milliohms max. Stainless steel: 5 milliohms max.
- Salt spray (corrosion) Code ME, NFP: 96 hours Code NF, ZR, MT, Z1: 1000 hours
- Vibration: SAE AS85049 Category 3B
- Shock: SAE AS85049 Category 3B

Construction

- Coupling nut, adapter: aluminum alloy or 300 series stainless steel. See material/finish options in How to Order table.
- O-ring: silicone
- Anti-decoupling device: corrosion-resistant material

EMI shielding. Band-Master ATS® shield termination. Self-locking. Environmental. Spin coupling EMI/RFI adapter with anti-decoupling ratchet prevents loosening under vibration. Fits Series 806 connectors. Terminate cable shield to backshell with **Band-Master ATS®** stainless steel band. Compatible with Glenair Series 77 lipped heatshrink boots. Straight, 45° or 90° cable exit. Aluminum or stainless steel.

How To Order						
SAMPLE PART NUMBER	440VS191	ME	12	06	-4	K
Product	440VS191 = Straight Adapter 440VH191 = 45° Adapter 440VJ191 = 90° Adapter					
Material/ Finish	ME = Aluminum, Electroless Nickel MT = Aluminum, Ni/PTFE ZR = Aluminum, Black Zinc-Nickel NF = Aluminum, Olive Drab Cadmium NFP = Aluminum, Olive Drab Cadmium, nickel-plated shield termination area, polysulfide barrier Z1 = Stainless Steel, Passivated					
Shell Size	08 09 10 11 12 14 16 18 20 22 24					
Cable Entry Code	See Table 1 for cable entry sizes					
Adapter Length	Omit for 45° and 90° versions. Applicable to 440VS191 only. Length in 1/2 inch increments: 3 = 1 1/2 inches (min. for Style 1 shown at right) 4 = 2 inches (min. for Style 2 shown on following page) 5 = 2 1/2 inches 6 = 3 inches					
Optional Band Strap	Omit if bands will be purchased separately. K = Adapter supplied with pre-coiled band strap 601-041					

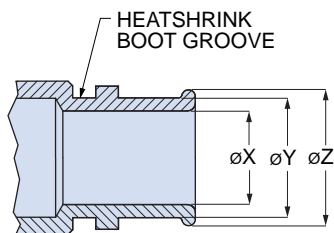
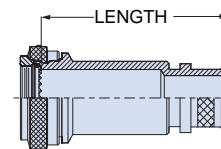
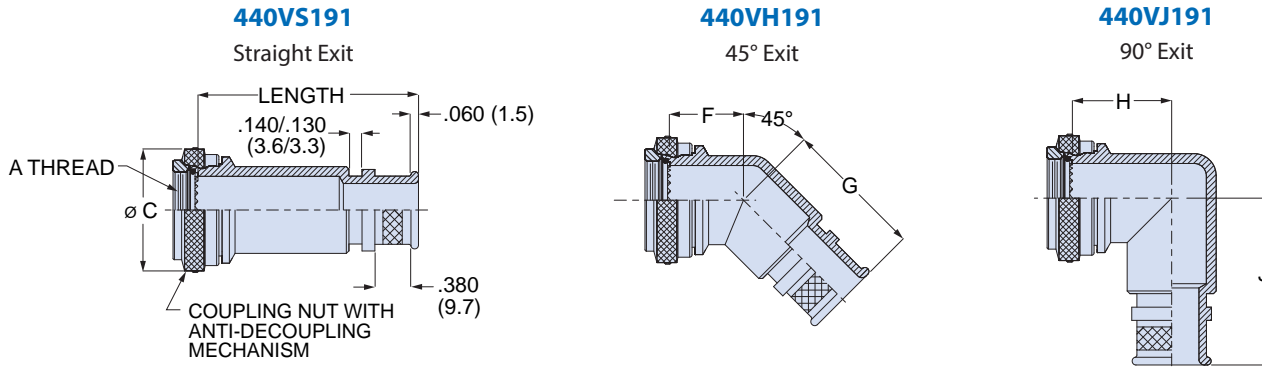

Table 1 Cable Entry

Cable Entry Code	ø X Typ.		ø Y Typ.		ø Z Typ.		Cable Entry Code	ø X Typ.		ø Y Typ.		ø Z Typ.	
	In.	mm.	In.	mm.	In.	mm.		In.	mm.	In.	mm.	In.	mm.
02	.125	3.2	.250	6.4	.312	7.9	13	.812	20.6	.938	23.8	1.000	25.4
03	.188	4.8	.312	7.9	.374	9.5	14	.875	22.2	1.000	25.4	1.062	27.0
04	.250	6.4	.375	9.5	.437	11.1	15	.938	23.8	1.062	27.0	1.124	28.5
05	.312	7.9	.438	11.1	.500	12.7	16	1.000	25.4	1.125	28.6	1.187	30.1
06	.375	9.5	.500	12.7	.562	14.3	17	1.062	27.0	1.188	30.2	1.250	31.8
07	.438	11.1	.562	14.3	.624	15.8	18	1.125	28.6	1.250	31.8	1.312	33.3
08	.500	12.7	.625	15.9	.687	17.4	20	1.250	31.8	1.375	34.9	1.437	36.5
09	.562	14.3	.688	17.5	.750	19.1	22	1.375	34.9	1.500	38.1	1.562	39.7
10	.625	15.9	.750	19.1	.812	20.6	24	1.500	38.1	1.625	41.3	1.687	42.8
11	.688	17.5	.812	20.6	.874	22.2	26	1.625	41.3	1.750	44.5	1.812	46.0
12	.750	19.1	.875	22.2	.937	23.8	28	1.750	44.5	1.875	47.6	1.937	49.2



Shell Size	A ISO Metric Thread	øC Max.		F Max. ⁽¹⁾		G Max.		H Max. ⁽¹⁾		J Max.		Max. Cable Entry Code ⁽¹⁾	Max. Cable Entry Dia. ⁽¹⁾	
		In.	mm.	In.	mm.	In.	mm.	In.	mm.	In.	mm.		In.	mm.
08	M10 x 1.0-6H	.692	17.58	.640	16.26	.920	23.37	.760	19.30	1.130	28.70	04	.250	6.4
09	M12 x 1.0-6H	.786	19.96	.650	16.51	.960	24.38	.790	20.07	1.180	29.97	05	.312	7.9
10	M14 x 1.0-6H	.883	22.43	.680	17.27	.990	25.15	.840	21.34	1.230	31.24	06	.375	9.5
11	M15 x 1.0-6H	.911	23.14	.690	17.53	1.020	25.91	.850	21.59	1.240	31.50	07	.438	11.1
12	M17 x 1.0-6H	1.002	25.45	.720	18.29	1.050	26.67	.900	22.86	1.290	32.77	08	.500	12.7
14	M19 x 1.0-6H	1.066	27.08	.730	18.54	1.080	27.43	.930	23.62	1.320	33.53	09	.562	14.3
16	M22 x 1.0-6H	1.196	30.38	.770	19.56	1.150	29.21	1.000	25.40	1.400	35.56	11	.688	17.5
18	M25 x 1.0-6H	1.311	33.30	.800	20.32	1.210	30.73	1.050	26.67	1.490	37.85	13	.812	20.6
20	M28 x 1.0-6H	1.430	36.32	.840	21.34	1.270	32.26	1.110	28.19	1.580	40.13	15	.938	23.8
22	M31 x 1.0-6H	1.548	39.32	.870	22.10	1.320	33.53	1.170	29.72	1.660	42.16	17	1.062	27.0
24	M34 x 1.0-6H	1.696	43.08	.920	23.37	1.390	35.31	1.250	31.75	1.770	44.96	18	1.125	28.6

(1) If the maximum cable entry code is exceeded, the backshell will be a "Style 2" with a transition adapter as shown below. The F and H dimensions will be increased by 1.00 inch (25.4 mm.) maximum.

Style 2 Adapters for Large Diameter Cables

If the cable entry diameter exceeds the maximum cable entry code shown in the above table, the adapter will be supplied with a **transition adapter**. On straight exit backshells, the transition adapter does not affect the length. On 45° and 90° versions the transition adapter adds 1.00 inch (25.4mm) maximum to the backshell length.

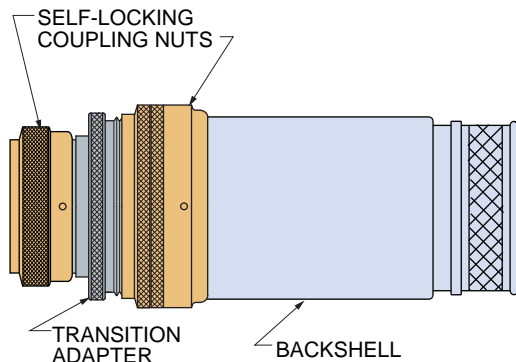

Application Note: Selective Plated Cadmium with Polysulfide Barrier

Olive drab (OD) cadmium (Cd) over electroless nickel (EN) is available in two versions. The standard version, designated as Glenair code **NF**, is a uniform Cd/EN finish over the entire part. A second version, designated as Glenair code **NFP**, is selectively plated with electroless nickel in the knurled shield attachment area. A polysulfide barrier separates the electroless nickel area from the cadmium plated area. This selectively plated version prevents galvanic corrosion that could potentially occur if nickel-coated shield braid is attached to a cadmium plated surface.

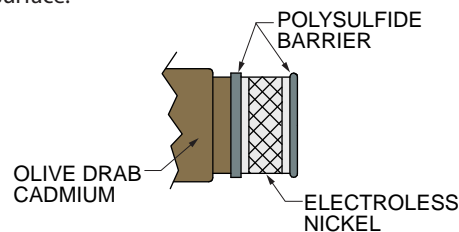

ULTRAMINIATURE CIRCULAR

Series 806

Mighty Mouse Mil-Aero Connectors

440-202 Composite EMI/RFI Banding Adapter



Lightweight. Corrosion-resistant composite. Band-Master ATS® shield termination. Self-locking. Integral Qwik-Ty. Spin coupling EMI/RFI adapter with anti-decoupling ratchet prevents loosening under vibration. Fits Series 806 connectors. Terminate cable shield to backshell with **Band-Master ATS®** stainless steel band. Compatible with Glenair Series 77 lipped heatshrink boots. Straight, 45° or 90° cable exit.

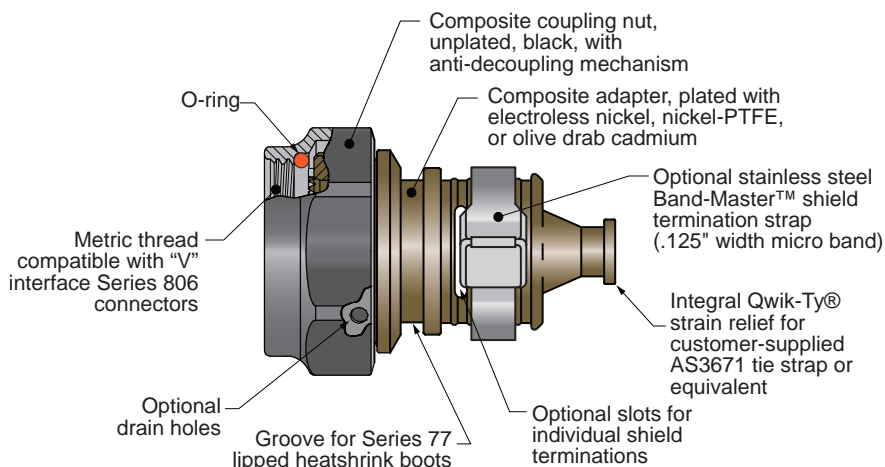

Features

- EMI/RFI
- Self-locking spin coupling
- Integral Qwik-Ty® strain relief

Specifications

- Operating temperature: codes XM, XMT: -65°C to +200°C; codes XW: -65°C to +175°C
- Salt spray (corrosion): 2000 hours
- Vibration: SAE AS85049 Category 3B
- Shock: SAE AS85049 Category 3B

Construction

- Adapter: high grade engineering thermoplastic with electroless nickel (code XM), nickel-PTFE (XMT) or olive drab cadmium (XW)
- Coupling nut: high grade engineering thermoplastic, no plating, black
- Anti-decoupling device: high grade engineering thermoplastic
- Shield termination strap: 300 series stainless steel, passivated

Notes

- If drain holes are supplied, the O-ring is deleted.

How To Order																																							
SAMPLE PART NUMBER	440VS202 XM 14 09																																						
Product	440VS202 = Straight Adapter 440VT202 = 45° Adapter 440VA202 = 90° Adapter																																						
Finish	XM = Electroless nickel XMT = Nickel/PTFE XW = Olive Drab Cadmium																																						
Shell Size	08 09 10 11 12 14 16 18 20 22 24																																						
Entry Code	<table border="1"> <thead> <tr> <th rowspan="2">Shell Size</th> <th rowspan="2">Entry Code</th> <th colspan="2">Diameter</th> </tr> <tr> <th>In.</th> <th>mm.</th> </tr> </thead> <tbody> <tr> <td>08, 09, 10, 11</td> <td>04</td> <td>.25</td> <td>6.4</td> </tr> <tr> <td>10, 11, 18</td> <td>05</td> <td>.31</td> <td>7.9</td> </tr> <tr> <td>12, 20</td> <td>07</td> <td>.44</td> <td>11.2</td> </tr> <tr> <td>14, 16, 22</td> <td>09</td> <td>.56</td> <td>14.2</td> </tr> <tr> <td>18, 24</td> <td>11</td> <td>.68</td> <td>17.3</td> </tr> <tr> <td>20</td> <td>13</td> <td>.81</td> <td>20.6</td> </tr> <tr> <td>22</td> <td>15</td> <td>.94</td> <td>23.9</td> </tr> <tr> <td>24</td> <td>16</td> <td>1.00</td> <td>25.4</td> </tr> </tbody> </table>	Shell Size	Entry Code	Diameter		In.	mm.	08, 09, 10, 11	04	.25	6.4	10, 11, 18	05	.31	7.9	12, 20	07	.44	11.2	14, 16, 22	09	.56	14.2	18, 24	11	.68	17.3	20	13	.81	20.6	22	15	.94	23.9	24	16	1.00	25.4
Shell Size	Entry Code			Diameter																																			
		In.	mm.																																				
08, 09, 10, 11	04	.25	6.4																																				
10, 11, 18	05	.31	7.9																																				
12, 20	07	.44	11.2																																				
14, 16, 22	09	.56	14.2																																				
18, 24	11	.68	17.3																																				
20	13	.81	20.6																																				
22	15	.94	23.9																																				
24	16	1.00	25.4																																				
Optional Drain Holes	Omit for no drain holes. D = Adapter supplied with coupling nut drain holes																																						
Optional Band Strap	Omit for no band strap. B = Adapter supplied with shield termination band																																						
Optional Shield Termination Slots	Omit for unslotted version. S = Adapter supplied with shield termination slots																																						

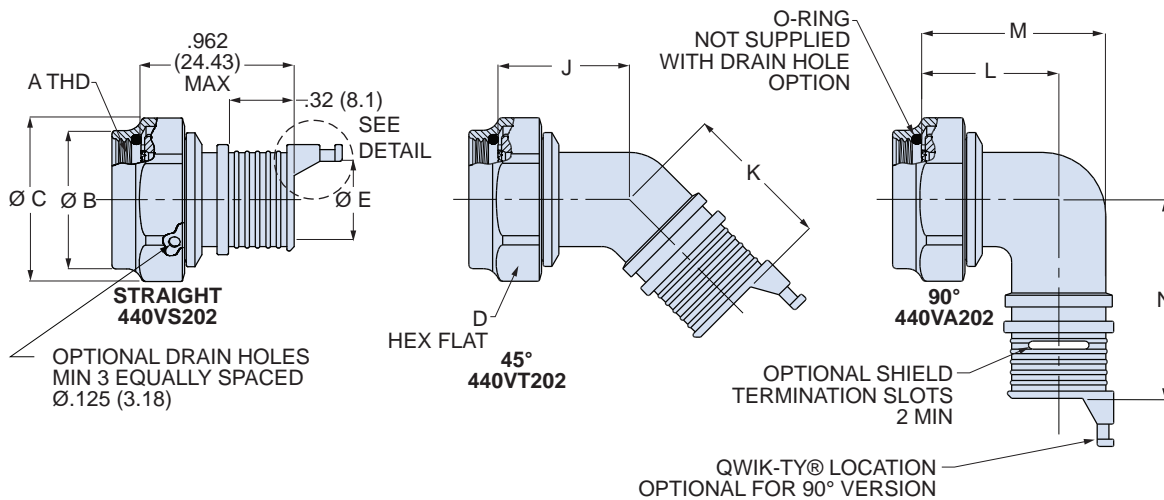
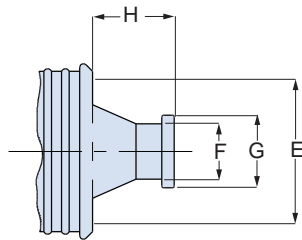

Table 1 Dimensions

Shell Size	Available Entry Codes	A ISO Metric Thread	ØB Max.		ØC Max.		D Hex		L ± .09 (2.3)		M ± .09 (2.3)		N Max.	
			In.	mm.	In.	mm.	In.	mm.	In.	mm.	In.	mm.	In.	mm.
08	04	M10 x 1.0-6H	.65	16.5	.86	21.8	.75	19.1	.69	17.5	.88	22.4	1.36	34.5
09	04	M12 x 1.0-6H	.65	16.5	.86	21.8	.75	19.1	.69	17.5	.88	22.4	1.36	34.5
10	04, 05	M14 x 1.0-6H	.77	19.5	.98	24.9	.88	22.2	.75	19.1	1.00	25.4	1.42	36.1
11	04, 05	M15 x 1.0-6H	.77	19.5	.98	24.9	.88	22.2	.75	19.1	1.00	25.4	1.42	36.1
12	07	M17 x 1.0-6H	.89	22.6	1.16	29.5	1.00	25.4	.81	20.6	1.13	28.7	1.48	37.6
14	09	M19 x 1.0-6H	1.03	26.2	1.28	32.5	1.13	28.6	.88	22.4	1.13	28.7	1.48	37.6
16	09	M22 x 1.0-6H	1.03	26.2	1.28	32.5	1.13	28.6	.88	22.4	1.31	33.3	1.55	39.4
18	05, 11	M25 x 1.0-6H	1.15	29.2	1.41	35.8	1.25	31.8	.94	23.9	1.38	35.1	1.61	40.9
20	07, 13	M28 x 1.0-6H	1.28	32.5	1.52	38.6	1.38	34.9	.97	24.6	1.44	36.6	1.64	41.7
22	09, 15	M31 x 1.0-6H	1.41	35.8	1.64	41.7	1.50	38.1	1.06	26.9	1.63	41.4	1.73	43.9
24	11, 15	M34 x 1.0-6H	1.53	38.9	1.77	45.0	1.63	41.3	1.13	28.7	1.75	44.5	1.80	45.7

Table 2 Entry Codes and Qwik-Ty Dimensions

Entry Code	ØE ± .03 (0.8)		F		G		H		J ± .06 (1.5)		K ± .09 (2.3)	
	In.	mm.	In.	mm.	In.	mm.	In.	mm.	In.	mm.	In.	mm.
04	.25	6.4	.187	4.74	.312	7.92	.512	13.0	.72	18.3	.87	22.1
05	.31	7.9	.187	4.74	.312	7.92	.512	13.0	.75	19.1	.93	23.6
07	.44	11.2	.187	4.74	.312	7.92	.512	13.0	.75	19.1	1.00	25.4
09	.56	14.2	.219	5.56	.375	9.53	.630	16.0	.76	19.3	1.03	26.2
11	.68	17.3	.219	5.56	.375	9.53	.630	16.0	.78	19.8	1.05	26.7
13	.81	20.6	.219	5.56	.375	9.53	.630	16.0	.79	20.1	1.06	26.9
15	.94	23.9	.219	5.56	.375	9.53	.630	16.0	.82	20.8	1.09	27.7
16	1.00	25.4	.219	5.56	.375	9.53	.630	16.0	.86	21.8	1.13	28.7



QWIK-TY® DETAIL AND ENTRY DIAMETER

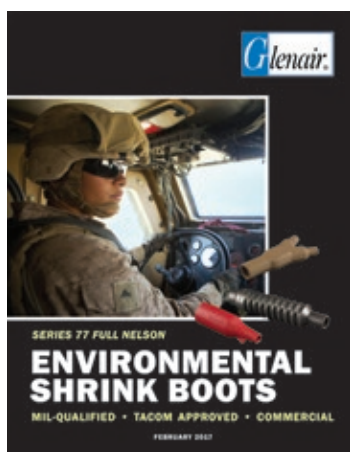

770-003 heatshrink boots fit 440-191 and 440-202 banding adapters. These lipped boots provide electrical, mechanical and environmental protection. Type 1 high performance elastomer or Type 2 Low Smoke/ Zero Halogen material. Optional adhesive lining bonds the boot to the connector and cable and fills small gaps for a complete seal.

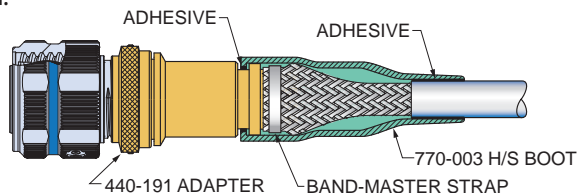

How To Order				
SAMPLE PART NUMBER	770-003S	1	03	W1
Product	770-003S = Straight boot			
Material	1 = High performance elastomer 2 = Zero Halogen polyolefin			
Boot Size	See Table 1 for boot size			
Adhesive Lining	Omit for no adhesive W1 = Hot melt polyamide pre-coat (+125° C) R = One part epoxy pre-coat (+150° C)			

Heatshrink boots are available in many styles, materials and configurations to fit any requirement. Refer to the **Series 77 "Full Nelson" Environmental Shrink Boots** catalog for a complete listing of heatshrink products, technical information and installation guides

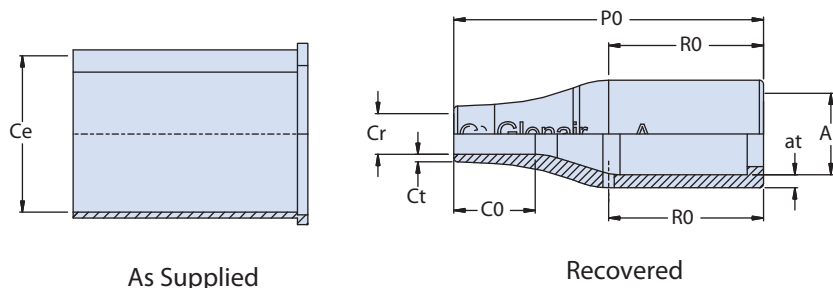

MATERIAL SELECTION GUIDE

High Performance Elastomer

-75°C to +150°C semi-rigid elastomer combines excellent resistance to fuels, oils and solvents with superior performance at extreme temperatures. Recommended for demanding applications such as military vehicles and petrochemical exploration.

Zero Halogen Polyolefin

-30°C to +135°C Low Smoke Zero Halogen (LSZH) polyolefin boots meet toxicity requirements of shipboard, transit and aircraft systems. Semi-flexible, good resistance to oils, fuels and solvents.

Table 1 Boot Size and Dimensions									
Boot Size	Adapter Size	Ce	Ar	at	Cr	ct	CO	PO	RO
		Dia. Min.	Dia. Max.	±30%	Dia. Max.	±20%	Ref.	±10%	Ref.
11	02, 03	.472 (12.0)	.276 (7.0)	.043 (1.1)	.093 (2.4)	.028 (0.7)	.354 (9.0)	1.417 (36.0)	.750 (19.1)
12	04, 05	.669 (17.0)	.375 (9.5)	.051 (1.3)	.187 (4.7)	.028 (0.7)	.394 (10.0)	1.496 (38.0)	.750 (19.1)
03	06	.945 (24.0)	.413 (10.5)	.063 (1.6)	.197 (5.0)	.035 (0.9)	.394 (10.0)	1.496 (38.0)	.748 (19.0)
04	07, 08, 09, 10, 11	1.181 (30.0)	.551 (14.0)	.071 (1.8)	.236 (6.0)	.039 (1.0)	.630 (16.0)	2.165 (55.0)	1.181 (30.0)
05	12, 13, 14, 15	1.260 (32.0)	.709 (18.0)	.071 (1.8)	.276 (7.0)	.047 (1.2)	.748 (19.0)	2.638 (67.0)	1.299 (33.0)
06	16, 17	1.417 (36.0)	.866 (22.0)	.079 (2.0)	.335 (8.5)	.047 (1.2)	.787 (20.0)	3.150 (80.0)	1.575 (40.0)
07	18, 20, 22, 24	1.693 (43.0)	1.102 (28.0)	.087 (2.2)	.394 (10.0)	.051 (1.3)	1.142 (29.0)	3.898 (99.0)	2.165 (55.0)
08	26, 28	2.362 (60.0)	1.378 (35.0)	.130 (3.3)	.591 (15.0)	.063 (1.6)	1.575 (40.0)	5.118 (130.0)	1.969 (50.0)



Labor-saving. Environmental. Shielded. Self-locking. "Piggyback" boot adapters reduce installation time compared to conventional heatshrink boots. Supplied as shown with the boot already installed on adapter. Terminate cable shield to plated brass shield termination adapter using Band-Master ATS® strap and hand tool. Boot is pre-coated with "W1" hot melt adhesive. These adapters fit Glenair Series 806 ultraminiature circular connectors.

Specifications

- Operating temperature: -55° to +125°C
- Salt spray (corrosion): 2000 hours

Construction

- Drop-in EMI adapter: brass, see ordering info for finish options
- Coupling nut, adapter: high grade engineering thermoplastic, no plating, black
- Anti-decoupling device: high grade engineering thermoplastic
- Shield termination strap: 300 series stainless steel, passivated
- O-ring: silicone
- Adhesive: W1 hot melt polyamide, 125°C max. operating temperature

How To Order					
SAMPLE PART NUMBER	317VS111	BM	12	-1	K
Product	317VS111 = Straight Adapter 317VB111 = 45° Adapter 317VA111 = 90° Adapter				
Finish	BM = Electroless nickel BMT = Nickel/PTFE BN = Olive drab cadmium BZR = Black zinc-nickel				
Shell Size	09 10 11 12 14 16 18 20 22 24				
Boot Material	1 = High performance elastomer 2 = Low smoke zero halogen polyolefin				
Optional Band Strap	Omit for no band strap. K = Adapter supplied with pre-coiled shield termination band				

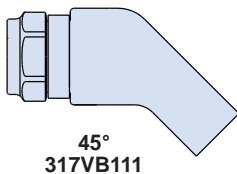

45°
317VB111

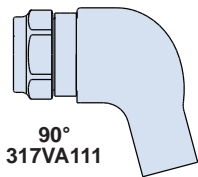

90°
317VA111

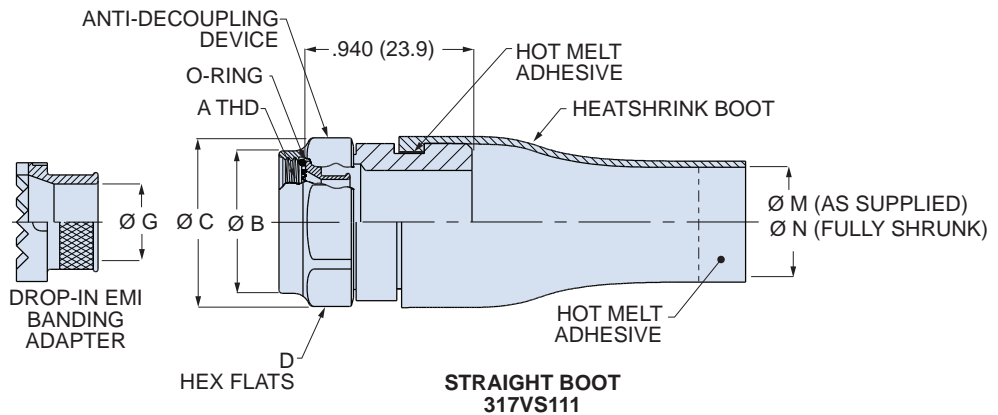

STRAIGHT BOOT
317VS111

Band Strap

Band strap can be ordered with backshell or purchased separately.



Band Strap Hand Tool

601-101

Micro Band Ordering Information

Length		Part Number	Max Diameter	
in.	mm.		in.	mm.
5.0	127	601-025	.50	12.7
8.0	203	601-061	.88	22.4
14.0	356	601-065	1.88	47.8

Table 1 Dimensions

Shell Size	A ISO Metric Thread	ØB Max.		ØC Max.		D Hex		ØG		M Min.		N Max.	
		In.	mm.	In.	mm.	In.	mm.	In.	mm.	In.	mm.	In.	mm.
09	M12 x 1.0-6H	.65	16.5	.86	21.8	.75	19.1	.178	4.5	.250	6.4	.197	5.0
10	M14 x 1.0-6H	.77	19.5	.98	24.9	.88	22.2	.295	7.5	.355	9.0	.197	5.0
11	M15 x 1.0-6H	.77	19.5	.98	24.9	.88	22.2	.305	7.7	.355	9.0	.197	5.0
12	M17 x 1.0-6H	.89	22.6	1.16	29.5	1.00	25.4	.394	10.0	.491	12.5	.236	6.0
14	M19 x 1.0-6H	1.03	26.2	1.28	32.5	1.13	28.6	.472	12.0	.565	14.4	.236	6.0
16	M22 x 1.0-6H	1.03	26.2	1.28	32.5	1.13	28.6	.565	14.4	.565	14.4	.236	6.0
18	M25 x 1.0-6H	1.15	29.2	1.41	35.8	1.25	31.8	.658	16.7	.690	17.5	.276	7.0
20	M28 x 1.0-6H	1.28	32.5	1.52	38.6	1.38	34.9	.777	19.7	.769	19.5	.335	8.5
22	M31 x 1.0-6H	1.41	35.8	1.64	41.7	1.50	38.1	.873	22.2	.894	22.7	.394	10.0
24	M34 x 1.0-6H	1.53	38.9	1.77	45.0	1.63	41.3	.997	25.3	1.019	25.9	.394	10.0

Series 806

Mighty Mouse Mil-Aero Connectors

457-048 Composite EMI/RFI Qwik-Ty® Strain Relief



Low profile. Light weight. Band-Master ATS® shield termination. Self-locking.

Next-generation Qwik-Ty® features high strength composite construction plus EMI shielding. Available in straight, 45° or 90° versions. Terminate cable shield to plated brass shield termination adapter using Band-Master ATS® strap and hand tool. Attach wire bundle to arm with MS3367-type nylon tie strap (not supplied). Optional rubber pad provides wire cushioning. Slots in shield adapter accept individual shields.

Specifications

- Operating temperature: -65° to +200°C (Finish code BN is +175°C)
- Salt spray (corrosion): 2000 hours

Construction

- Drop-in EMI adapter: brass, see ordering info for finish options
- Coupling nut, Qwik-Ty body: high grade engineering thermoplastic, no plating, black
- Anti-decoupling device: high grade engineering thermoplastic
- Shield termination strap: 300 series stainless steel, passivated (not supplied)
- Pad: green fluorosilicone

How To Order

SAMPLE PART NUMBER		457VS048	BM	16
Product		457VS048 = Straight 457VB048 = 45° 457VA048 = 90°		
Finish		BM = Electroless nickel BMT = Nickel/PTFE BN = Olive drab cadmium BZR = Black zinc-nickel		
Shell Size		09 10 11 12 14 16 18 20 22 24		
Optional Rubber Pad		Omit for no rubber pad. P = Supplied with rubber pad (687-038)		

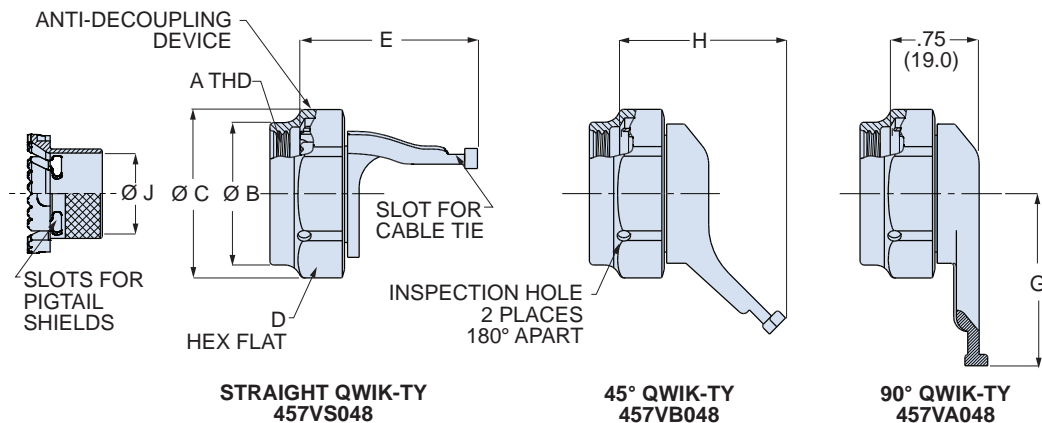
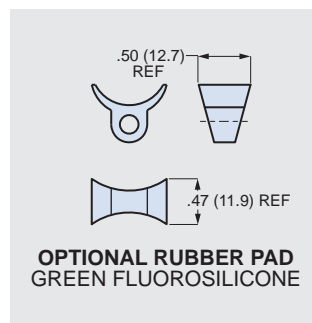

Band Strap

Band strap is purchased separately.



Micro Band Strap Hand Tool

601-101

Micro Band Ordering Information

Length		Part Number	Max Diameter	
in.	mm.		in.	mm.
5.0	127	601-025	.50	12.7
8.0	203	601-061	.88	22.4
14.0	356	601-065	1.88	47.8

Dimensions

Shell Size	A ISO Metric Thread	ØB Max.		ØC Max.		D Hex		E Max.		G Max.		H Max.		J	
		In.	mm.	In.	mm.	In.	mm.	In.	mm.	In.	mm.	In.	mm.		
09	M12 x 1.0-6H	.65	16.5	.86	21.8	.75	19.1	1.28	32.5	1.22	31.0	1.14	29.0	.178	4.5
10	M14 x 1.0-6H	.77	19.5	.98	24.9	.88	22.2	1.28	32.5	1.29	32.8	1.14	29.0	.295	7.5
11	M15 x 1.0-6H	.77	19.5	.98	24.9	.88	22.2	1.28	32.5	1.29	32.8	1.14	29.0	.305	7.7
12	M17 x 1.0-6H	.89	22.6	1.16	29.5	1.00	25.4	1.44	36.6	1.62	41.1	1.14	29.0	.394	10.0
14	M19 x 1.0-6H	1.03	26.2	1.28	32.5	1.13	28.6	1.51	38.4	1.66	42.2	1.64	41.7	.472	12.0
16	M22 x 1.0-6H	1.03	26.2	1.28	32.5	1.13	28.6	1.51	38.4	1.66	42.2	1.64	41.7	.565	14.4
18	M25 x 1.0-6H	1.15	29.2	1.41	35.8	1.25	31.8	1.51	38.4	1.72	43.7	1.64	41.7	.658	16.7
20	M28 x 1.0-6H	1.28	32.5	1.52	38.6	1.38	34.9	1.57	39.9	1.72	43.7	1.74	44.2	.777	19.7
22	M31 x 1.0-6H	1.41	35.8	1.64	41.7	1.50	38.1	1.71	43.4	1.79	45.5	1.74	44.2	.873	22.2
24	M34 x 1.0-6H	1.53	38.9	1.77	45.0	1.63	41.3	1.83	46.5	1.85	47.0	1.74	44.2	.997	25.3

Series 806

Mighty Mouse Mil-Aero Connectors

4470-1061 Composite EMI/RFI Band-in-a-Can Backshell



Corrosion-resistant. Self-locking. Shielded. Saddle clamp. Band termination.

EMI/RFI "band-in-a-can" backshell fits Series 806 connectors. Terminate cable shield to backshell with optional **Band-Master ATS®** stainless steel band. Coupling nut and cable clamp are black composite material, adapter is plated with conductive nickel, nickel-PTFE or olive drab cadmium. Non-environmental. Straight, 45° or 90°.

Specifications

- Operating temperature: codes XM, XMT: -65°C to +200°C code XW: -65°C to +175°C
- Salt spray (corrosion): 2000 hours

Construction

- Coupling nut, cable clamp, thread ring: high grade engineering thermoplastic, no plating, black
- Adapter body: high grade engineering thermoplastic, see ordering information for finish options.
- Hardware: 300 series stainless steel
- Anti-decoupling device: thermoplastic
- Band strap: stainless steel, passivated

How To Order						
SAMPLE PART NUMBER	4470VS1061	XM	10	12	B	S
Product	4470VS1061 = Straight Backshell 4470VT1061 = 45° Backshell 4470VW1061 = 90° Backshell					
Finish	XM = Electroless nickel XMT = Nickel/PTFE XW = Olive Drab Cadmium					
Shell Size	08 09 10 11 12 14 16 18 20 22 24					
Entry Code	See Table 1 for cable entry codes					
Band Option	Omit for none. B = Band (601-040) K = Pre-coiled band (601-041)					
Slot Option	Omit for none. S = slotted band platform for pigtail braid termination					

Band-Master Bands and Tool

Band strap can be ordered with backshell or purchased separately.



Standard Band Ordering Information

Length		Part Number		Max Dia.	
in.	mm.	Flat	Pre-Coiled	in.	mm.
9.0	229	601-005	601-006	1.0	25
14.0	356	601-040	601-041	1.8	48
18.0	457	601-049	601-050	2.5	64

Band Strap Hand Tool

601-100

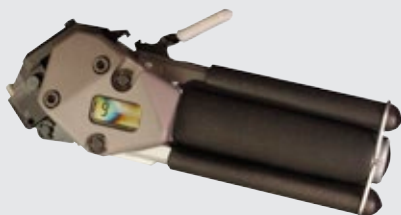
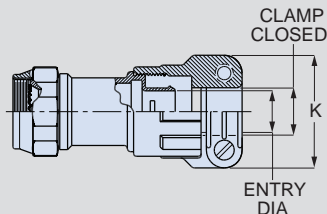
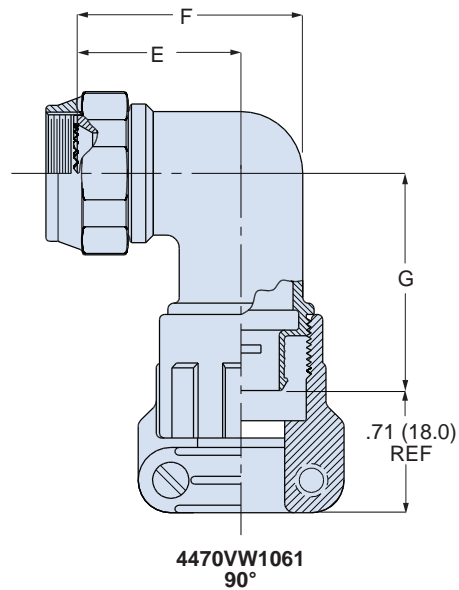
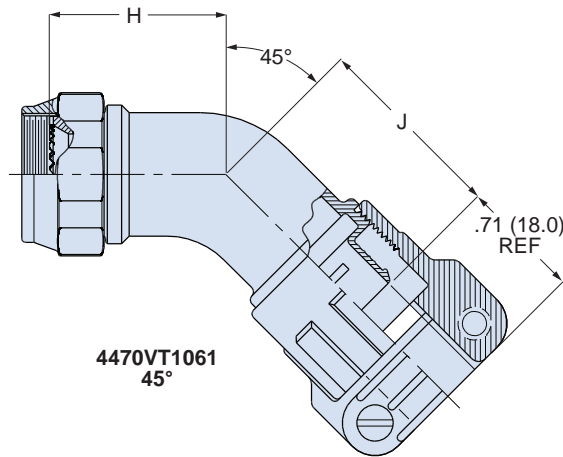
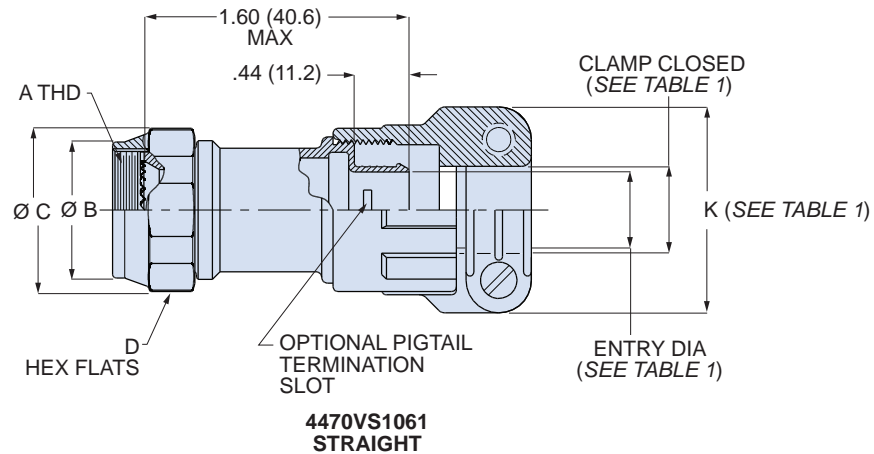

Table 1 Entry Code

Entry Code	Shell Size	Entry Dia. ± .03 (0.8)		Clamp Closed ± .03 (0.8)		K ± .06 (1.5)	
		In.	mm.	In.	mm.	In.	mm.
10	08 thru 24	.22	5.6	.26	6.6	.94	23.9
12	10 thru 24	.28	7.1	.34	8.6	1.17	29.7
14	12 thru 24	.34	8.6	.46	11.7	1.28	32.5
16	14 thru 24	.46	11.7	.55	14.0	1.41	35.8
18	18 thru 24	.55	14.0	.62	15.7	1.50	38.1
20	18 thru 24	.62	15.7	.70	17.8	1.56	39.6
22	22, 24	.70	17.8	.78	19.8	1.69	42.9
24	24	.78	19.8	.85	21.6	1.81	46.0





Dimensions

Shell Size	Max Entry Code	A ISO Metric Thread	ØB Max.		ØC Max.		D Hex		E ±.06 (1.5)		F ±.09 (2.3)		G Max.		H ±.06 (1.5)		J ±.09 (2.3)	
			In.	mm.	In.	mm.	In.	mm.	In.	mm.	In.	mm.	In.	mm.	In.	mm.	In.	mm.
08	10	M10 x 1.0-6H	.65	16.5	.86	21.8	.75	19.1	.69	17.5	.88	22.4	1.31	33.3	.72	18.3	1.15	29.2
09	10	M12 x 1.0-6H	.65	16.5	.86	21.8	.75	19.1	.69	17.5	.88	22.4	1.31	33.3	.72	18.3	1.15	29.2
10	12	M14 x 1.0-6H	.77	19.6	.98	24.9	.88	22.2	.75	19.1	1.00	25.4	1.42	36.1	.75	19.1	1.27	32.3
11	12	M15 x 1.0-6H	.77	19.6	.98	24.9	.88	22.2	.75	19.1	1.00	25.4	1.42	36.1	.75	19.1	1.27	32.3
12	14	M17 x 1.0-6H	.89	22.6	1.16	29.5	1.00	25.4	.81	20.6	1.13	28.7	1.57	39.9	.75	19.1	1.33	33.8
14	16	M19 x 1.0-6H	1.03	26.2	1.28	32.5	1.13	28.6	.88	22.4	1.31	33.3	1.57	39.9	.76	19.3	1.37	34.8
16	16	M22 x 1.0-6H	1.03	26.2	1.28	32.5	1.13	28.6	.88	22.4	1.31	33.3	1.57	39.9	.76	19.3	1.37	34.8
18	20	M25 x 1.0-6H	1.15	29.2	1.41	35.8	1.25	31.8	.94	23.9	1.38	35.1	1.64	41.7	.78	19.8	1.39	35.3
20	20	M28 x 1.0-6H	1.28	32.5	1.52	38.6	1.38	34.9	.97	24.6	1.44	36.6	1.73	43.9	.79	20.1	1.41	35.8
22	22	M31 x 1.0-6H	1.41	35.8	1.64	41.7	1.50	38.1	1.06	26.9	1.63	41.4	1.82	46.2	.82	20.8	1.43	36.3
24	24	M34 x 1.0-6H	1.53	38.9	1.77	45.0	1.63	41.3	1.13	28.7	1.75	44.5	1.82	46.2	.86	21.8	1.47	37.3



EMI shielding. Band-Master ATS® shield termination. Self-locking. Environmental. Spin coupling EMI/RFI backshell with anti-decoupling ratchet prevents loosening under vibration. Fits Series 806 connectors. Terminate cable shield to backshell with **Band-Master ATS®** stainless steel band, supplied with backshell. Cable clamp grommet provides environmental seal to cable jacket. Straight, 45° or 90° cable exit. Aluminum or stainless steel.

Features

- EMI/RFI
- Self-locking spin coupling
- Supplied with MicroBand shield termination band
- Environmental

Specifications

- Operating temperature:
codes ME, MT and Z1: -65°C to +200°C
codes ZR, NF, NFP: -65°C to +175°C
- Shell conductivity:
aluminum versions: 2.5 milliohms max.
Stainless steel: 5 milliohms max.
- Salt spray (corrosion)
Code ME, NFP: 96 hours
Code NF, ZR, MT, Z1: 1000 hours
- Vibration: SAE AS85049 Category 3B
- Shock: SAE AS85049 Category 3B

Construction

- Coupling nut, adapter, saddle bars, cable clamp: aluminum alloy or 300 series stainless steel. See material/finish options in How to Order table for options.
- O-rings, grommet: silicone
- Hardware: 300 series stainless steel
- Anti-decoupling device: corrosion-resistant material
- Band strap: stainless steel, passivated

How To Order					
SAMPLE PART NUMBER	443VS039	MT	08	01	-2
Product	443VS039 = Straight Backshell 443VH039 = 45° Backshell 443VJ039 = 90° Backshell				
Material/ Finish	ME = Aluminum, Electroless Nickel MT = Aluminum, Ni/PTFE ZR = Aluminum, Black Zinc-Nickel NF = Aluminum, Olive Drab Cadmium NFP = Aluminum, Olive Drab Cadmium, nickel-plated shield termination area, polysulfide barrier Z1 = Stainless Steel, Passivated				
Shell Size	08 09 10 11 12 14 16 18 20 22 24				
Cable Entry Code	See Table 1 for cable entry sizes				
Adapter Length	Omit for 45° and 90° versions. Applicable to 443VS039 only. Length in ½ inch increments. 2 = 1 inch (min. for Style 1) 3 = 1½ inches 4 = 2 inches (min. for Style 2) 5 = 2½ inches 6 = 3 inches				

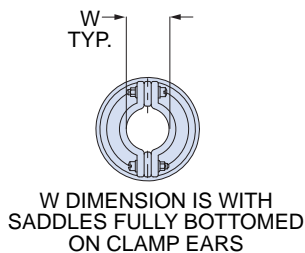
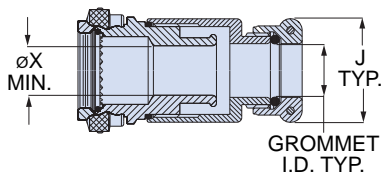
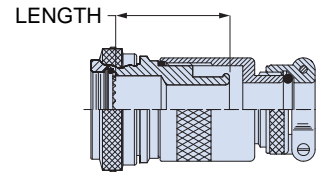
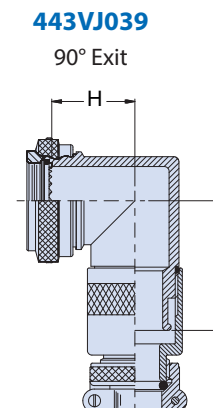
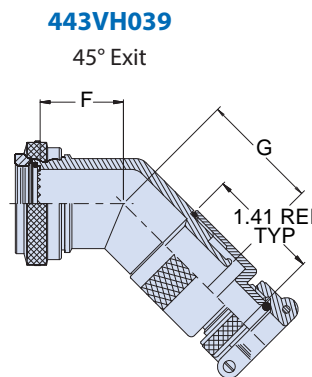
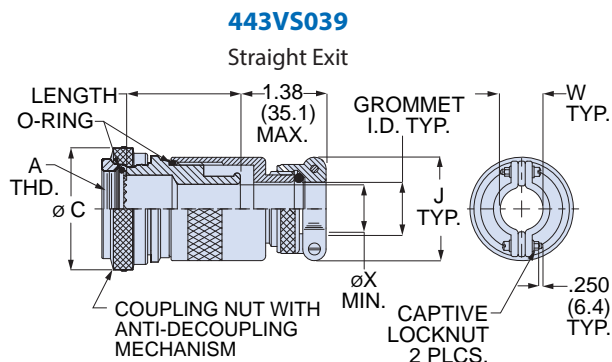

Table 1 Cable Entry

Cable Entry Code	Grommet Diameter		J Max.		W Closed		ø X Min.			
	Min. In.	Max. mm.	Min. In.	Max. mm.	Min. In.	Max. mm.	Min. In.	Max. mm.		
01	.125	3.18	.250	6.35	1.05	26.7	.264	6.71	.25	6.4
02	.188	4.78	.375	9.53	1.20	30.5	.344	8.74	.37	9.4
03	.312	7.92	.438	11.13	1.30	33.0	.460	11.68	.43	10.9
04	.343	8.71	.500	12.70	1.44	36.6	.545	13.84	.50	12.7
05	.438	11.13	.625	15.88	1.69	42.9	.698	17.73	.62	15.7
06	.562	14.27	.750	19.05	1.77	45.0	.780	19.81	.75	19.1
07	.688	17.48	.875	22.23	2.12	53.8	.950	24.13	.87	22.1
08	.812	20.62	1.000	25.40	2.50	63.5	1.015	25.78	1.00	25.4
09	.938	23.83	1.125	28.58	2.62	66.5	1.187	30.15	1.12	28.4
10	1.062	26.97	1.250	31.75	2.68	68.1	1.220	30.99	1.25	31.8
11	1.125	28.58	1.375	34.93	3.00	76.2	1.500	38.10	1.38	35.1
12	1.250	31.75	1.500	38.10	3.50	88.9	1.625	41.28	1.50	38.1



Shell Size	A ISO Metric Thread	øC Max.		F Max. ⁽¹⁾		G Max.		H Max. ⁽¹⁾		J Max.		Max. Cable Entry Code ⁽¹⁾
		In.	mm.	In.	mm.	In.	mm.	In.	mm.	In.	mm.	
08	M10 x 1.0-6H	.692	17.58	.630	16.00	1.030	26.16	.880	22.35	1.180	29.97	01
09	M12 x 1.0-6H	.786	19.96	.640	16.26	1.030	26.16	.880	22.35	1.210	30.73	01
10	M14 x 1.0-6H	.883	22.43	.670	17.02	1.060	26.92	.930	23.62	1.260	32.00	02
11	M15 x 1.0-6H	.911	23.14	.680	17.27	1.090	27.69	.980	24.89	1.290	32.77	03
12	M17 x 1.0-6H	1.002	25.45	.700	17.78	1.100	27.94	.990	25.15	1.320	33.53	04
14	M19 x 1.0-6H	1.066	27.08	.720	18.29	1.100	27.94	.990	25.15	1.350	34.29	04
16	M22 x 1.0-6H	1.196	30.38	.760	19.30	1.130	28.70	1.050	26.67	1.410	35.81	05
18	M25 x 1.0-6H	1.311	33.30	.790	20.07	1.170	29.72	1.120	28.45	1.470	37.34	06
20	M28 x 1.0-6H	1.430	36.32	.830	21.08	1.200	30.48	1.180	29.97	1.530	38.86	07
22	M31 x 1.0-6H	1.548	39.32	.860	21.84	1.240	31.50	1.240	31.50	1.590	40.39	08
24	M34 x 1.0-6H	1.696	43.08	.910	23.11	1.290	32.77	1.300	33.02	1.670	42.42	09

(1) If the maximum cable entry code is exceeded, the backshell will be a "Style 2" with a transition adapter as shown below. The F and H dimensions will be increased by 0.9 inch (22.9 mm.) maximum.

Style 2 Adapters for Large Diameter Cables

If the cable entry diameter exceeds the maximum cable entry code shown in the above table, the adapter will be supplied with a **transition adapter**. On straight exit backshells, the transition adapter does not affect the length. On 45° and 90° versions the transition adapter adds 0.9 inch (22.9 mm) maximum to the backshell length.

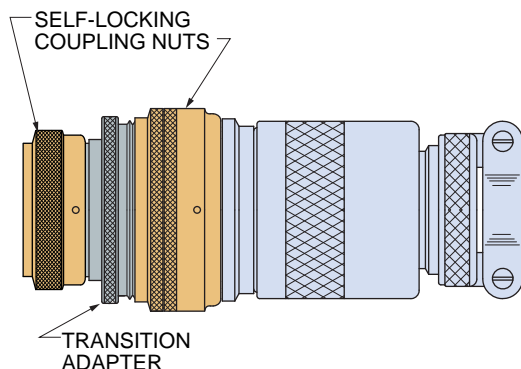

Application Note: Selective Plated Cadmium with Polysulfide Barrier

Olive drab (OD) cadmium (Cd) over electroless nickel (EN) is available in two versions. The standard version, designated as Glenair code **NF**, is a uniform Cd/EN finish over the entire part. A second version, designated as Glenair code **NFP**, is selectively plated with electroless nickel in the knurled shield attachment area. A polysulfide barrier separates the electroless nickel area from the cadmium plated area. This selectively plated version prevents galvanic corrosion that could potentially occur if nickel-coated shield braid is attached to a cadmium plated surface.

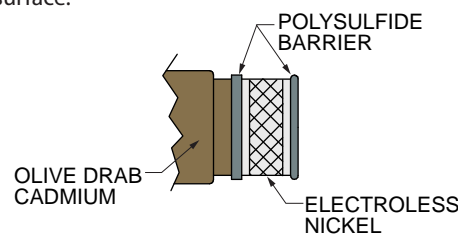



Strain relief clamp with anti-decoupling ratchet prevents loosening under vibration. Full radius saddle clamps prevent pinching of cables. Fits Series 806 connectors. Straight, 45° or 90° cable exit.

How To Order			
SAMPLE PART NUMBER	620VS080	MT	08
Product	620VS080 = Straight Strain Relief 620VB080 = 45° Strain Relief 620VA080 = 90° Strain Relief		
Material/ Finish	ME = Aluminum, Electroless Nickel MT = Aluminum, Ni/PTFE ZR = Aluminum, Black Zinc-Nickel NF = Aluminum, Olive Drab Cadmium Z1 = Stainless Steel, Passivated		
Shell Size	08 09 10 11 12 14 16 18 20 22 24		

Features

- Straight, 45° and 90°
- Self-locking spin coupling
- Fits Series 806 ultraminiature connectors
- Captive threaded inserts

Specifications

- Operating temperature: codes ME, MT and Z1: -65°C to +200°C
codes ZR, NF, NFP: -65°C to +175°C
- Salt spray (corrosion)
Code ME: 96 hours
Code NF, ZR, MT, Z1: 1000 hours
- Vibration, shock: SAE AS85049 Category 4C

Construction

- Clamp, body, saddles, coupling nut: aluminum alloy or 300 series stainless steel. See material/finish options in How to Order table for options.
- Hardware: 300 series stainless steel
- Anti-decoupling device: corrosion-resistant material

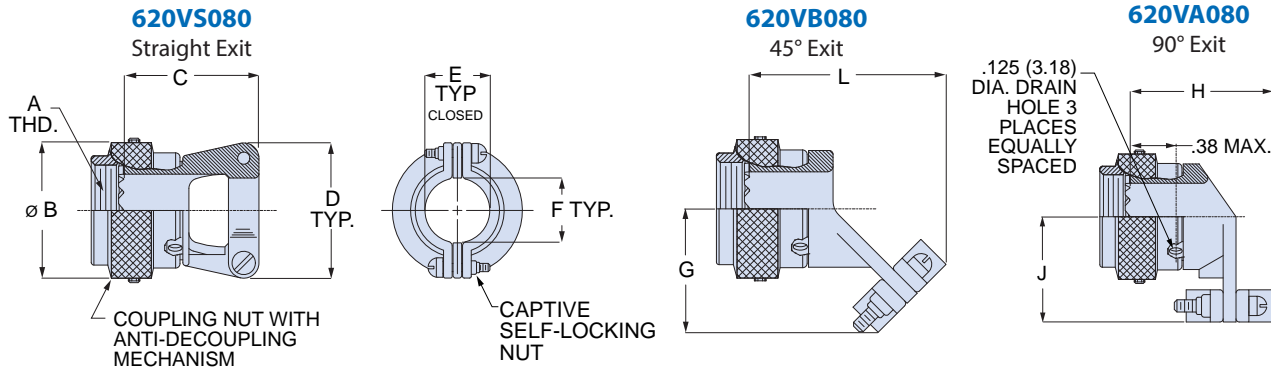

Shell Size	A ISO Metric Thread	øB Max.		C Max.		D Max.		E ±.031 (0.79)		F Min.		G Max.		H Max.		J Max.		L Max.	
		In.	mm.	In.	mm.	In.	mm.	In.	mm.	In.	mm.	In.	mm.	In.	mm.	In.	mm.	In.	mm.
08	M10 x 1.0-6H	.642	16.31	.710	18.03	.93	23.3	.205	5.21	.18	4.6	.891	22.63	1.04	26.42	.87	22.10	1.30	33.02
09	M12 x 1.0-6H	.735	18.67	.840	21.34	.98	24.9	.219	5.56	.22	5.6	.901	22.89	1.06	26.92	.91	23.11	1.32	33.53
10	M14 x 1.0-6H	.786	19.96	.900	22.86	1.02	25.9	.244	6.20	.25	6.4	.945	24.00	1.08	27.43	.95	24.13	1.35	34.29
11	M15 x 1.0-6H	.830	21.08	.960	24.38	1.05	26.7	.264	6.71	.27	6.9	.964	24.49	1.10	27.94	.97	24.64	1.36	34.54
12	M17 x 1.0-6H	.911	23.14	1.060	26.92	1.12	28.5	.312	7.92	.32	8.1	1.030	26.16	1.15	29.21	1.03	26.16	1.41	35.81
14	M19 x 1.0-6H	1.002	25.45	1.100	27.94	1.20	30.5	.344	8.74	.35	8.9	1.050	26.67	1.18	29.97	1.06	26.92	1.43	36.32
16	M22 x 1.0-6H	1.149	29.18	1.100	27.94	1.30	33.0	.460	11.68	.47	11.9	1.112	28.24	1.30	33.02	1.16	29.46	1.48	37.59
18	M25 x 1.0-6H	1.264	32.11	1.230	31.24	1.44	36.6	.545	13.84	.55	14.0	1.175	29.85	1.38	35.05	1.34	34.04	1.58	40.13
20	M28 x 1.0-6H	1.394	35.41	1.410	35.81	1.56	39.6	.615	15.62	.62	15.7	1.230	31.24	1.46	37.08	1.41	35.81	1.70	43.18
22	M31 x 1.0-6H	1.513	38.43	1.510	38.35	1.69	42.9	.698	17.73	.70	17.8	1.293	32.84	1.58	40.13	1.53	38.86	1.74	44.20
24	M34 x 1.0-6H	1.631	41.43	1.660	42.16	1.77	45.0	.780	19.81	.78	19.8	1.365	34.67	1.62	41.15	1.66	42.16	1.79	45.47



Spin coupling shorting cap fits Series 806 connectors with metric accessory thread. Available with lanyard attachments. Aluminum.

Features

- Spin coupling, environmental
- Wire rope, sash chain or braided nylon lanyards

Specifications

- Operating temperature:
codes ME, MT: -65°C to +200°C
codes ZR, NF: -65°C to +175°C
- Salt spray (corrosion)
Code ME: 96 hours
Code NF, ZR, MT: 1000 hours

Construction

- Coupling nut, shell: aluminum alloy.
- O-ring: silicone
- Attachment hardware: stainless steel, passivated

Table 1 Attachment Type



Nylon Rope (G)

-55° to +100°C, black, very flexible, very good abrasion resistance, good resistance to fuels, .120" (3mm) diameter



Polyurethane Coated Wire Rope (U)

Black polyurethane over stainless steel rope, -55° to +125°C, very flexible, excellent abrasion resistance, excellent resistance to fuels, .080" (2mm) diameter



Teflon® Jacketed Wire Rope (H)

Translucent FEP jacket over stainless steel, -55° to +200°C, fair flexibility, good abrasion resistance, .100" diameter

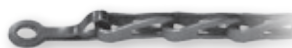

Sash Chain (S)

Stainless steel, #8 chain, .240" (6mm)

How To Order							
SAMPLE PART NUMBER	340VS035	ME	12	-3	S	12	-04
Product	340VS035 = Shorting Cap, straight, for Series 806 connectors						
Finish	ME = Aluminum, Electroless Nickel MT = Aluminum, Ni/PTFE ZR = Aluminum, Black Zinc-Nickel NF = Aluminum, Olive Drab Cadmium						
Shell Size	08 09 10 11 12 14 16 18 20 22 24						
Length	Length in ¼ inch increments. ¾ inch minimum. 3 = .75 inches (minimum) 8 = 2 inches 4 = 1 inch 9 = 2.25 inches 5 = 1.25 inches 10 = 2.5 inches 6 = 1.5 inches 12 = 3 inches 7 = 1.75 inches 16 = 4 inches						
Attachment Type (Table I)	N = No attachment G = Nylon rope U = SST rope with polyurethane coating H = SST rope with high temperature translucent FEP jacket S = Sash chain, #8, SST						
Attachment Length	Omit for attachment type N (no attachment) Lanyard length in ½ inch increments. e.g. 12 = 6 inches, 16 = 8 inches						
Attachment Ring Inside Diameter	Omit for attachment type N (no attachment) 04 = .126 (3.20) diameter 06 = .145 (3.68) diameter 08 = .188 (4.78) diameter 10 = .197 (5.00) diameter						

Shell Size	A ISO Metric Thread	øB Max.	
		In.	mm.
08	M10 x 1.0-6H	.570	14.48
09	M12 x 1.0-6H	.650	16.51
10	M14 x 1.0-6H	.750	19.05
11	M15 x 1.0-6H	.790	20.07
12	M17 x 1.0-6H	.870	22.10
14	M19 x 1.0-6H	.950	24.13
16	M22 x 1.0-6H	1.070	27.18
18	M25 x 1.0-6H	1.180	29.97
20	M28 x 1.0-6H	1.300	33.02
22	M31 x 1.0-6H	1.420	36.07
24	M34 x 1.0-6H	1.540	39.12

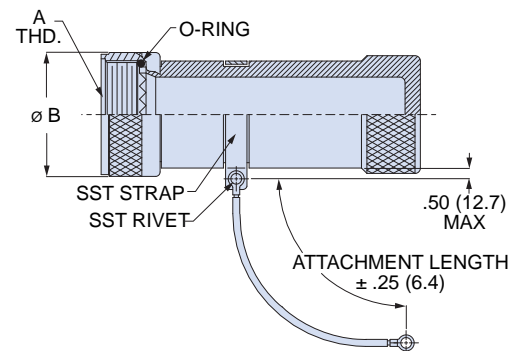

Arrangement No. 8-3

3 #20HD Contacts

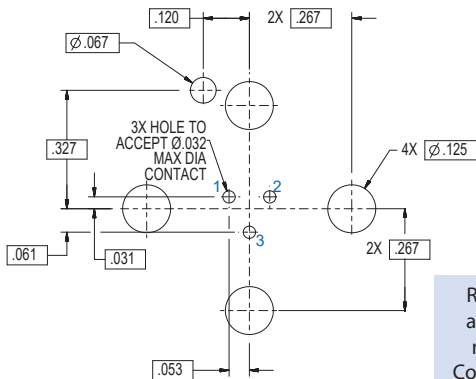

Arrangement No. 8-4

4 #22HD Contacts

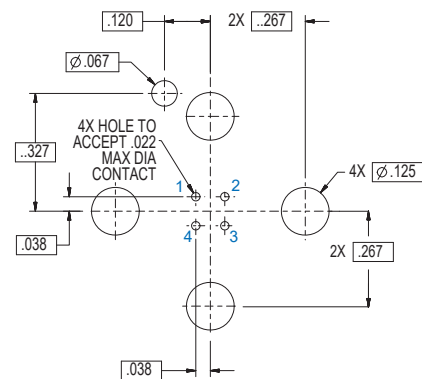

Arrangement No. 8-7

7 #22HD Contacts

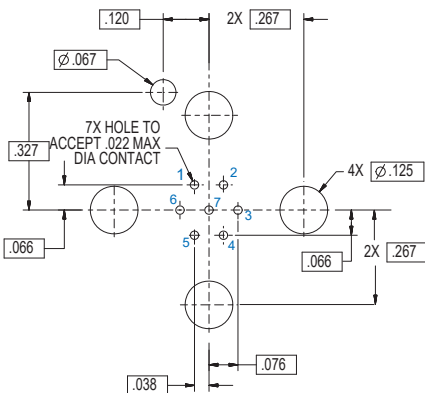

Arrangement No. 9-5

5 #20HD Contacts

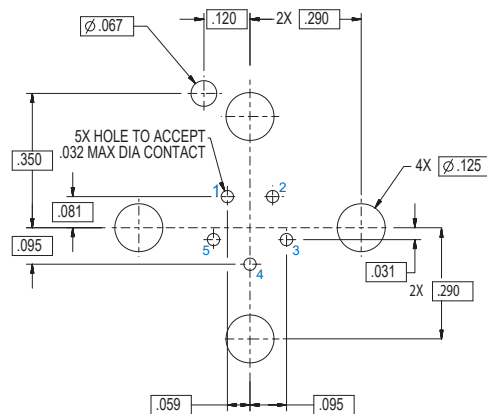

Arrangement No. 9-11

11 #22HD Contacts

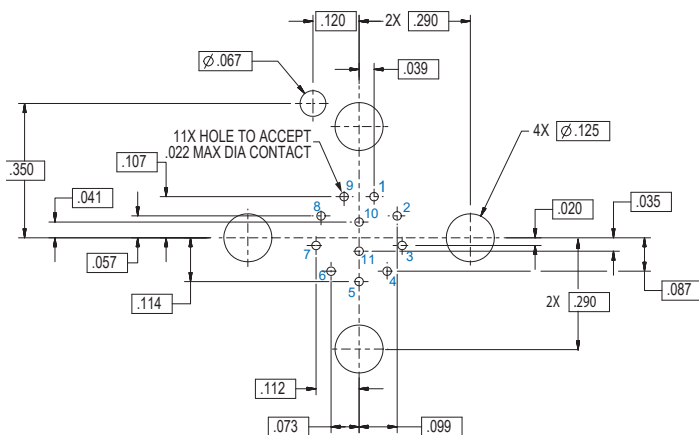

Arrangement No. 10-8

8 #20HD Contacts

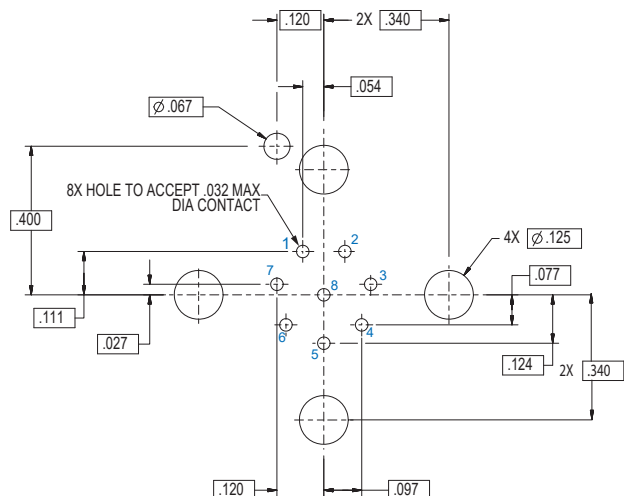

Recommended PCB Layouts are shown for the connector mounting size of PC board. Contact identification numbers are for pin connectors. Socket identification numbers are reversed.

Series 806 Mighty Mouse Mil-Aero Connectors



PC Board Layouts for 806-021, 806-022, 806-026, 806-028, 240-806-21

Recommended PCB Layouts are shown for the connector mounting size of PC board. Contact identification numbers are for pin connectors. Socket identification numbers are reversed.

Arrangement No. 10-15
15 #22HD Contacts

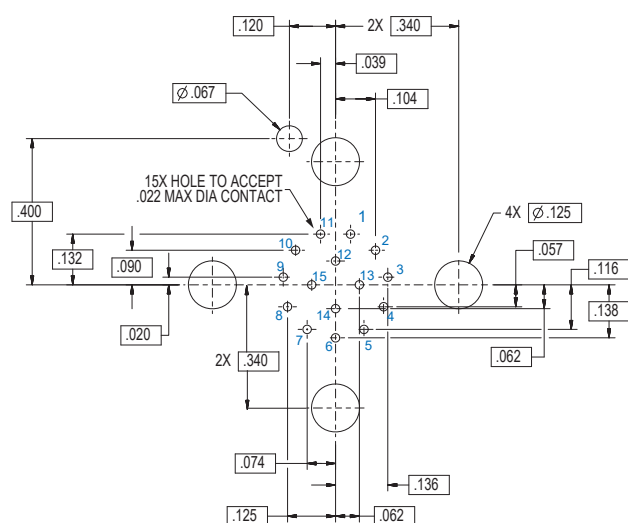

Arrangement No. 11-10
10 #20HD Contacts

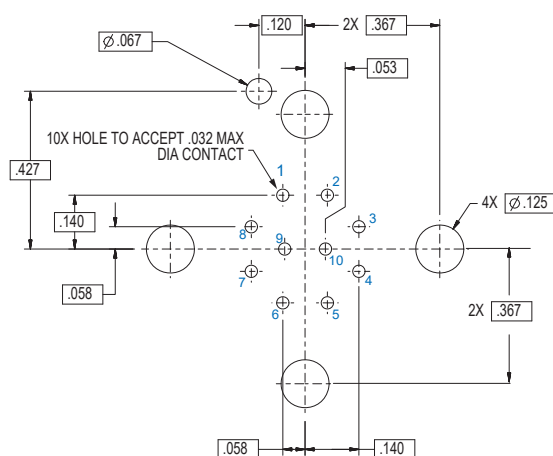

Arrangement No. 11-19
19 #22HD Contacts

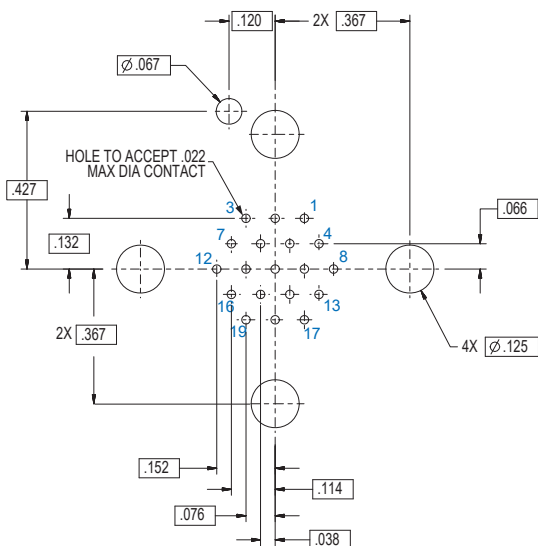

Arrangement No. 12-15
15 #20HD Contacts

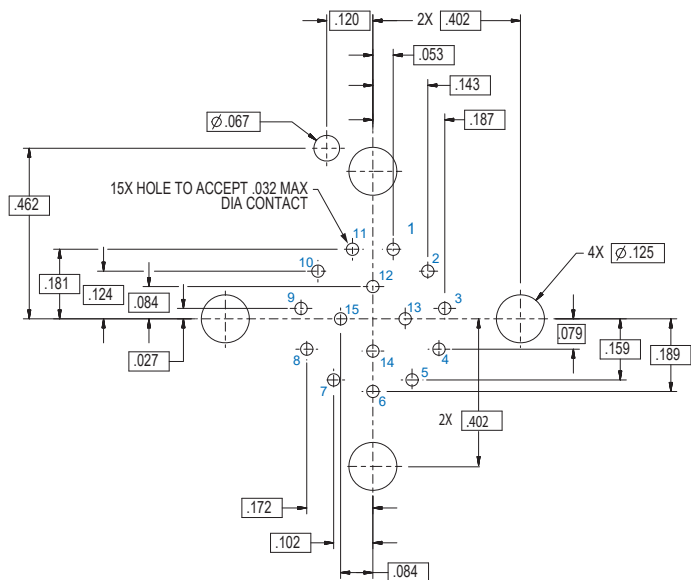

Recommended PCB Layouts are shown for the connector mounting size of PC board. Contact identification numbers are for pin connectors. Socket identification numbers are reversed.

Arrangement No. 12-26
26 #22HD Contacts

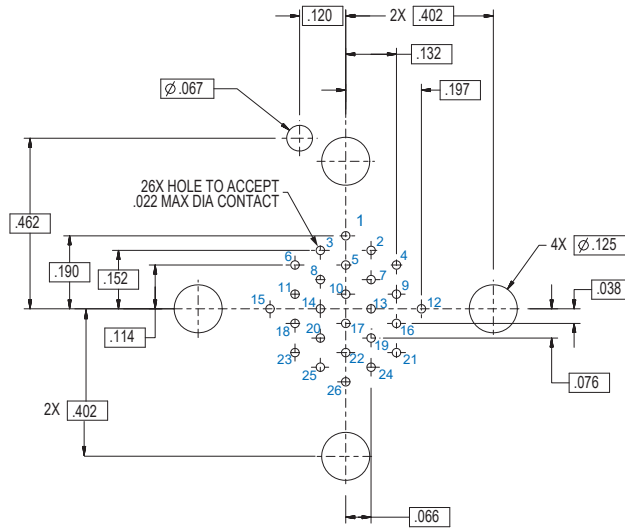

Arrangement No. 14-20
20 #20HD Contacts

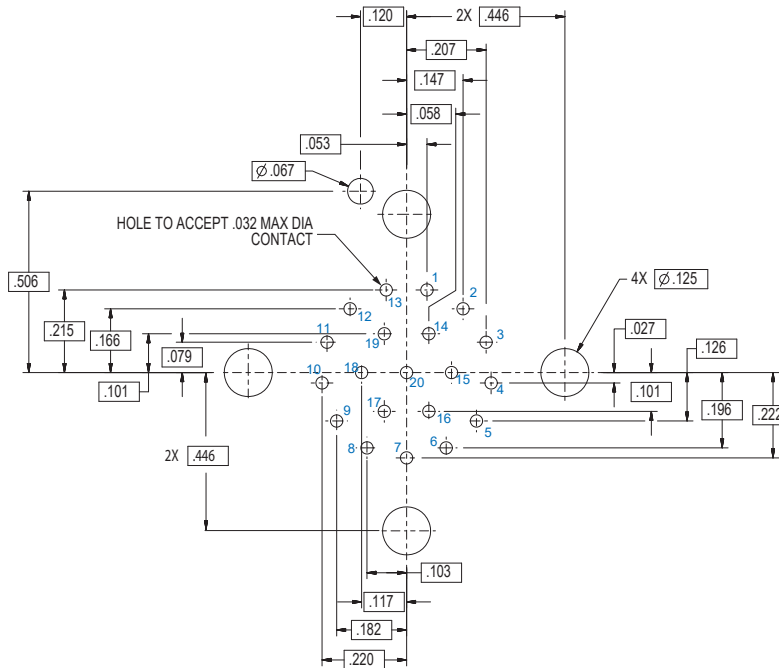



Recommended PCB Layouts are shown for the connector mounting size of PC board. Contact identification numbers are for pin connectors. Socket identification numbers are reversed.

Arrangement No. 14-39
39 #22HD Contacts

Contact Position ID	Location		Contact Position ID	Location	
	X Axis	Y Axis		X Axis	Y Axis
1	.039	.232	21	.106	.119
2	.112	.207	22	.149	.057
3	.173	.160	23	.158	-.019
4	.216	.095	24	.131	-.091
5	.235	.019	25	.074	-.141
6	.228	-.058	26	.000	-.160
7	.197	-.129	27	-.074	-.141
8	.145	-.186	28	-.131	-.091
9	.077	-.223	29	-.158	-.019
10	.000	-.236	30	-.149	.057
11	-.077	-.223	31	-.106	.119
12	-.145	-.186	32	-.038	.155
13	-.197	-.129	33	.042	.072
14	-.228	-.058	34	.084	.000
15	-.235	.019	35	.042	-.072
16	-.216	.095	36	-.042	-.072
17	-.173	.160	37	-.084	.000
18	-.112	.207	38	-.042	.072
19	-.039	.232	39	.000	.000
20	.038	.155			

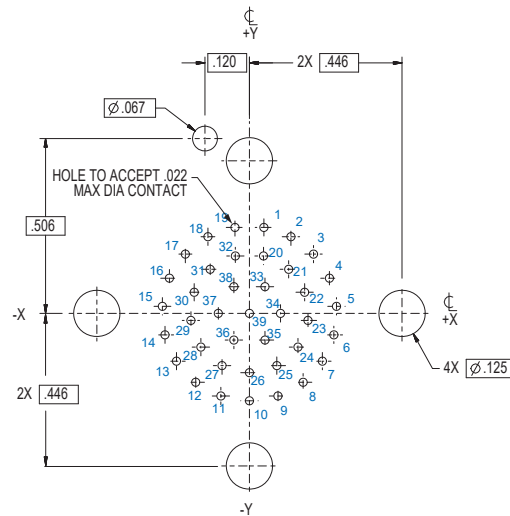

Arrangement No. 16-31
31 #20HD Contacts

Contact Position ID	Location		Contact Position ID	Location	
	X Axis	Y Axis		X Axis	Y Axis
1	.053	.283	17	-.053	.283
2	.152	.245	18	.057	.174
3	.230	.174	19	.148	.108
4	.277	.079	20	.183	.000
5	.287	-.027	21	.148	-.108
6	.258	-.128	22	.057	-.174
7	.194	-.213	23	-.057	-.174
8	.104	-.269	24	-.148	-.108
9	.000	-.288	25	-.183	.000
10	-.104	-.269	26	-.148	.108
11	-.194	-.213	27	-.057	.174
12	-.258	-.128	28	.000	.078
13	-.287	-.027	29	.078	.000
14	-.277	.079	30	.000	-.078
15	-.230	.174	31	-.078	.000
16	-.152	.245			

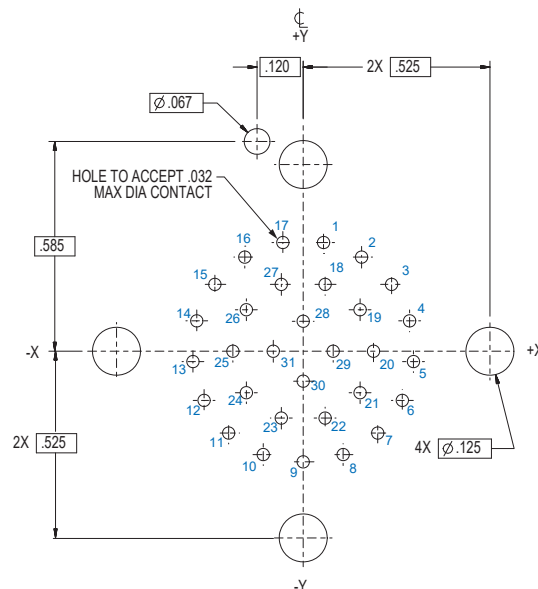

Recommended PCB Layouts are shown for the connector mounting size of PC board. Contact identification numbers are for pin connectors. Socket identification numbers are reversed.

Arrangement No. 16-60
60 #22HD Contacts

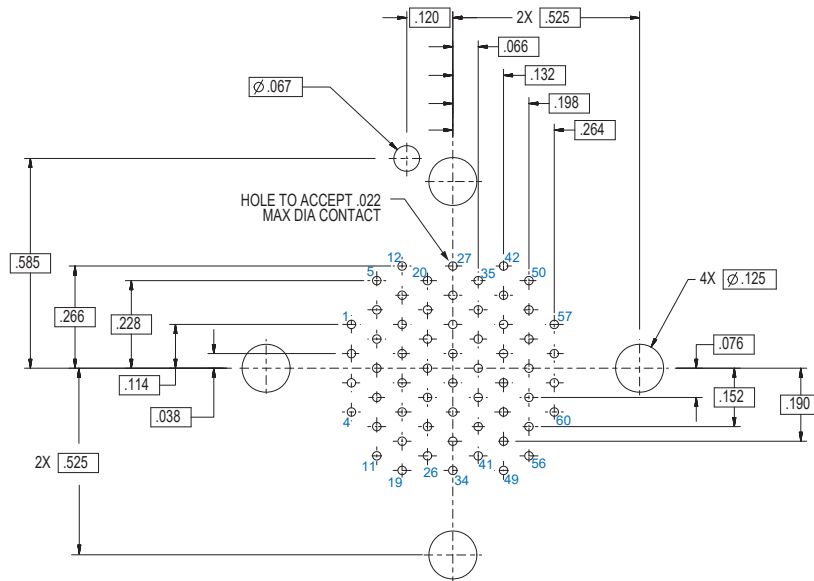

Arrangement No. 18-41
41 #20HD Contacts

Contact Position ID	Location		Contact Position ID	Location	
	X Axis	Y Axis		X Axis	Y Axis
1	.053	.336	22	.156	.176
2	.155	.303	23	.220	.083
3	.241	.241	24	.234	-.028
4	.303	.155	25	.194	-.134
5	.336	.053	26	.109	-.209
6	.336	-.053	27	.000	-.236
7	-.303	.155	28	-.109	-.209
8	-.241	.241	29	-.194	-.134
9	-.155	.303	30	-.234	-.028
10	.053	-.336	31	-.220	.083
11	-.053	-.336	32	-.156	.176
12	-.155	-.303	33	-.056	.229
13	-.241	-.241	34	.057	.118
14	-.303	-.155	35	.127	.029
15	-.336	-.053	36	.102	-.081
16	-.336	.053	37	.000	-.130
17	-.303	.155	38	-.102	-.081
18	-.241	.241	39	-.127	.029
19	-.155	.303	40	-.057	.118
20	-.053	.336	41	.000	.000
21	.056	.229			

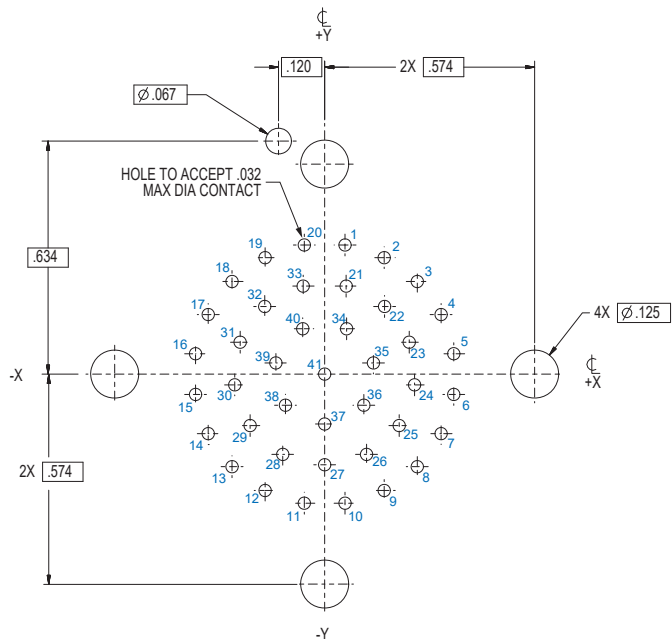



Recommended PCB Layouts are shown for the connector mounting size of PC board. Contact identification numbers are for pin connectors. Socket identification numbers are reversed.

Arrangement No. 18-85

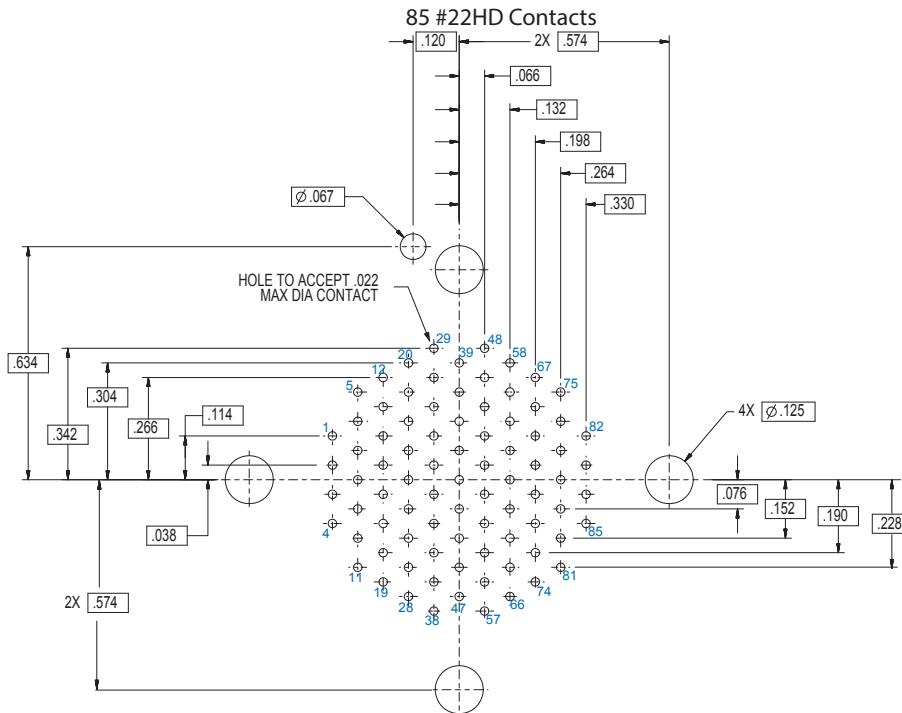

Arrangement No. 20-55

55 #20HD Contacts

Contact Pos. ID	Location X Axis	Location Y Axis	Contact Pos. ID	Location X Axis	Location Y Axis	Contact Pos. ID	Location X Axis	Location Y Axis
1	.055	.400	20	-.330	.233	39	-.157	.254
2	.161	.370	21	-.255	.313	40	-.055	.293
3	.255	.313	22	-.161	.370	41	.055	.186
4	.330	.233	23	-.055	.400	42	.146	.127
5	.380	.135	24	.055	.293	43	.192	.028
6	.403	.028	25	.157	.254	44	.176	-.080
7	.395	-.082	26	.238	.180	45	.105	-.163
8	.358	-.186	27	.287	.082	46	.000	-.194
9	.295	-.275	28	.297	-.028	47	-.105	-.163
10	.210	-.345	29	.267	-.133	48	-.176	-.080
11	.109	-.389	30	.201	-.221	49	-.192	.028
12	.000	-.404	31	.108	-.278	50	-.146	.127
13	-.109	-.389	32	.000	-.299	51	-.055	.186
14	-.210	-.345	33	-.108	-.278	52	.000	.088
15	-.295	-.275	34	-.201	-.221	53	.088	.000
16	-.358	-.186	35	-.267	-.133	54	.000	-.088
17	-.395	-.082	36	-.297	-.028	55	-.088	.000
18	-.403	.028	37	-.287	.082			
19	-.380	.135	38	-.238	.180			

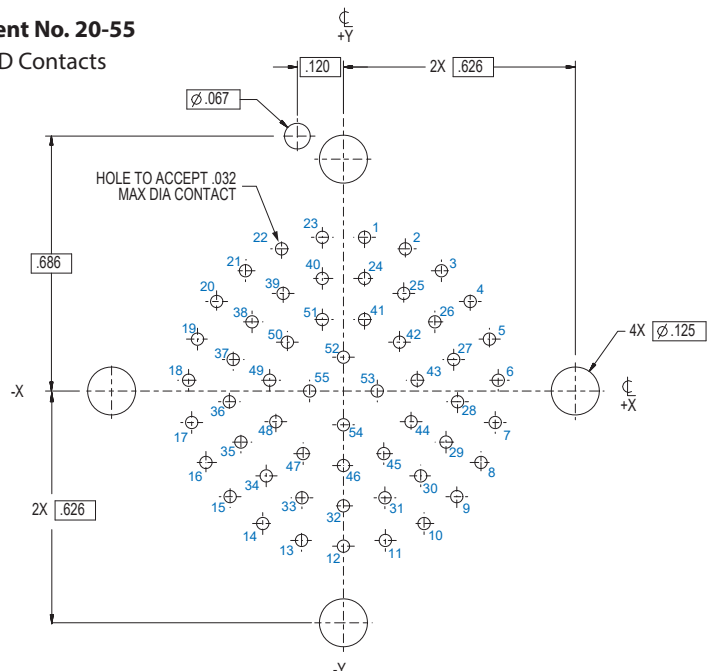



Recommended PCB Layouts are shown for the connector mounting size of PC board. Contact identification numbers are for pin connectors. Socket identification numbers are reversed.

Arrangement No. 20-110 110 #22HD Contacts

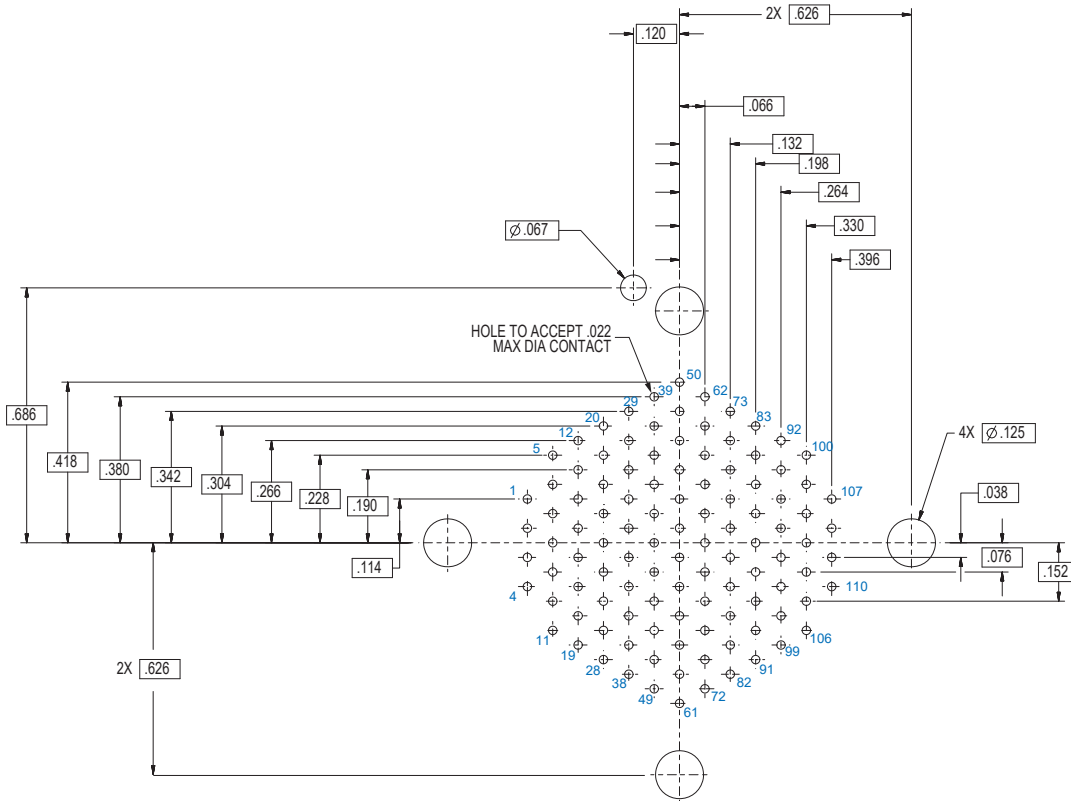



Recommended PCB Layouts are shown for the connector mounting size of PC board. Contact identification numbers are for pin connectors. Socket identification numbers are reversed.

Arrangement No. 22-69

69 #20HD Contacts

Contact Position ID	Location		Contact Position ID	Location	
	X Axis	Y Axis		X Axis	Y Axis
1	.055	.451	36	.055	-.345
2	.161	.425	37	-.055	-.345
3	.258	.374	38	-.158	-.311
4	.340	.301	39	-.247	-.247
5	.402	.211	40	-.311	-.158
6	.441	.109	41	-.345	-.055
7	.454	.000	42	-.345	.055
8	.441	-.109	43	-.311	.158
9	.402	-.211	44	-.247	.247
10	.340	-.301	45	-.158	.311
11	.258	-.374	46	-.055	.345
12	.161	-.425	47	.054	.238
13	.055	-.451	48	.152	.191
14	-.055	-.451	49	.220	.106
15	-.161	-.425	50	.244	.000
16	-.258	-.374	51	.220	-.106
17	-.340	-.301	52	.152	-.191
18	-.402	-.211	53	.054	-.238
19	-.441	-.109	54	-.054	-.238
20	-.454	.000	55	-.152	-.191
21	-.441	.109	56	-.220	-.106
22	-.402	.211	57	-.244	.000
23	-.340	.301	58	-.220	.106
24	-.258	.374	59	-.152	.191
25	-.161	.425	60	-.054	.238
26	-.055	.451	61	.053	.128
27	.055	.345	62	.128	.053
28	.158	.311	63	.128	-.053
29	.247	.247	64	.053	-.128
30	.311	.158	65	-.053	-.128
31	.345	.055	66	-.128	-.053
32	.345	-.055	67	-.128	.053
33	.311	-.158	68	-.053	.128
34	.247	-.247	69	.000	.000
35	.158	-.311			

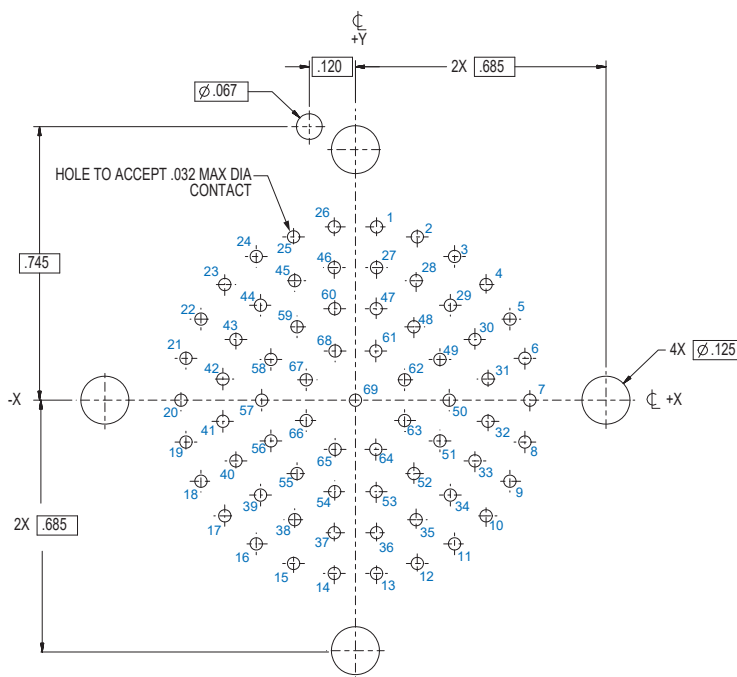



Recommended PCB Layouts are shown for the connector mounting size of PC board. Contact identification numbers are for pin connectors. Socket identification numbers are reversed.

Arrangement No. 22-140
140 #22HD Contacts

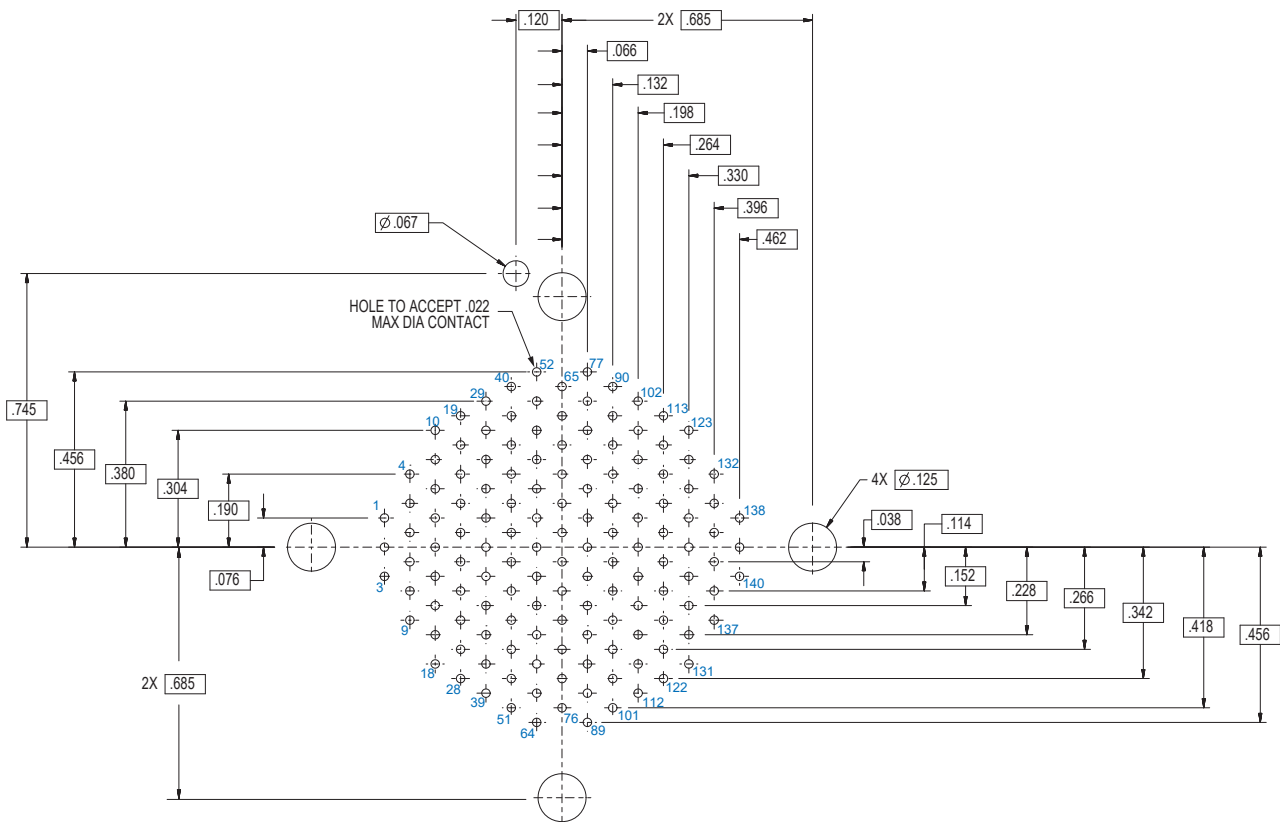



Recommended PCB Layouts are shown for the connector mounting size of PC board. Contact identification numbers are for pin connectors. Socket identification numbers are reversed.

Arrangement No. 24-92

92 #20HD Contacts

Contact Position ID	Location		Contact Position ID	Location	
	X Axis	Y Axis		X Axis	Y Axis
1	.053	.523	47	-.334	-.256
2	.158	.502	48	-.389	-.161
3	.255	.460	49	-.417	-.055
4	.343	.399	50	-.417	.055
5	.416	.322	51	-.389	.161
6	.472	.232	52	-.334	.256
7	.509	.132	53	-.256	.334
8	.525	.027	54	-.161	.389
9	.520	-.080	55	-.055	.417
10	.493	-.183	56	.055	.311
11	.446	-.278	57	.158	.274
12	.381	-.362	58	.242	.203
13	.301	-.432	59	.297	.108
14	.207	-.483	60	.316	.000
15	.106	-.515	61	.297	-.108
16	.000	-.526	62	.242	-.203
17	-.106	-.515	63	.158	-.274
18	-.207	-.483	64	.055	-.311
19	-.301	-.432	65	-.055	-.311
20	-.381	-.362	66	-.158	-.274
21	-.446	-.278	67	-.242	-.203
22	-.493	-.183	68	-.297	-.108
23	-.520	-.080	69	-.316	.000
24	-.525	.027	70	-.297	.108
25	-.509	.132	71	-.242	.203
26	-.472	.232	72	-.158	.274
27	-.416	.322	73	-.055	.311
28	-.343	.399	74	.055	.204
29	-.255	.460	75	.149	.149
30	-.158	.502	76	.204	.055
31	-.053	.523	77	.204	-.055
32	.055	.417	78	.149	-.149
33	.161	.389	79	.055	-.204
34	.256	.334	80	-.055	-.204
35	.334	.256	81	-.149	-.149
36	.389	.161	82	-.204	-.055
37	.417	.055	83	-.204	.055
38	.417	-.055	84	-.149	.149
39	.389	-.161	85	-.055	.204
40	.334	-.256	86	.053	.092
41	.256	-.334	87	.106	.000
42	.161	-.389	88	.053	-.092
43	.055	-.417	89	-.053	-.092
44	-.055	-.417	90	-.106	.000
45	-.161	-.389	91	-.053	.092
46	-.256	-.334	92	.000	.000

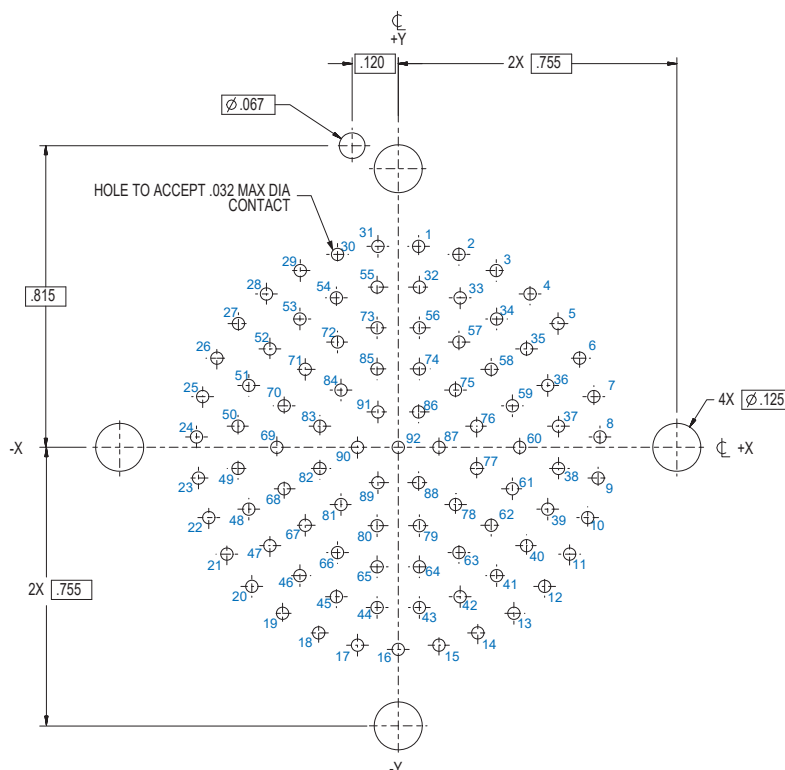

Recommended PCB Layouts are shown for the connector mounting size of PC board. Contact identification numbers are for pin connectors. Socket identification numbers are reversed.

Arrangement No. 24-186
186 #22HD Contacts

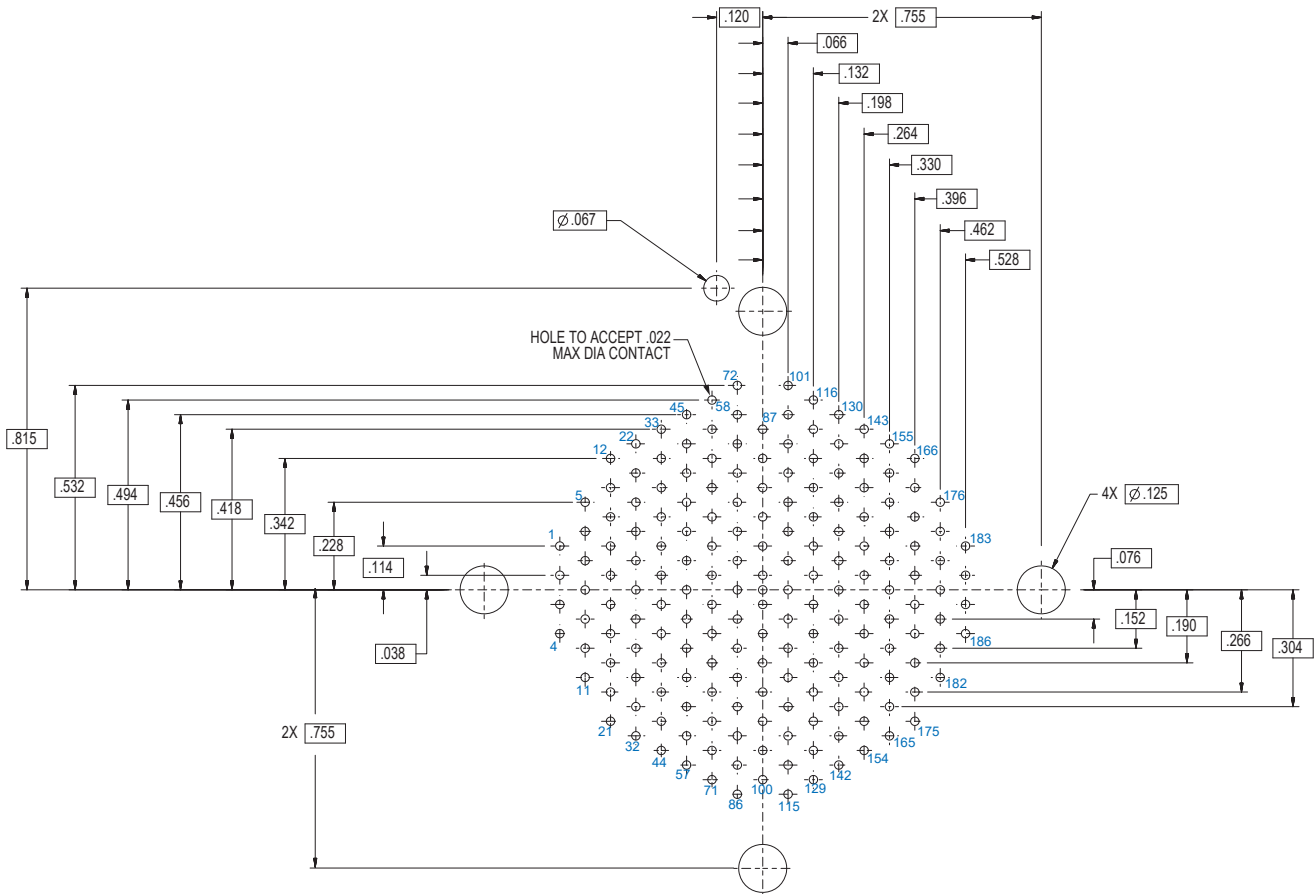



The industry standard for size and weight reduction in mission-critical electrical / optical interconnect systems

SERIES 80
**MIGHTY
MOUSE**

Constant, relentless innovation

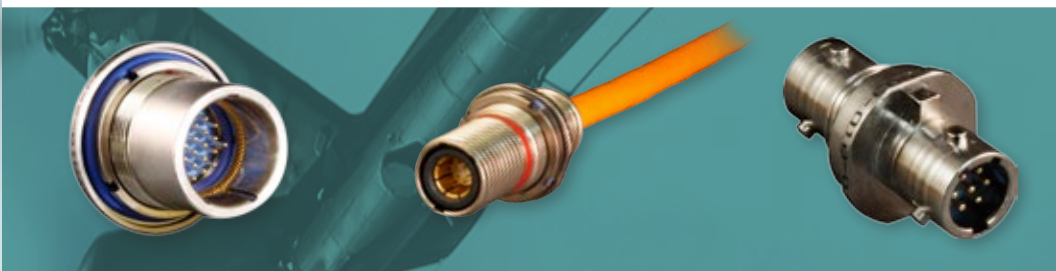
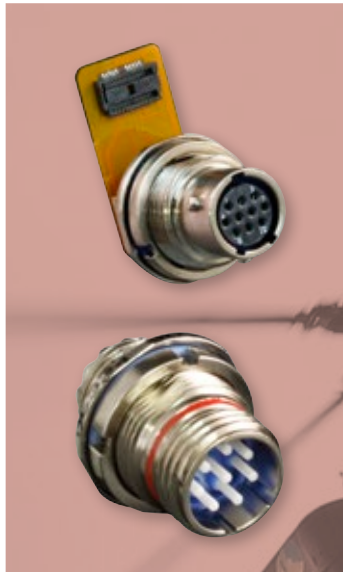



Glencair®



SERIES 80
MIGHTY
MOUSE



Turnkey Point-to-Point Jumpers and Complex Harness Assemblies for Rugged Applications

Massive in-house Mighty Mouse wire harness layout, termination, and test of both COTS and customer-bespoke designs

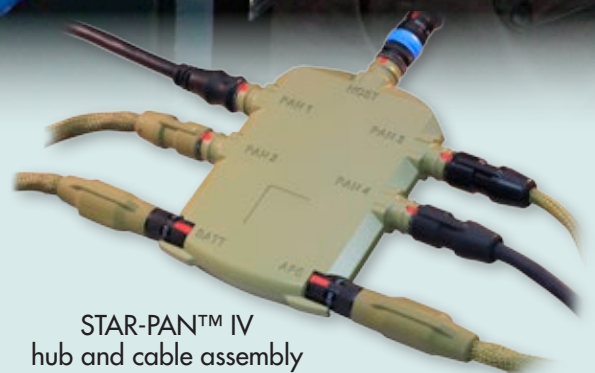

- EMI/RFI shielded cordsets
- STAR-PAN™ series jumpers and cordsets
- Ethernet and other high-speed data application cables
- High-pressure subsea AquaMouse assemblies
- Ultra-flexible overbraided fabric designs
- Ultra harsh-environment overmolded assemblies



Mighty Mouse Complex Cable Assemblies

HARSH ENVIRONMENT OVERMOLDED



Overmolded breakout assembly featuring 100% Glenair content; a true turnkey solution

ULTRAFLEXIBLE FABRIC OVERBRAID



Non-environmental aircraft cable with integrated circuit breakout box and Mighty Mouse 804 push-pull connectors



Multibranch cable assembly with Glenair Mighty Mouse, HiPer-D M24308 and customer-supplied power connector



Heads-up display (HUD) cable with custom Series 804 Mighty Mouse and low-profile cable routing



Turnkey overmolded GPS cable assembly with integrated switch



Military jet jumper cable with user-serviceable backshells and fabric overbraid for mechanical protection



Environmental cable with Glenair Series 804 Mighty Mouse, Series 79 Micro-Crimp, and RF Coax terminations



Hybrid Mighty Mouse and Micro-D aircraft pilot helmet cable assembly



Glencair®



SERIES 80
MIGHTY
MOUSE



**Made in America:
From Design
Engineering to
Component Part
Manufacture and
Assembly**

**Connector shells, plating,
inserts, contacts, environmental
seals, filter arrays, assembly
and test all controlled in-house**



- Largest small form-factor connector engineering team in the industry
- Largest U.S. CNC metal turning operation in the high-rel interconnect industry
- Largest U.S. interconnect component part fabrication and assembly facility
- Massive same-day inventory of Mighty Mouse connectors and cables—bagged, tagged, and ready for immediate shipment

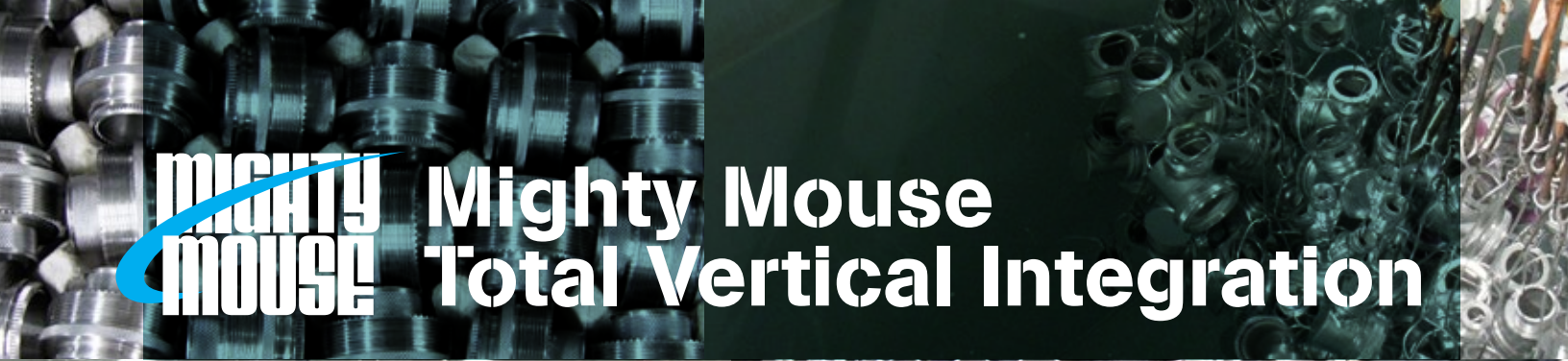

**MIGHTY
MOUSE**

Mighty Mouse Total Vertical Integration





Out of This World
**INTERCONNECT
SOLUTIONS**

Glenair, Inc.

1211 Air Way • Glendale, California • 91201-2497

Telephone: 818-247-6000 • Fax: 818-500-9912 • sales@glenair.com

www.glenair.com

**Glenair Power
Products Group**

860 N. Main Street Extension
Wallingford, CT
06492

Telephone:
203-741-1115
Facsimile:
203-741-0053
sales@glenair.com

Glenair UK Ltd

40 Lower Oakham Way
Oakham Business Park
Mansfield, Notts,
NG18 5BY England

Telephone:
+44-1623-638100
Facsimile:
+44-1623-638111
sales@glenair.co.uk

Glenair Microway Systems

7000 North Lawndale Avenue
Lincolnwood, IL
60712

Telephone:
847-679-8833
Facsimile:
847-679-8849

Glenair Nordic AB

Gustav III : S Boulevard 46
SE-169 27 Solna
Sweden

Telephone:
+46-8-50550000
sales@glenair.se

Glenair Electric GmbH

Schaberweg 28
61348 Bad Homburg
Germany

Telephone:
06172 / 68 16 0
Facsimile:
06172 / 68 16 90
info@glenair.de

Glenair Iberica

C/ La Vega, 16
45612 Velada
Spain

Telephone:
+34-925-89-29-88
Facsimile:
+34-925-89-29-87
sales@glenair.es

Glenair Italia S.p.A.

Via Del Lavoro, 7
40057 Quarto Inferiore –
Granarolo dell'Emilia
Bologna, Italy

Telephone:
+39-051-782811
Facsimile:
+39-051-782259
info@glenair.it

Glenair France SARL

7, Avenue Parmentier
Immeuble Central Parc #2
31200 Toulouse
France

Telephone:
+33-5-34-40-97-40
Facsimile:
+33-5-61-47-86-10
sales@glenair.fr

Glenair Korea

B-1304 Gunpo IT Valley
148 Gosan-Ro, Gunpo-Si
Kyunggi-Do, Korea
435-733

Telephone:
+82-31-8068-1090
Facsimile:
+82-31-8068-1092
sales@glenair.kr

