

MISSION-CRITICAL
INTERCONNECT
SOLUTIONS

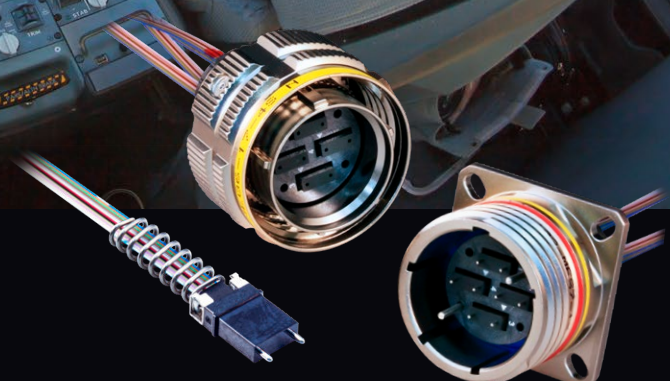

SERIES 183-001

SuperNine[®] MT

Ruggedized, High-Density MT Ferrule Fiber Optics
in Aerospace-Grade MIL-DTL-38999 Connectors

JUNE 2019



SERIES 183-001

SuperNine[®] MT

High-density fiber optic connectors

MT fiber optic ferrules are super-high-density commercial interconnect inserts that accommodate up to 24 fibers in a compact and lightweight package. MT ferrules can be terminated with a wide range of optical media including photonic flex circuitry, ribbon and round cable. MT interconnects are typically used for backplanes or trunk lines—such as in commercial aircraft wiring—where one high density, multi-channel line feeds many branches.

The MT Ferrule High-Density Advantage	
	24 fibers
	3 fibers
<p>Up to 24 fibers in a single compact, lightweight ferrule (7mm x 3mm / .276" x .118")—same real estate as three size #16 termini side by side</p>	

Now, Glenair brings together the high-density of these proven-performance MT ferrules with the durable mating and harsh-environment performance of Glenair SuperNine[®] connectors—the “better than QPL” MIL-DTL-38999 Series III solution with advanced mating and anti-vibration / shock performance. Up to 24 fibers can be packaged in a single size 11 SuperNine[®] Series III Type connector. Four MT ferrules can be combined in one size 17 shell—for up to 96 fibers in a single connector. Glenair SuperNine[®] MT connectors are stocked for complete flexibility in ordering. Simply choose connector configuration and number of desired MT ferrules for either singlemode or multimode use. MT ferrules and tools sold separately.

- Ruggedized “better than QPL” SuperNine[®] MIL-DTL-38999 Series III type interconnect packaging
- Singlemode and multimode fiber
- Low insertion loss
- Environmental sealing: IP67 mated, IP68 available at interface
- RoHS-compliant finishes available
- MT ferrules sold separately
- MT assembly tool, P/N 182-062 also available and sold separately

SERIES 183-001

SuperNine® MT

Super high-density fiber optic connectors

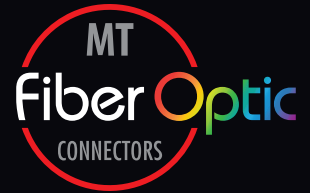

SUPERNINE® MT CONNECTOR SIZES AND INSERT ARRANGEMENTS

SuperNine® MT MIL-DTL-38999 Series III type connectors with plug-and-play MT ferrule accommodation			
Shell Size 11 Insert Arrangement -1 Up to 24 fibers (1 MT ferrule)	Shell Size 13 Insert Arrangement -2 Up to 48 fibers (2 MT ferrules)	Shell Size 15 Insert Arrangement -3 Up to 72 fibers (3 MT ferrules)	Shell Size 17 Insert Arrangement -4 Up to 96 fibers (4 MT ferrules)

Mating face view of available MT ferrule insert arrangements (plug connector shown)			
Shell Size 11 Insert Arrangement -1 Up to 24 fibers (1 MT ferrule)	Shell Size 13 Insert Arrangement -2 Up to 48 fibers (2 MT ferrules)	Shell Size 15 Insert Arrangement -3 Up to 72 fibers (3 MT ferrules)	Shell Size 17 Insert Arrangement -4 Up to 96 fibers (4 MT ferrules)

SuperNine® MT Performance Specifications	
Test Description	Performance Requirements/Specifications
Optical Insertion Loss, Multimode	-0.3 dB Typical (50/125)
Optical Insertion Loss, Singlemode	-0.3 dB Typical (9/125)
Optical Back Reflection, Singlemode	Better than -30 dB - PC Polish
Mechanical Shock (Operational 1)	75G Half Sine, 10 ms Duration, 3 Times Both Direction Each Axis per TIA-455-14A
Mechanical Shock (Operational 2)	300G Half Sine, 3 ms Duration, 3 Times Both Direction Each Axis per TIA-455-14A, Test Condition D
Mechanical Shock (Non-Operational)	36-44G Sawtooth, 10-12 ms Duration, 3 Times Both Directions Each Axis per MIL-STD-810F, Method 516.5
Vibration	Figure 514.5C-8 (36 Grms), 1 hour Exposure Each Axis per MIL-STD-810F, Method 514.5, Procedure 1
Thermal Cycling	5 Cycles, -40°C (At Step 1) to 85°C (At Step 3) with 1 hr. Exposure per EIA-364-32F, Cond. VII, Method A, Test Duration A
Temperature Life	85°C for 336 hours per TIA-455-4C
Humidity	90%-95% RH, 96 hour Exposure per TIA-455-5C, Method A, Test Condition A

TURNKEY SUPERNINE® MT FIBER OPTIC CABLE SETS

Glenair’s experienced fiber optic engineers can design, terminate, and test complex multibranch and point-to-point assemblies incorporating Glenair SuperNine® MT I/O and cable connectors with singlemode and multimode MT ferrules. Panel mount MT receptacles may be terminated to the broad range of standard commercial fiber optic interconnects for turnkey termination to board-level transceivers. Environmental MT plug assemblies are available with ruggedized backshells or in overmolded configurations.



SERIES 183-001 SuperNine MT Fiber Optic Connectors



How to order Cable Plugs

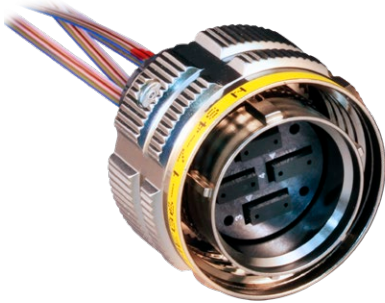

How To Order							
Sample Part Number	183-001	ME	G6	-17	-4	S	N
Basic Part Number	MT Ferrule Fiber Optic Connector						
Material/Finish Code	See Table I						
Connector Style	G6 = Plug with EMI/RFI ground spring						
Shell Size	11, 13, 15, 17						
Insert Arrangement	See Figure 1						
Insert Designator	S = Socket insert (plug only)						
Alternate Key Position	A, B, C, D, E, N = Normal (per MIL-DTL-38999)						

Table I - Material and Finish		
Code	Material	Finish Description
ME	Aluminum Alloy	Electroless Nickel
MT		Nickel-PTFE, Grey
NF		Cadmium, Olive Drab
ZR		Zinc-Nickel, Black
XM	Composite	Electroless Nickel
XW		Cadmium, Olive Drab
Z1	Stainless Steel	Passivate
ZL		Electro-Deposited Nickel

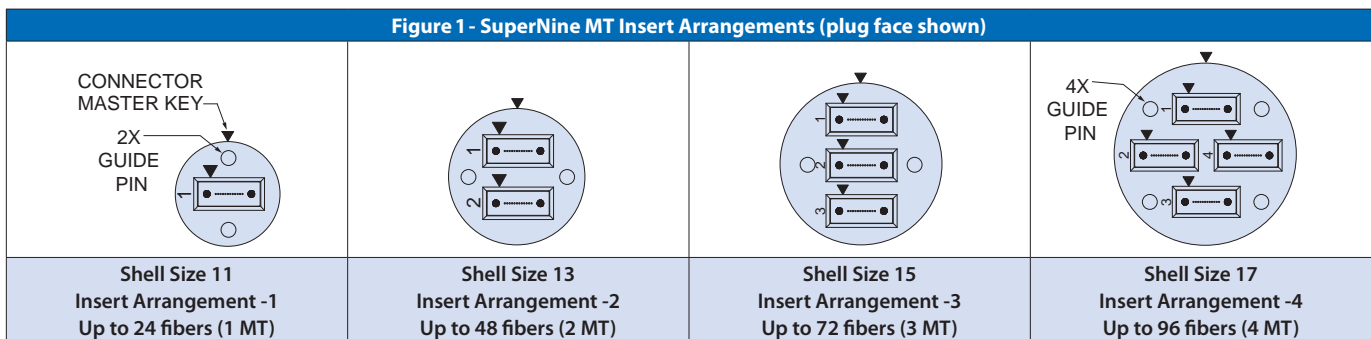

NOTES

Material/Finish

- Coupling nut for composite plug = high-grade rigid dielectric, unplated
- Insulators = high-grade rigid dielectric
- Seals = fluorosilicone
- EMI/RFI ground spring (plug only) = Copper alloy, nickel plated

Connectors are identified with Glenair name, CAGE code, part number and date code

Assembly requires Glenair MT38999 assembly tool, 182-062

SERIES 183-001 SuperNine MT Fiber Optic Connectors

Cable plug dimensions

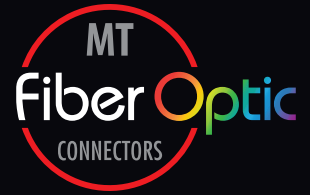

G6 - PLUG

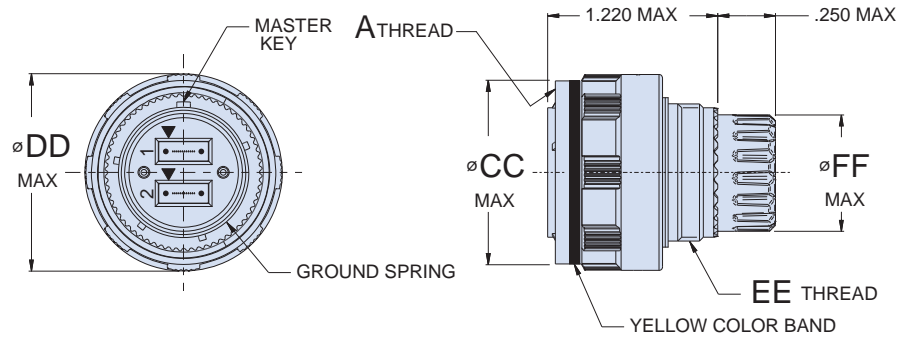
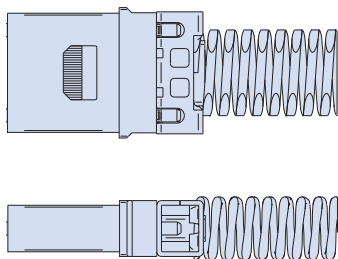

Table II - Plug Dimensions

Shell Size Code	Shell Size	$\varnothing CC$ Max		$\varnothing DD$ Max		EE Thread	$\varnothing FF$ Max	
		In	mm	In	mm		In	mm
B	11	.929	23.60	.984	24.99	M15 X 1.0-6g 0.100R	.392	9.96
C	13	1.110	28.19	1.157	29.39	M18 X 1.0-6g 0.100R	.488	12.40
D	15	1.232	31.29	1.280	32.51	M22 X 1.0-6g 0.100R	.606	15.39
E	17	1.358	34.49	1.406	35.71	M25 X 1.0-6g 0.100R	.724	18.39

MT FERRULE KIT



How To Order MT Ferrules				
Sample Part Number	181-108	-1253	-12	S
Basic Part Number	MT Ferrule kit			
Fiber type	-1253 = Singlemode -126 = Multimode			
Number of Fibers	-12 (12 fibers, available in singlemode and multimode) -24 (24 fibers, available in multimode only)			
Ferrule Style	S = Female (Plug Only)			

Material/Finish

- Ferrule: Polyphenylene Sulfide Resin
- Spacer, Female: High-grade engineering plastic
- Spring: Stainless Steel
- Boot: TPE



How To Order							
Sample Part Number	183-001	ME	08	-17	-4	P	N
Basic Part Number	MT Ferrule Fiber Optic Connector						
Material/Finish Code	See Table I						
Connector Style	08 = Jam nut receptacle						
Shell Size	11, 13, 15, 17						
Insert Arrangement	See Figure 1						
Insert Designator	P = Pin insert (receptacle only)						
Alternate Key Position	A, B, C, D, E, N = Normal (per MIL-DTL-38999)						

Table I - Material and Finish		
Code	Material	Finish Description
ME	Aluminum Alloy	Electroless Nickel
MT		Nickel-PTFE, Grey
NF		Cadmium, Olive Drab
ZR		Zinc-Nickel, Black
XM	Composite	Electroless Nickel
XW		Cadmium, Olive Drab
Z1	Stainless Steel	Passivate
ZL		Electro-Deposited Nickel

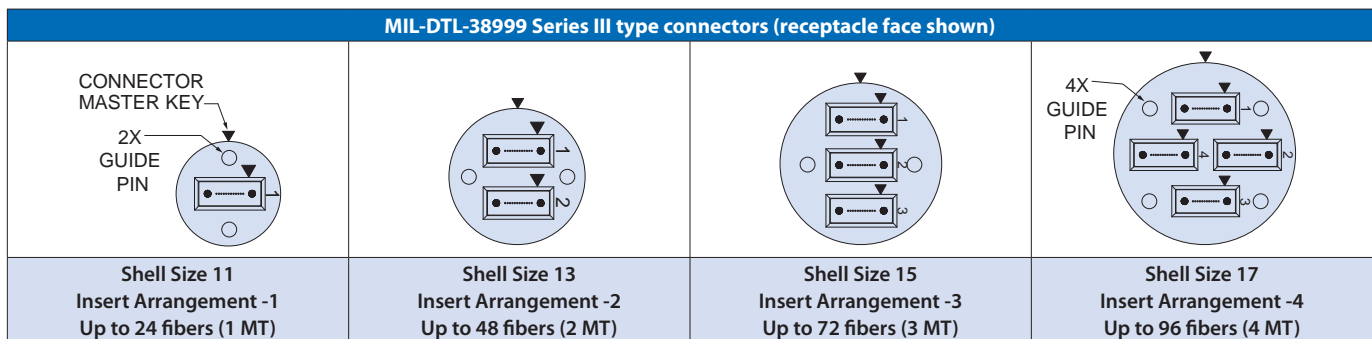

NOTES

Material/Finish

- Jam nut for composite receptacles = Al alloy, plated per table I
- Insulators = high-grade rigid dielectric
- Seals = fluorosilicone

Connectors are identified with Glenair name, CAGE code, part number and date code

Assembly requires Glenair MT38999 assembly tool, 182-062

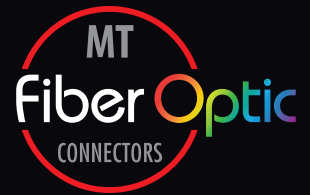

08 - JAM NUT MOUNT RECEPTACLE

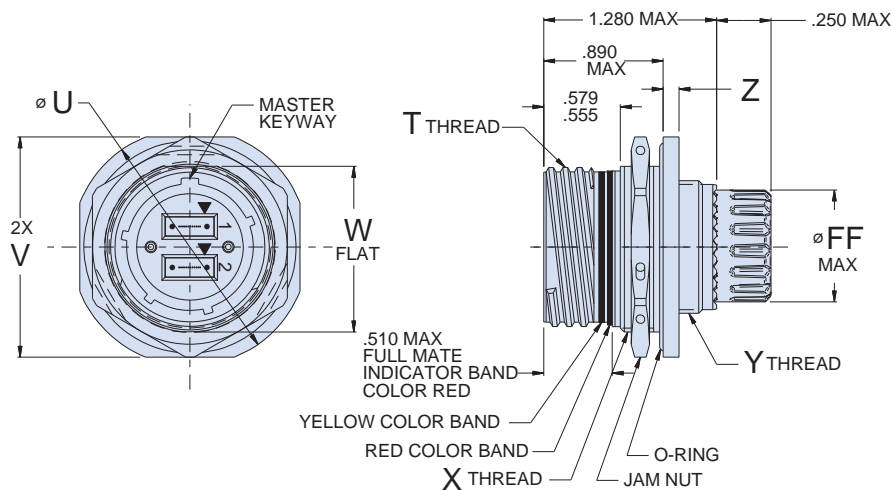

Table IV - Panel Cutout

Shell Size Code	Shell Size	ØAA		ØBB Flat	
		In	mm	In	mm
B	11	.835	21.21	.771	19.58
		.825	20.96	.761	19.33
C	13	1.020	25.91	.955	24.26
		1.010	25.65	.945	24.00
D	15	1.145	29.08	1.085	27.56
		1.135	28.83	1.075	27.31
E	17	1.270	32.26	1.210	30.73
		1.260	32.00	1.200	30.48

Table III - Jam Nut Receptacle Dimensions

Shell Size Code	Shell Size	T Thread	ØU		V		W Flat		X Thread	Y Thread	Z		ØFF Max	
			In	mm	In	mm	In	mm			In	mm	In	mm
B	11	.7500-.1P-.3L-TS-2A	1.386	35.20	1.268	32.21	0.755	19.18	M20 X 1.0-6g 0.100R	M15 X 1.0-6g 0.100R	.122	3.10	.392	9.96
			1.362	34.59	1.236	31.39	0.745	18.92					.488	12.40
C	13	.8750-.1P-.3L-TS-2A	1.512	38.40	1.390	35.31	0.942	23.93	M25 X 1.0-6g 0.100R	M18 X 1.0-6g 0.100R	.083	2.11	.606	15.39
			1.488	37.80	1.358	34.49	0.932	23.67					.724	18.39
D	15	1.0000-.1P-.3L-TS-2A	1.638	41.61	1.516	38.51	1.066	27.08	M28 X 1.0-6g 0.100R	M22 X 1.0-6g 0.100R				
			1.614	41.00	1.484	37.69	1.056	26.82						
E	17	1.1875-.1P-.3L-TS-2A	1.764	44.81	1.642	41.71	1.191	30.25	M32 X 1.0-6g 0.100R*	M25 X 1.0-6g 0.100R				
			1.740	44.20	1.610	40.89	1.181	30.00						

*Modified major diameter 31.80 – 31.95 (1.252 – 1.257mm)

MT FERRULE KIT

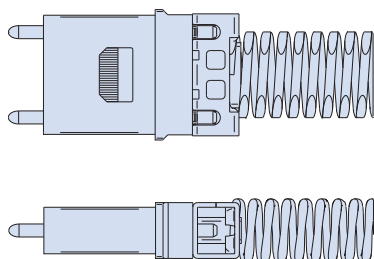

How To Order MT Ferrules

Sample Part Number	181-108	-1253	-12	P
Basic Part Number	MT Ferrule kit			
Fiber type	-1253 = Singlemode -126 = Multimode			
Number of Fibers	-12 (12 fibers, available in singlemode and multimode) -24 (24 fibers, available in multimode only)			
Ferrule Style	P = Male (Recp Only)			

Material/Finish

- Ferrule: Polyphenylene Sulfide Resin
- Guide Pin: Stainless Steel
- Spring: Stainless Steel
- Boot: TPE

SERIES 183-001 SuperNine MT Fiber Optic Connectors



How to order in-line receptacles



How To Order							
Sample Part Number	183-001	ME	05	-17	-4	P	N
Basic Part Number	MT Ferrule Fiber Optic Connector						
Material/Finish Code	See Table I						
Connector Style	05 = In-line receptacle						
Shell Size	11, 13, 15, 17						
Insert Arrangement	See Figure 1						
Insert Designator	P = Pin insert (receptacle only)						
Alternate Key Position	A, B, C, D, E, N = Normal (per MIL-DTL-38999)						

Table I - Material and Finish		
Code	Material	Finish Description
ME	Aluminum Alloy	Electroless Nickel
MT		Nickel-PTFE, Grey
NF		Cadmium, Olive Drab
ZR		Zinc-Nickel, Black
XM	Composite	Electroless Nickel
XW		Cadmium, Olive Drab
Z1	Stainless Steel	Passivate
ZL		Electro-Deposited Nickel

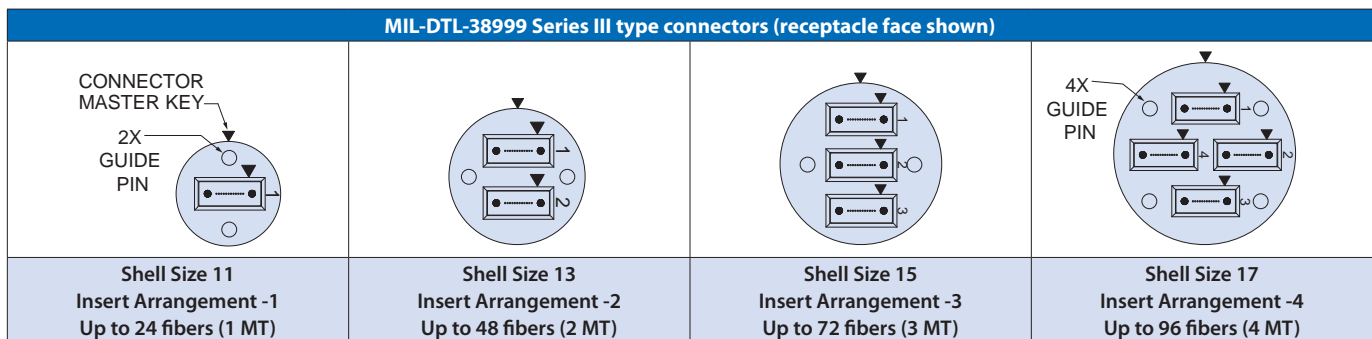

NOTES

Material/Finish

- Insulators = high-grade rigid dielectric
- Seals = fluorosilicone

Connectors are identified with Glenair name, CAGE code, part number and date code

Assembly requires Glenair MT38999 assembly tool, 182-062

SERIES 183-001 SuperNine MT Fiber Optic Connectors

In-line receptacle dimensions

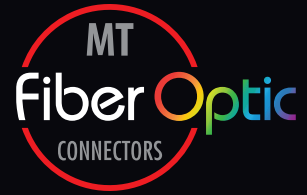

05 - IN-LINE RECEPTACLE

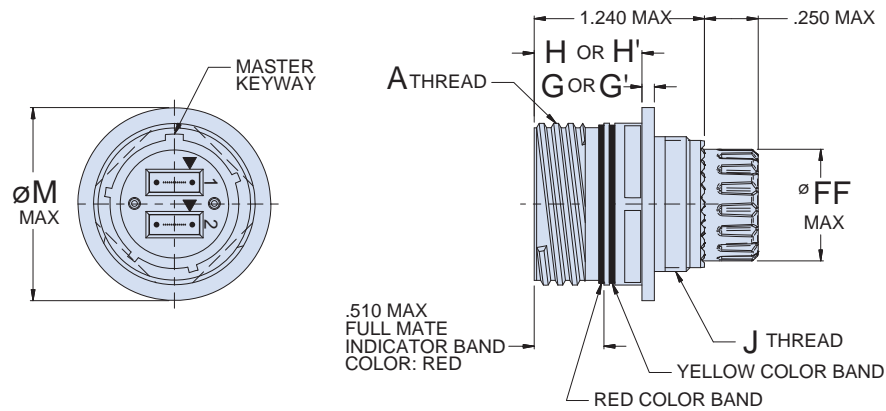

Composite connectors use dimensions G' and H'

Table V - In-Line Receptacle Dimensions

Shell Size Code	Shell Size	A Thread	G		G'		H		H'		J Thread	ØM Max		ØFF Max	
			In	mm	In	mm	In	mm	In	mm		In	mm	In	mm
B	11	.7500-.1P-.3L-TS-2A									M15 X 1.0-6g 0.100R	.984	24.99	.392	9.96
C	13	.8750-.1P-.3L-TS-2A	.098	2.49	.144	3.66	.820	20.83	.823	20.90	M18 X 1.0-6g 0.100R	1.157	29.39	.488	12.40
D	15	1.0000-.1P-.3L-TS-2A	.083	2.11	.083	2.11	.771	19.58	.768	19.51	M22 X 1.0-6g 0.100R	1.280	32.51	.606	15.39
E	17	1.1875-.1P-.3L-TS-2A									M25 X 1.0-6g 0.100R	1.406	35.71	.724	18.39

MT FERRULE KIT

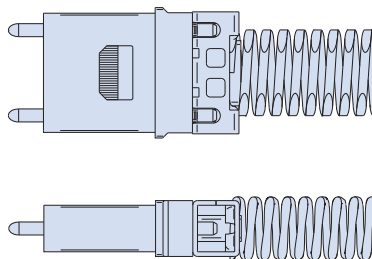

How To Order MT Ferrules				
Sample Part Number	181-108	-1253	-12	P
Basic Part Number	MT Ferrule kit			
Fiber type	-1253 = Singlemode -126 = Multimode			
Number of Fibers	-12 (12 fibers, available in singlemode and multimode) -24 (24 fibers, available in multimode only)			
Ferrule Style	P = Male (Recep Only)			

Material/Finish

- Ferrule: Polyphenylene Sulfide Resin
- Guide Pin: Stainless Steel
- Spring: Stainless Steel
- Boot: TPE

SuperNine MT Fiber Optic Connectors



How to order wall-mount receptacles with standard round holes



How To Order							
Sample Part Number	183-001	ME	H7	-17	-4	P	N
Basic Part Number	MT Ferrule Fiber Optic Connector						
Material/Finish Code	See Table I						
Connector Style	H7 = Wall-mount receptacle with standard round holes						
Shell Size	11, 13, 15, 17						
Insert Arrangement	See Figure 1						
Insert Designator	P = Pin insert (receptacle only)						
Alternate Key Position	A, B, C, D, E, N = Normal (per MIL-DTL-38999)						

Table I - Material and Finish		
Code	Material	Finish Description
ME	Aluminum Alloy	Electroless Nickel
MT		Nickel-PTFE, Grey
NF		Cadmium, Olive Drab
ZR		Zinc-Nickel, Black
XM	Composite	Electroless Nickel
XW		Cadmium, Olive Drab
Z1	Stainless Steel	Passivate
ZL		Electro-Deposited Nickel

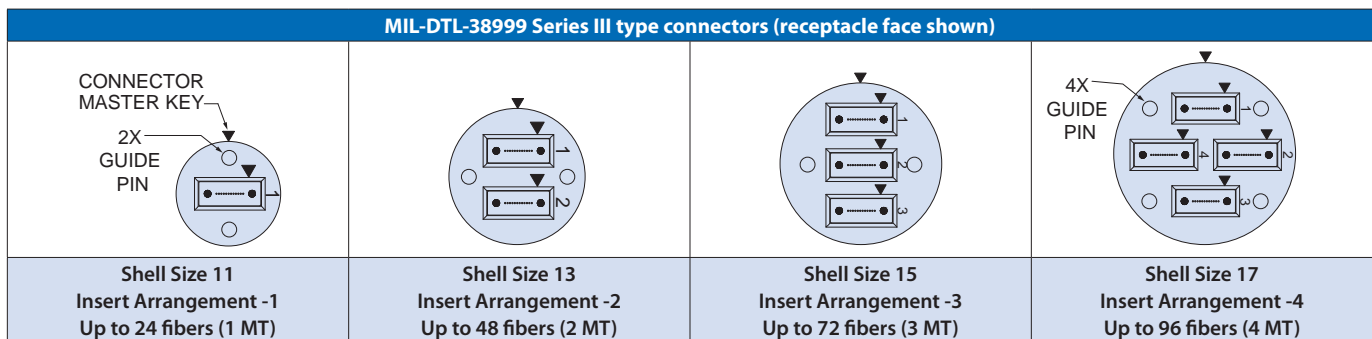

NOTES

Material/Finish

- Insulators = high-grade rigid dielectric
- Seals = fluorosilicone

Connectors are identified with Glenair name, CAGE code, part number and date code

Assembly requires Glenair MT38999 assembly tool, 182-062

SuperNine MT Fiber Optic Connectors

Wall mount receptacle with standard round holes dimensions

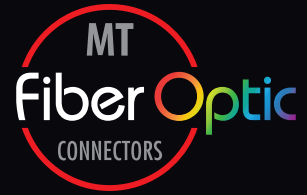

H7 - WALL MOUNT RECEPTACLE WITH STANDARD HOLES (FRONT OR REAR PANEL MOUNT)

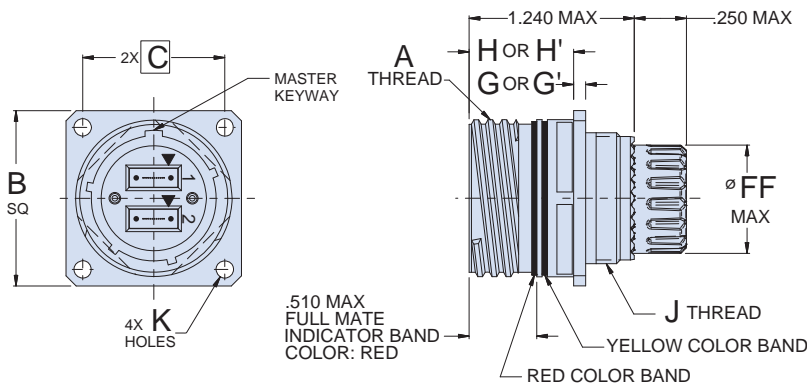

Table VI - Front or Rear Mounting Holes

Diagram showing rear and front panel mounting hole patterns. The rear panel mount shows four holes with diameter ϕR and spacing S . The front panel mount shows four holes with diameter ϕP and spacing S . Dimensions ϕN MIN and ϕP MIN are also indicated.

Shell Size Code	Shell Size	ϕN Min.	ϕP Min.	ϕR Holes	S Bsc				
		In	mm	In	mm				
B	11	.796	20.22	.625	15.88	.133	3.38	.812	20.62
C	13	.922	23.42	.750	19.05	.133	3.38	.906	23.01
D	15	1.047	26.59	.906	23.01	.123	3.12	.969	24.61
E	17	1.219	30.96	1.016	25.81			1.062	26.97

Table V - Wall Mount Receptacle Dimensions

Shell Size Code	Shell Size	A Thread	B Sq		C Bsc		G		G'		H		H'		J Thread	ϕK Holes		ϕFF Max	
			In	mm	In	mm	In	mm	In	mm	In	mm	In	mm		In	mm	In	mm
B	11	.7500-.1P-.3L-TS-2A	1.043	26.49	.812	20.62									M15 X 1.0-6g 0.100R				
			1.019	25.88															
C	13	.8750-.1P-.3L-TS-2A	1.138	28.91	.906	23.01	.098	2.49	.144	3.66	.820	20.83	.823	20.90	M18 X 1.0-6g 0.100R				
			1.114	28.30															
D	15	1.0000-.1P-.3L-TS-2A	1.232	31.29	.969	24.61	.083	2.11	.083	2.11	.771	19.58	.768	19.51	M22 X 1.0-6g 0.100R				
			1.208	30.68															
E	17	1.1875-.1P-.3L-TS-2A	1.323	33.60	1.062	26.97									M25 X 1.0-6g 0.100R				
			1.299	32.99															

MT FERRULE KIT

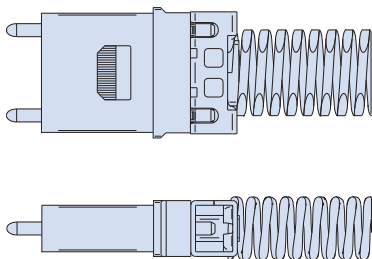

How To Order MT Ferrules

Sample Part Number	181-108	-1253	-12	P
Basic Part Number	MT Ferrule kit			
Fiber type	-1253 = Singlemode -126 = Multimode			
Number of Fibers	-12 (12 fibers, available in singlemode and multimode) -24 (24 fibers, available in multimode only)			
Ferrule Style	P = Male (Recp Only)			

Material/Finish

- Ferrule: Polyphenylene Sulfide Resin
- Guide Pin: Stainless Steel
- Spring: Stainless Steel
- Boot: TPE

SuperNine MT Fiber Optic Connectors



How to order wall-mount receptacles with slotted holes

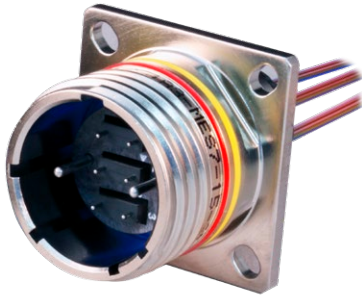

How To Order	
Sample Part Number	183-001 ME S7 -17 -4 P N
Basic Part Number	MT Ferrule Fiber Optic Connector
Material/Finish Code	See Table I
Connector Style	S7 = Wall-mount receptacle with slotted holes
Shell Size	11, 13, 15, 17
Insert Arrangement	See Figure 1
Insert Designator	P = Pin insert (receptacle only)
Alternate Key Position	A, B, C, D, E, N = Normal (per MIL-DTL-38999)

Table I - Material and Finish		
Code	Material	Finish Description
ME	Aluminum Alloy	Electroless Nickel
MT		Nickel-PTFE, Grey
NF		Cadmium, Olive Drab
ZR		Zinc-Nickel, Black
XM	Composite	Electroless Nickel
XW		Cadmium, Olive Drab
Z1	Stainless Steel	Passivate
ZL		Electro-Deposited Nickel

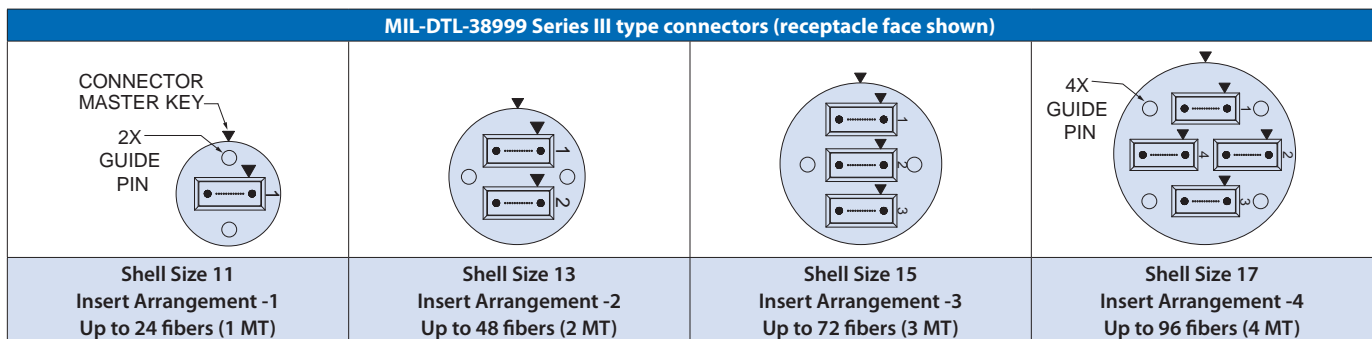

NOTES

Material/Finish

- Insulators = high-grade rigid dielectric
- Seals = fluorosilicone

Connectors are identified with Glenair name, CAGE code, part number and date code

Assembly requires Glenair MT38999 assembly tool, 182-062

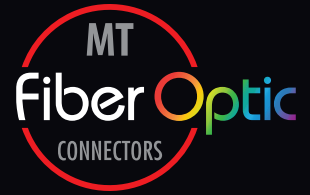

H7 - WALL MOUNT RECEPTACLE WITH SLOTTED HOLES (FRONT PANEL MOUNT ONLY)

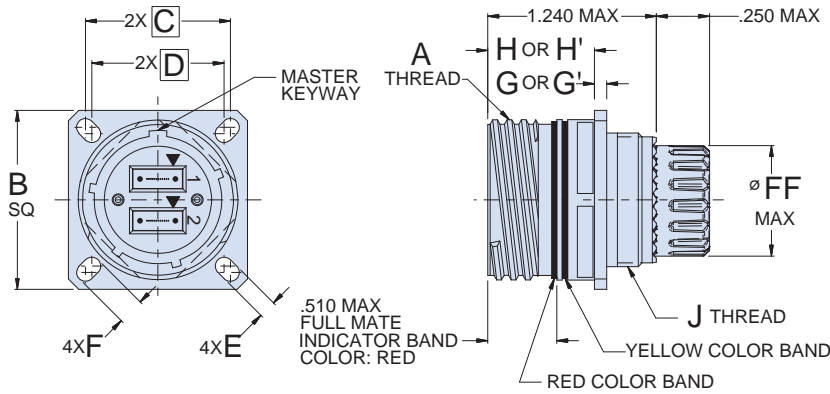
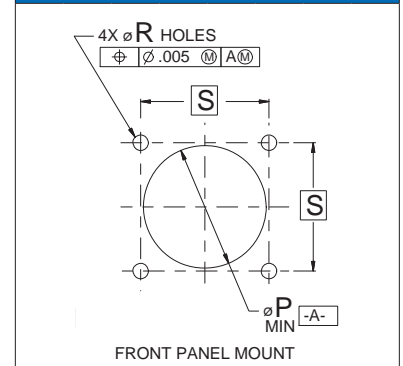

Table VI - Front Panel Mounting Holes



Shell Size Code	Shell Size	A Thread	B Sq		C Bsc		D Bsc		E		F	
			In	mm	In	mm	In	mm	In	mm	In	mm
B	11	.7500-.1P-.3L-TS-2A	1.043 1.019	26.49 25.88	.812	20.62	.719	18.26	.136 .120	3.45 3.05	0.202	5.13
C	13	.8750-.1P-.3L-TS-2A	1.138 1.114	28.91 28.30	.906	23.01	.812	20.62			0.186	4.72
D	15	1.0000-.1P-.3L-TS-2A	1.232 1.208	31.29 30.68	.969	24.61	.906	23.01			0.181	4.60
E	17	1.1875-.1P-.3L-TS-2A	1.323	33.60	1.062	26.97	.969	24.61			0.202	5.13
			1.299	32.99							0.186	4.72

Shell Size Code	Shell Size	ØP Min.		ØR Holes		S Bsc	
		In	mm	In	mm	In	mm
B	11	.625	15.88	.133 .123	3.38 3.12	.812	20.62
C	13	.750	19.05			.906	23.01
D	15	.906	23.01			.969	24.61
E	17	1.016	25.81			1.062	26.97

Shell Size Code	Shell Size	G		G'		H		H'		J Thread		ØFF Max	
		In	mm	In	mm	In	mm	In	mm	In	mm	In	mm
B	11	.098	2.49	.144	3.66	.820	20.83	.823	20.90	M15 X 1.0-6g 0.100R	.392	9.96	
C	13									M18 X 1.0-6g 0.100R	.488	12.40	
D	15									M22 X 1.0-6g 0.100R	.606	15.39	
E	17									M25 X 1.0-6g 0.100R	.724	18.39	

MT FERRULE KIT

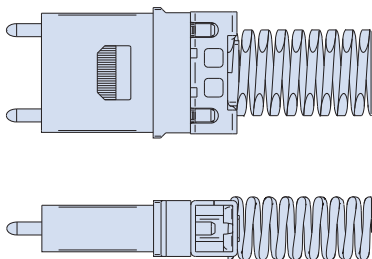

How To Order MT Ferrules				
Sample Part Number	181-108	-1253	-12	P
Basic Part Number	MT Ferrule kit			
Fiber type	-1253 = Singlemode -126 = Multimode			
Number of Fibers	-12 (12 fibers, available in singlemode and multimode) -24 (24 fibers, available in multimode only)			
Ferrule Style	P = Male (Recp Only)			

Material/Finish

- Ferrule: Polyphenylene Sulfide Resin
- Guide Pin: Stainless Steel
- Spring: Stainless Steel
- Boot: TPE

SuperNine MT Fiber Optic Connectors



189-136 EMI/environmental backshell with banding porch and strain relief



How To Order										
Sample Part Number	189	H	S	136	M	17	11	-3	D	K
Basic Part Number	EMI/environmental backshell									
Connector Designator	H = MIL-DTL-38999, Ser. III									
Angular Function	S = Straight M = 45° N = 90°									
Basic No.	136									
Material/Finish Code	See Table II									
Shell Size	See Table I									
Dash No.	See Table III									
Length in 1/2 inch increments	Example: 3 = 1.5 inches									
Fitting Option	D = Dome Fitting F = Flex Fitting									
Band Option	B = Band (Uncoiled) K = Band (Pre-coiled) Omit for none									

Shell Size	A Thread Isometric	B Max	C Max	D Max	E Max	F Max	G ±.015	Max Entry Size Table III
11	M15 x 1 - 6H	1.00	.861	1.111	1.563	1.875	.437	08
13	M18 x 1 - 6H	1.13	.911	1.161	1.938	2.250	.562	10
15	M22 x 1 - 6H	1.22	.965	1.215	1.938	2.250	.678	10
17	M25 x 1 - 6H	1.35	1.014	1.264	2.063	2.375	.812	10

Code	Material	Finish Description
ME	AL Alloy	Electroless Nickel
MT		Nickel-PTFE, Grey
NF		Cadmium, Olive Drab
ZR		Zinc-Nickel, Black
Z1	Stainless	Passivate
ZL	Steel	Electro-Deposited Nickel

Dash No.	Cable Sealing Range	T DIA ±.005	V DIA Max	W Hex	X Dim	Y Dim	Z Max	C2 Max	D2 Max	E2 Max	F2 Max	G2 ±.015	MIL-I-23053 Shrink Sleeve	MIL-I-23053 Shrink Sleeve
06	.16/.31	.31	.93	.75	2.5	.87	N/A	N/A	N/A	N/A	N/A	N/A	/4-204-0	/4-203-0
07	.20/.38	.38	.99	.87	3.1	.98	N/A	N/A	N/A	N/A	N/A	N/A	/4-204-0	/4-203-0
08	.24/.44	.44	1.05	.94	3.6	1.06	N/A	N/A	N/A	N/A	N/A	N/A	/4-204-0	/4-203-0
09	.39/.50	.50	1.12	1.06	4.0	1.10	1.13	.911	1.161	1.938	2.250	.562	/4-205-0	/4-204-0
10	.39/.56	.56	1.18	1.06	4.0	1.10	1.22	.911	1.161	1.938	2.250	.678	/4-205-0	/4-204-0

NOTES

Glenair 600 series backshell assembly tools are recommended for assembly and installation. When maximum cable range Table III exceeds ØG, Style II will be supplied. Standard minimum length: 1.5 inches; for a shorter length, consult the factory. Material/Finish:

- Adapter, coupling nut: See Table II
- Strain relief components: Nylon 6/6 (flame resistant/zero halogen)
- Anti-rotation device: High-grade engineering plastic
- O-rings: Fluorosilicone/N.A.

SERIES 183-001

SuperNine MT Fiber Optic Connectors

189-136 EMI/environmental backshell with banding porch and strain relief

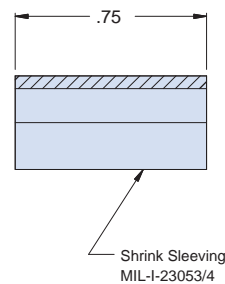
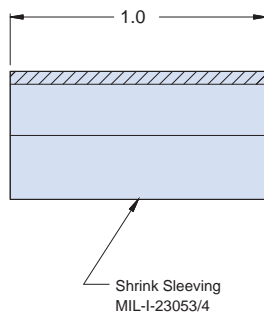
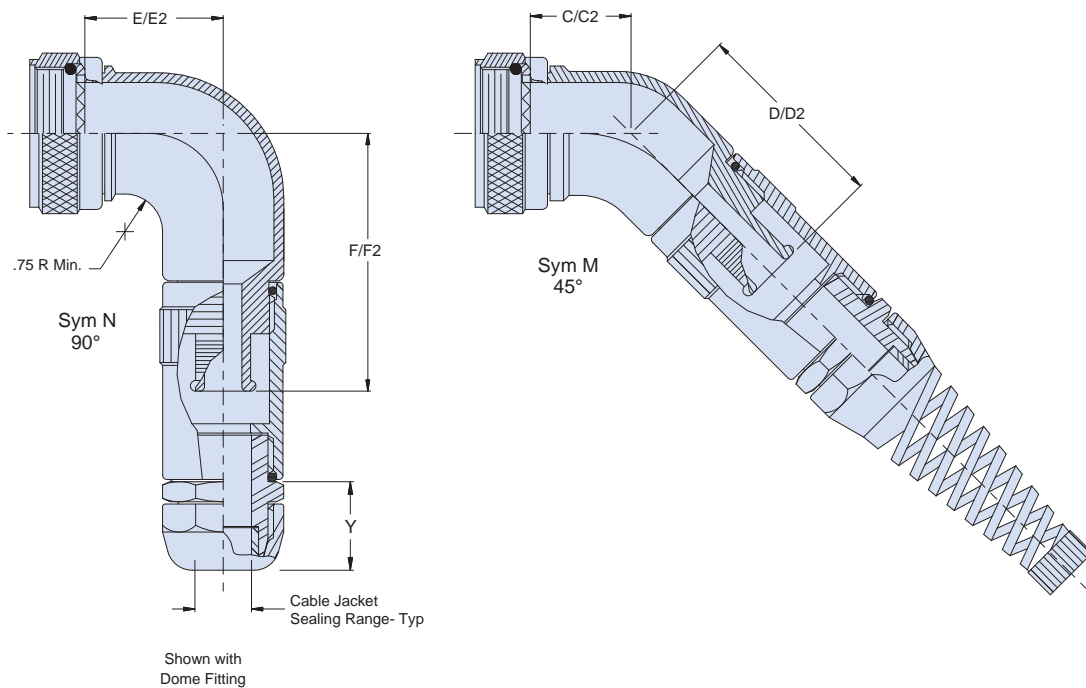
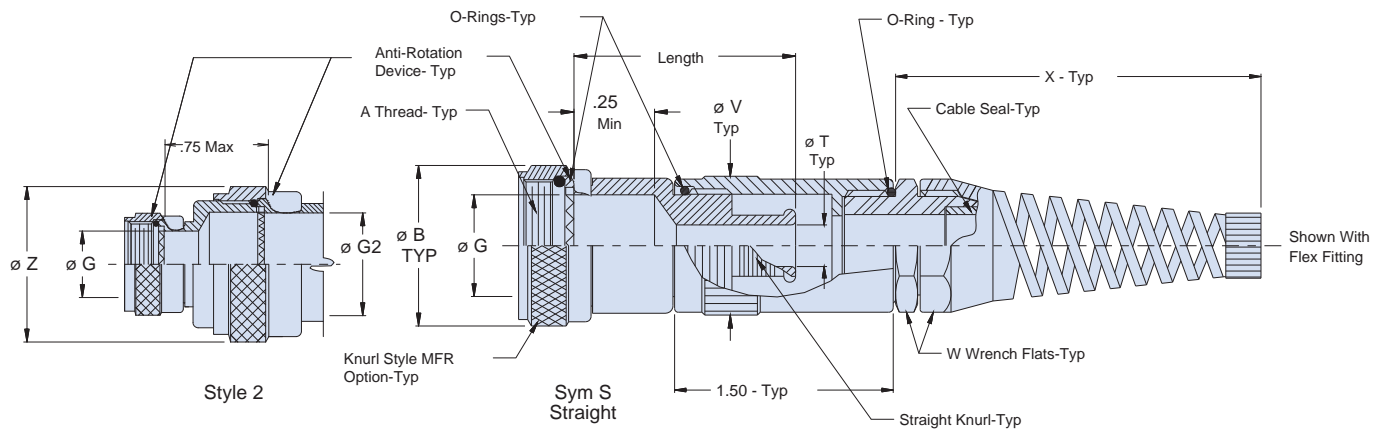
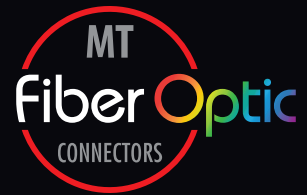

SERIES 183-001
SuperNine MT Fiber Optic Connectors
189-133 Conduit adapter



How To Order										
Sample Part Number	189	H	S	133	ME	11	06	K	D	-3
Basic Part Number	Conduit adapter									
Connector Designator	H = MIL-DTL-38999, Ser. III & IV									
Angular Function	S = Straight M = 45° N = 90°									
Basic Number	133									
Material/Finish Code	See Table II									
Shell Size	See Table I									
Tubing Size	See Table III									
Conduit material designator	K = PEEK Omit for OFA, ETFE, OR FEP									
Overbraid	D = Black dacron Omit for none									
Length	in 1/2 inch increments. Example: 3 = 1.5 inches (Applicable for Straight backshell only. Standard min. length = 1.5 in., contact factory for shorter lengths.)									

Table I								
Shell Size	A Thread Isometric	B Max DIA	C Max DIA	D Max DIA	F Max DIA	G Max DIA	H Max DIA	Max Entry Max Tubing Size
11	M15 x 1 - 6H	.820	.940	.645	1.020	.935	1.310	12
13	M18 x 1 - 6H	.940	1.060	.695	1.070	1.055	1.430	16
15	M22 x 1 - 6H	1.070	1.190	.745	1.120	1.185	1.560	20
17	M25 x 1 - 6H	1.210	1.380	.800	1.175	1.315	1.690	24

Table II		
Sym	Material	Finish Description
ME	Aluminum Alloy	Electroless Nickel
MT		Nickel- Pife, Gray
NF		Cad/O. O. Over Electroless Nickel
ZN		Zinc Nickel/O. O. Over Electroless Nickel
ZNU		Zinc Nickel/Black Over Electroless Nickel
Z1	Stainless Steel	Passivate
ZL		Electrodeposited Nickel

Table III		
Dash Number	Conduit I. D. Min	C DIA Ref
06	.181	.188
09	.273	.281
10	.300	.312
12	.359	.397
14	.427	.438
16	.480	.511
20	.603	.636
24	.725	.761

SERIES 183-001
SuperNine MT Fiber Optic Connectors
189-133 Conduit adapter

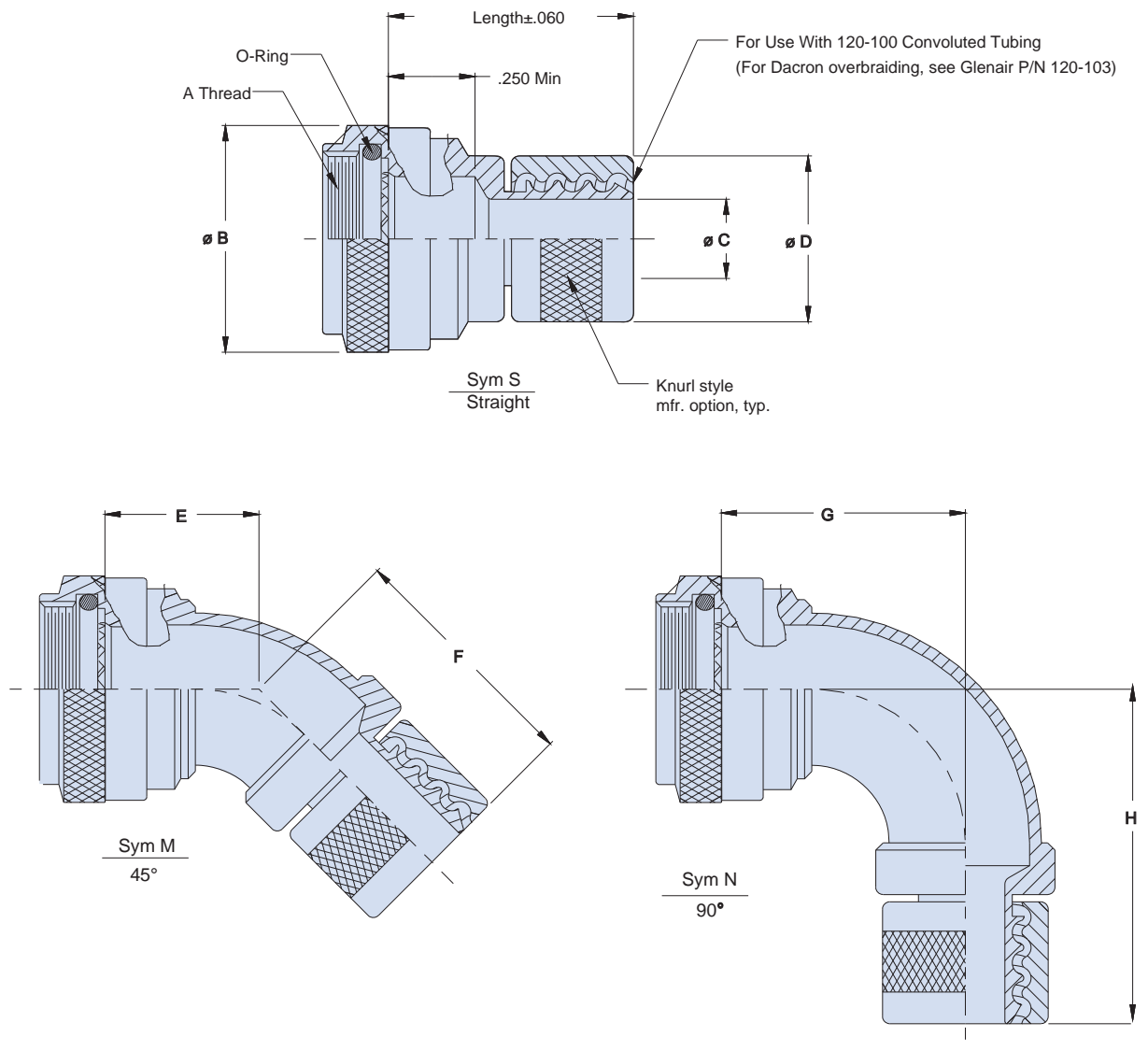
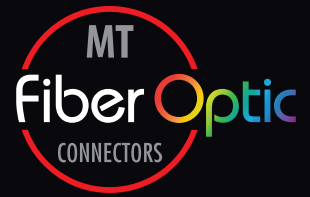

NOTES

- Glenair 600 series backshell assembly tools are recommended for assembly and installation.
- Material/Finish:
- Adapter, coupling nut, and compression nut: See Table II
 - O-rings: Fluorosilicone

SuperNine MT Fiber Optic Connectors



Metal and composite protective covers
660-023 and -024 • 660-049 and -050



How To Order							
Sample Part Number	660	-024	ME	17	H	5	-06
Basic Part Number	Product series - protective covers						
Cover Type	-023 = Metal plug cover -024 = Metal receptacle cover		-049 = Composite plug cover -050 = Composite receptacle cover				
Material/Finish	See Table II						
Shell Size	11, 13, 15, 17						
Lanyard	See Table III						
Attachment Length	In inches						
Attachment Dash No.	Table IV, V, VI or VII • Omit for "SK" slip knot attachment						

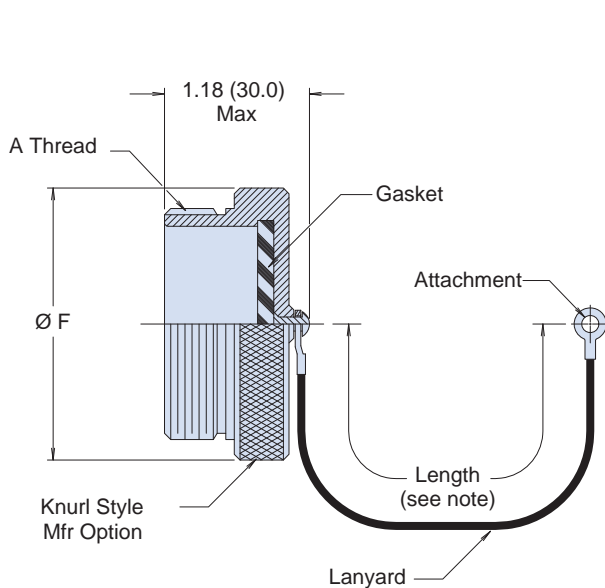

-023 and -049
Plug Covers

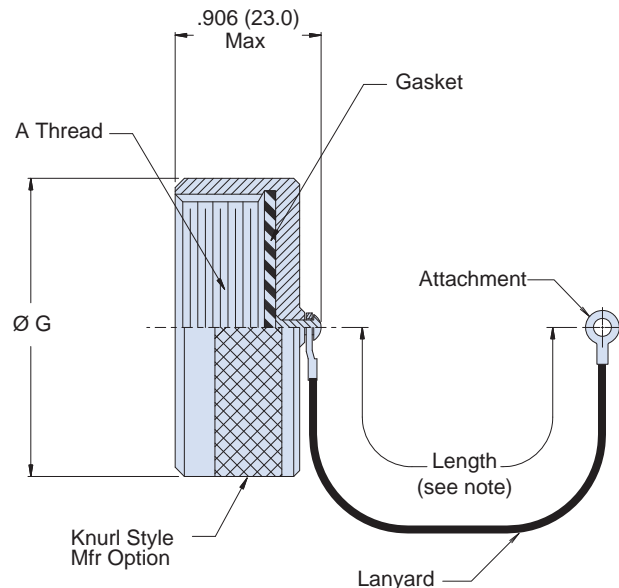

-024 and -050
Receptacle Covers

NOTES

Material and Finish

- Cover: See Table II
- Gasket: Silicone
- Hardware, Rivet: Stainless Steel/Passivate

Length tolerance for Sash Chain (S) is ± 1 link, for all other attachments $\pm .25$.

SERIES 183-001

SuperNine MT Fiber Optic Connectors

Metal and composite protective covers
660-023 and -024 • 660-049 and -050

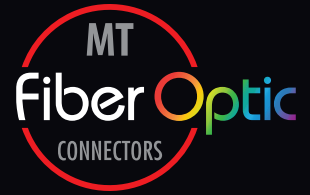

Available Lanyard Types (shown with optional eyelet attachment, see table III for lanyard style)



		
Bead Chain (Type D)	Sash Chain (Type S)	Rope (Type H)

Table I - Dimensions

Shell Size	A Thread	Ø F Max	Ø G Max
11	.7500 - 0.1P-0.3L-TS	1.024 (26.0)	1.102 (28.0)
13	.8750 - 0.1P-0.3L-TS	1.220 (31.0)	1.220 (31.0)
15	1.0000 - 0.1P-0.3L-TS	1.300 (33.0)	1.260 (32.0)
17	1.1875 - 0.1P-0.3L-TS	1.457 (37.0)	1.457 (37.0)

Table I - Material and Finish

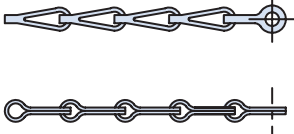
Code	Material	Finish Description
ME	Aluminum Alloy	Electroless Nickel
MT		Nickel-PTFE, Grey
NF		Cadmium, Olive Drab
ZR		Zinc-Nickel, Black
XM	Composite	Electroless Nickel
XW		Cadmium, Olive Drab
Z1	Stainless Steel	Passivate
ZL		Electro-Deposited Nickel

Table III: Lanyard Codes

Code	Description
D	Bead Chain, CRES, Passivated
H	Wire Rope, Teflon Jacket
N	No Lanyard
S	#8 Sash Chain, CRES, Passivated

SuperNine MT Fiber Optic Connectors



Metal and composite protective covers attachment options

Attaching a Cover to a Jam Nut Receptacle With a Solid Ring (Style A)

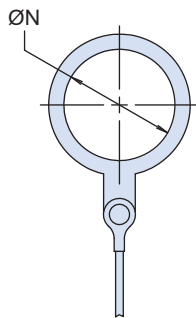
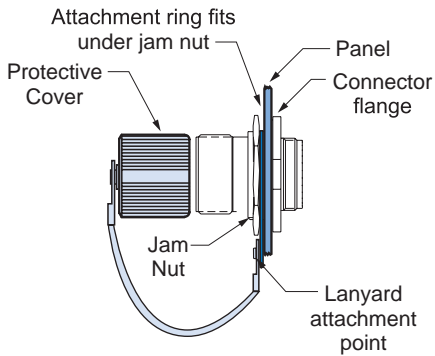

Solid Ring - Style A

Table IV: Solid Ring Style A

Dash No.	Ø N ± .015	183-001 Shell Size
106	.896 (22.8)	11
107	1.016 (25.9)	13
108	1.141 (29.0)	15
109	1.266 (32.3)	17

NOTES

Solid ring style A dash numbers and shell sizes shown are for Glenair 183-001 fiber optic connectors only. Consult factory for additional sizes.

Attaching a Cover to a Cable Assembly With a Solid Ring (Style B)

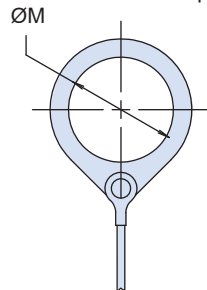
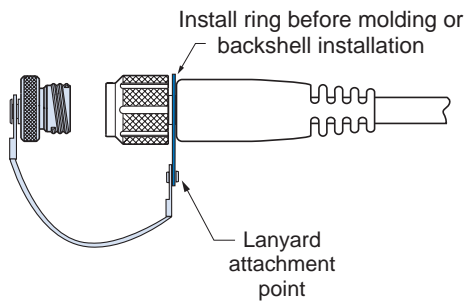

Solid Ring - Style B

Table V: Solid Ring Style B

Dash No.	Ø M ± .015	183-001 Shell Size
10	.593 (15.1)	11
12	.718 (18.2)	13
15	.890 (22.6)	15
17	1.015 (25.9)	17

NOTES

Solid ring style B dash numbers and shell sizes shown are for Glenair 183-001 fiber optic connectors only. Consult factory for additional sizes.

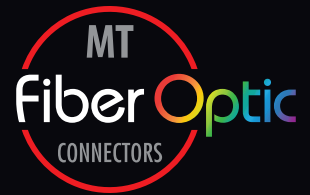

Attaching a Cover to a Cable Using a Split Ring or Slip Knot

Split Ring Style C

Slip Knot (Type SK)

Table VII: Split Ring Style C			
Dash No.	Ø L ± .015	Dash No.	Ø L ± .015
50	.425 (10.8)	74	1.625 (41.4)
52	.485 (12.3)	76	1.750 (44.5)
54	.640 (16.3)	78	1.875 (47.8)
56	.750 (19.1)	80	1.980 (50.3)
58	.890 (22.6)	82	2.060 (52.3)
60	1.015 (25.9)	84	2.235 (56.9)
62	1.095 (27.9)	86	2.310 (58.7)
64	1.130 (28.7)	88	2.475 (63.0)
66	1.250 (31.8)	90	2.655 (67.6)
68	1.350 (34.3)	92	2.810 (71.4)
70	1.375 (35.1)	94	3.045 (77.5)
72	1.485 (37.8)		

Attaching a Receptacle Cover to a Panel With a Screw

Eyelet - Style D

Table VI: Eyelet Style D when using connector mounting screw		
Dash No.	Ø K ± .015	183-001 Shell Size
06	.125 (3.18)	11 thru 17

HIGH-PERFORMANCE

FIBER OPTIC INTERCONNECT SYSTEMS



connectors · termini · cables · tools

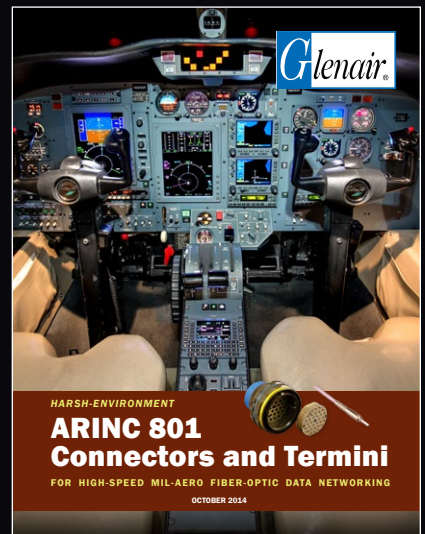
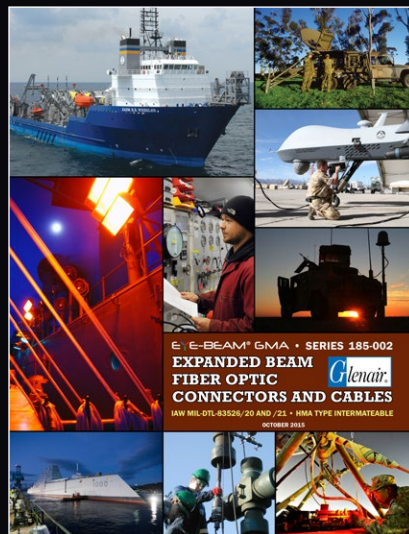
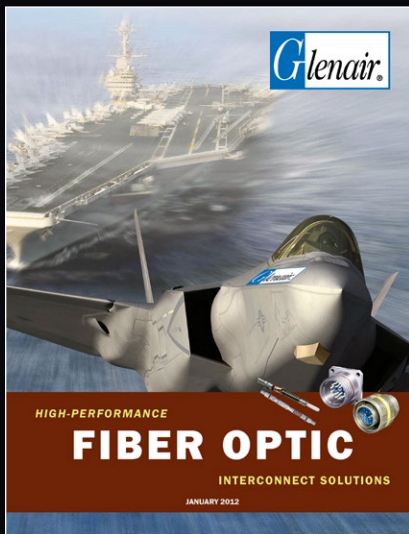

EYE-BEAM® GMA AND EYE-BEAM® GLT EXPANDED-BEAM CONNECTION SYSTEMS

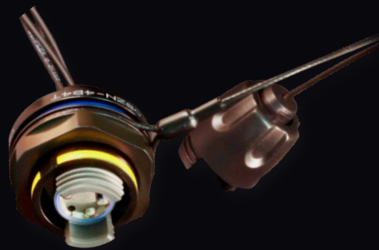

Eye-Beam® GMA (HMA type intermateable) IAW M83526/21 panel mount configuration



Eye-Beam® GMA (HMA type intermateable) IAW M83526/20 hermaphroditic cable plug configuration

Available cable reels and field-deployment technologies including man-packable units

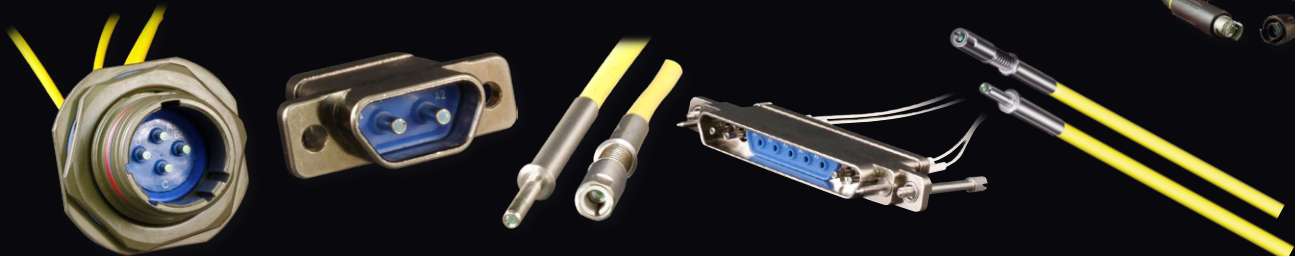

Innovative Eye-Beam® GLT grin-lens expanded-beam termini can be integrated into virtually any circular or rectangular connector package. Factory terminated lens pin termini and lens socket termini on cable jumpers allow for easy fusion splicing in the field.

GLENAIR BUTT-JOINT FIBER OPTIC CONNECTION SYSTEMS



MIL-DTL-38999 type fiber optic



Glenair High Density (GHD) fiber optic



Mighty Mouse fiber optic



ARINC 801 type fiber optic



Sr. 79, Micro-D, and other
MT Ferrule rectangulars



NGCON MIL-PRF-64266
fiber optics



Fiber optic Sav-Con®
connector savers



MIL-PRF-28876 Fiber Optic



GFOCA M83526 Compliant Fiber Optic



Glenair Front Release (GFR)
fiber optic

TOOL KITS AND TRAINING



Fiber Optic termination
and maintenance kits

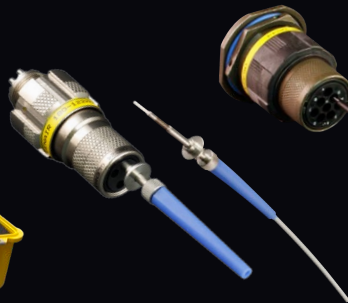

Fiber optic test probes
and adapters

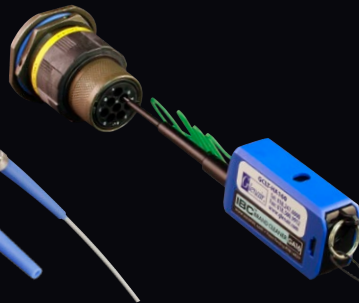

Dry-wipe fiber optic
cleaning tools



On-site fiber optic technician
certification training



FIBER OPTIC CONNECTOR BACKSHELLS



For user termination and fabrication of
fiber optic cable and conduit assemblies

TURNKEY FIBER OPTIC CABLE AND CONDUIT ASSEMBLIES



Catalog point-to-point solutions as well as
bespoke multibranch assemblies



MISSION-CRITICAL
INTERCONNECT
SOLUTIONS

Glenair, Inc.

1211 Air Way • Glendale, California • 91201-2497

Telephone: 818-247-6000 • Fax: 818-500-9912 • sales@glenair.com

www.glenair.com

**Glenair Power
Products Group**

20 Sterling Drive
Wallingford, CT
06492

Telephone:
203-741-1115
Facsimile:
203-741-0053
sales@glenair.com

Glenair UK Ltd

40 Lower Oakham Way
Oakham Business Park
Mansfield, Notts
NG18 5BY England

Telephone:
+44-1623-638100
Facsimile:
+44-1623-638111
sales@glenair.co.uk

Glenair Microway Systems

7000 North Lawndale Avenue
Lincolnwood, IL
60712

Telephone:
847-679-8833
Facsimile:
847-679-8849

Glenair Nordic AB

Gustav III : S Boulevard 42
SE-169 27 Solna
Sweden

Telephone:
+46-8-50550000
sales@glenair.se

Glenair GmbH

Schaberweg 28
61348 Bad Homburg
Germany

Telephone:
06172 / 68 16 0
Facsimile:
06172 / 68 16 90
info@glenair.de

Glenair Iberica

C/ La Vega, 16
45612 Velada
Spain

Telephone:
+34-925-89-29-88
Facsimile:
+34-925-89-29-87
sales@glenair.es

Glenair Italia S.p.A.

Via Del Lavoro, 7
40057 Quarto Inferiore –
Granarolo dell'Emilia
Bologna, Italy

Telephone:
+39-051-782811
Facsimile:
+39-051-782259
info@glenair.it

Glenair France SARL

7, Avenue Parmentier
Immeuble Central Parc #2
31200 Toulouse
France

Telephone:
+33-5-34-40-97-40
Facsimile:
+33-5-61-47-86-10
sales@glenair.fr

Glenair Korea

B-1304 Gunpo IT Valley
148 Gosan-Ro, Gunpo-Si
Kyunggi-Do, Korea
435-733

Telephone:
+82-31-8068-1090
Facsimile:
+82-31-8068-1092
sales@glenair.kr

© 2019 Glenair, Inc.

Printed in U.S.A.